



CLOUD GEHSHAN ASSOCIATES

Design Consultants

400 Market Street
Suite 300
Philadelphia, PA 19106

TEL 215 829 9414
FAX 215 829 9066
www.cloudgehshan.com



Western Michigan University

Campus Wayfinding - Signage Bid Set

WMU Project number LR10443

December 12, 2016

1	BASIC STANDARDS Artwork, color, and material specifications	1.1
2	DESIGN INTENT DRAWINGS: GATEWAYS Elevations and layouts	2.1
3	DESIGN INTENT DRAWINGS: SIGN SYSTEM Elevations and layouts	3.1
4	PERFORMANCE SPECIFICATIONS Sign performance, quality assurance and execution requirements	4.1
5	APPENDIX I Product specifications	5.1
6	SIGN LOCATIONS Sign removal plan and sign location plans	6.1
7	MESSAGE SCHEDULE Sign messages for all sign types	7.1

THIS DRAWING REPRESENTS DESIGN INTENT ONLY.
 FABRICATOR WILL BE RESPONSIBLE TO VERIFY ALL
 CONDITIONS IN FIELD PRIOR TO SHOP DRAWINGS.
 REFER TO SIGN LOCATION PLAN AND MESSAGE
 SCHEDULE FOR SIGN TYPES AND LOCATIONS.

Client/Project Western Michigan University Signage Bid Document		Project No. 14WMU249001
Date 12.12.16	Revisions	Scale As noted

Section 1 **Basic Standards**

Western Michigan University

L1 Selected wordmark for signage
Typeface: The Sans bold

Western Michigan University

L2 Two-line wordmark for signage
Typeface: The Sans bold

Western Michigan University

L3 Two-line wordmark for signage
Typeface: The Sans bold

THIS DRAWING REPRESENTS DESIGN INTENT ONLY.
FABRICATOR WILL BE RESPONSIBLE TO VERIFY ALL
CONDITIONS IN FIELD PRIOR TO SHOP DRAWINGS.
REFER TO SIGN LOCATION PLAN AND MESSAGE
SCHEDULE FOR SIGN TYPES AND LOCATIONS.

Client/Project		Project No.
Western Michigan University Signage Bid Document		14WMU249001
Date	Revisions	Scale
12.12.16		As noted

F1 Clearview 3-W

For vehicular signs on roads 30 mph or greater

ABCDEFGHIJKLMNOPQRSTUVWXYZ
abcdefghijklmnopqrstuvwxyz
1234567890 &!?,."

F2 The Sans Semibold Plain

For on-campus vehicular signs, pedestrian signs, and building identification signs

ABCDEFGHIJKLMNOPQRSTUVWXYZ
abcdefghijklmnopqrstuvwxyz
1234567890 &!?,."

F3 The Sans Bold Plain

For gateway signs and venue identification

ABCDEFGHIJKLMNOPQRSTUVWXYZ
abcdefghijklmnopqrstuvwxyz
1234567890 &!?,."

Typefaces

Typefaces

F1 - Clearview 3-W

F2 - The Sans Semibold Plain

F3 - The Sans Bold Plain

Notes

No substitute typefaces will be accepted.

Typefaces are available from:
Adobe Systems Inc. (www.adobe.com/type)
My Fonts (www.myfonts.com)

Adobe Illustrator character formatting

Adjusting kerning/tracking

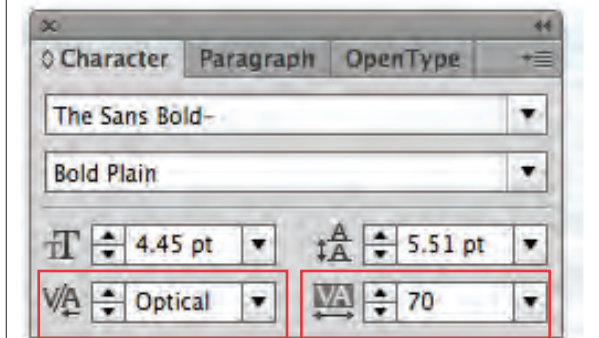

kerning control
set all to optical

tracking control
set as specified in layout

THIS DRAWING REPRESENTS DESIGN INTENT ONLY.
FABRICATOR WILL BE RESPONSIBLE TO VERIFY ALL
CONDITIONS IN FIELD PRIOR TO SHOP DRAWINGS.
REFER TO SIGN LOCATION PLAN AND MESSAGE
SCHEDULE FOR SIGN TYPES AND LOCATIONS.

Client/Project Western Michigan University Signage Bid Document		Project No. 14WMU249001
Date 12.12.16	Revisions	Scale As noted

BASIC STANDARDS

1.4

Typefaces

Typefaces

- F1 - Clearview 3-W
- F2 - The Sans Semibold Plain
- F3 - The Sans Bold Plain

Notes

No substitute typefaces will be accepted.
 Typefaces are available from:
 Adobe Systems Inc. (www.adobe.com/type)
 My Fonts (www.myfonts.com)

Adobe Illustrator character formatting

Adjusting kerning/tracking

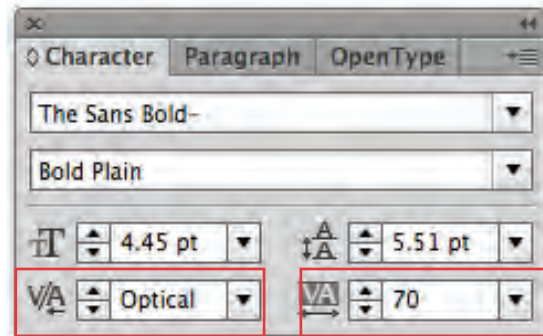

kerning control
set all to optical

tracking control
set as specified in layout

F4 The Sans Plain
For Plaza and
Recognition signs

ABCDEFGHIJKLMNOPQRSTUVWXYZ
 abcdefghijklmnopqrstuvwxyz
 1234567890 &!?,.”

F5 The Sans Plain Italic
For Plaza and
Recognition signs

ABCDEFGHIJKLMNOPQRSTUVWXYZ
abcdefghijklmnopqrstuvwxyz
1234567890 &!?,.”

THIS DRAWING REPRESENTS DESIGN INTENT ONLY.
 FABRICATOR WILL BE RESPONSIBLE TO VERIFY ALL
 CONDITIONS IN FIELD PRIOR TO SHOP DRAWINGS.
 REFER TO SIGN LOCATION PLAN AND MESSAGE
 SCHEDULE FOR SIGN TYPES AND LOCATIONS.

Client/Project Western Michigan University Signage Bid Document		Project No. 14WMU249001
Date 12.12.16	Revisions	Scale As noted

Artwork



A1 WMU "W"



A2 Parking



A3 Accessible symbol



A4 Historic Campus Icon

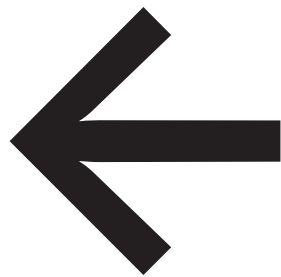

A4 Arrows

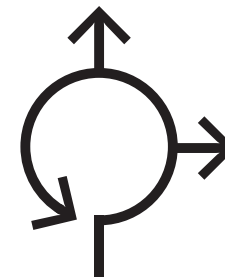
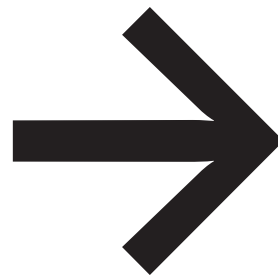
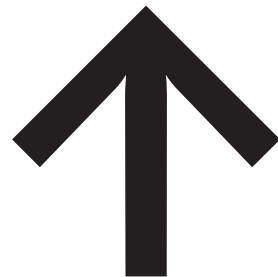

A5 Traffic circle - right exit

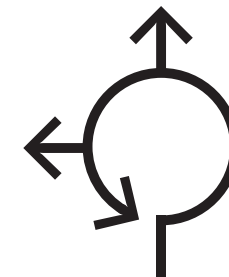

A6 Traffic circle - left exit

THIS DRAWING REPRESENTS DESIGN INTENT ONLY. FABRICATOR WILL BE RESPONSIBLE TO VERIFY ALL CONDITIONS IN FIELD PRIOR TO SHOP DRAWINGS. REFER TO SIGN LOCATION PLAN AND MESSAGE SCHEDULE FOR SIGN TYPES AND LOCATIONS.

Client/Project		Project No.
Western Michigan University Signage Bid Document		14WMU249001
Date	Revisions	Scale
12.12.16		As noted

Materials

BASIC STANDARDS

1.6

Materials

Aluminum

Oversized aluminum sheeting may be supplied by:

Pierce Aluminum Co Inc

995 Mearns Rd, Warminster, PA 18974
215-444-0884

Concrete

Stonecast Products, Inc.

Patrick Hoctor, Estimator/Project Manager
262-253-6600

Glass

Sheet glass supplied by:













Viracon, Inc.

Architectural Glass Fabrication
800-533-2080

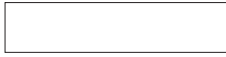
Curved glass elements supplied by:

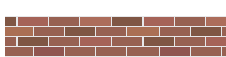
Bent Glass Design, Inc.

215-441-9101

Materials	Number	Color	Specification	Fabrication Process
	M1	Aluminum	Aluminum sheet painted with satin finish.	Sand blasted aluminum finish and coroflon clear coat
	M2	White 3930	Retro-reflective vinyl lettering applied to surface	3M High intensity prismatic sheeting
	M3	Pantone 355C	Retro-reflective vinyl applied to surface	3M High intensity prismatic sheeting
	M4	As specified in notes	Direct print to retro-reflective vinyl	CMYK exterior grade direct print to 3M high intensity prismatic sheeting
	M5	Custom WMU color	Precast concrete	Stonecast concrete
	M6	Varies	Direct print to vinyl and wrapped around 1/8" thick aluminum panel	CMYK exterior grade direct print
	M7	White	Push-through acrylic letter, illuminated	Router cut to shape
	M8	White	Corian dimensional letter	Router cut to shape
	M9	Aluminum	1/4" thick wall extruded square aluminum tube - painted	Aluminum extrusion
	M10	Brick	WMU Brick pattern (to be specified by client)	Masonry
	M11	Glass or 3form	Glass: Starfire Glass with 65% white PVB interlayer	TBD during prototyping phase
	M12	WMU Gold	3M Translucent Graphic film	3M Scotchcal film applied to surface
	M13	Matte White	Avery A9002-o	Applied vinyl





THIS DRAWING REPRESENTS DESIGN INTENT ONLY.
FABRICATOR WILL BE RESPONSIBLE TO VERIFY ALL
CONDITIONS IN FIELD PRIOR TO SHOP DRAWINGS.
REFER TO SIGN LOCATION PLAN AND MESSAGE
SCHEDULE FOR SIGN TYPES AND LOCATIONS.

Client/Project		Project No.
Western Michigan University Signage Bid Document		14WMU249001
Date	Revisions	Scale
12.12.16		As noted

Paints

1.7

BASIC STANDARDS

Paint Colors	Number	Color	Specification - color to match	Fabrication Process
	P1	Dark Brown - Panel	MP88706	Matthews Acrylic Polyurethane Paint, Satin Finish
	P2	Light Brown - Post	MP20156	Matthews Acrylic Polyurethane Paint, Satin Finish
	P3	Warm Silver - Band	MP20088 Grey Metallic P4	Matthews Acrylic Polyurethane Paint, Satin Finish
	P4	White	MP32071 White Wonder	Matthews Acrylic Polyurethane Paint, Satin Finish
	P5	Yellow	Pantone 124C	Matthews Acrylic Polyurethane Paint, Satin Finish

Paint

All painted components to be clear coated with Matthews 290-228SP Super Satin Clear Kit.

PPG Corafon paint products are specified for exterior signage and display hardware and related elements. No substitutions permitted.

Gloss finish of paint specified is to be 60 degrees or 29.8 on a 60 degree glossimeter. Refer to performance requirements for exact specifications.

PPG Architectural Coatings

1-800-774-4342

Matthews Paint

1-800-323-6593

Spraylat Corp.

1-800-767-2335

THIS DRAWING REPRESENTS DESIGN INTENT ONLY. FABRICATOR WILL BE RESPONSIBLE TO VERIFY ALL CONDITIONS IN FIELD PRIOR TO SHOP DRAWINGS. REFER TO SIGN LOCATION PLAN AND MESSAGE SCHEDULE FOR SIGN TYPES AND LOCATIONS.

Client/Project Western Michigan University Signage Bid Document		Project No. 14WMU249001
Date 12.12.16	Revisions	Scale As noted

Section 2 **Design Intent Drawings: Gateways**



THIS DRAWING REPRESENTS DESIGN INTENT ONLY.
 FABRICATOR WILL BE RESPONSIBLE TO VERIFY ALL
 CONDITIONS IN FIELD PRIOR TO SHOP DRAWINGS.
 REFER TO SIGN LOCATION PLAN AND MESSAGE
 SCHEDULE FOR SIGN TYPES AND LOCATIONS.

Client/Project		Project No.
Western Michigan University Signage Bid Document		14WMU249001
Date	Revisions	Scale
12.12.16		As noted



THIS DRAWING REPRESENTS DESIGN INTENT ONLY.
FABRICATOR WILL BE RESPONSIBLE TO VERIFY ALL
CONDITIONS IN FIELD PRIOR TO SHOP DRAWINGS.
REFER TO SIGN LOCATION PLAN AND MESSAGE
SCHEDULE FOR SIGN TYPES AND LOCATIONS.

Client/Project Western Michigan University Signage Bid Document		Project No. 14WMU249001
Date 12.12.16	Revisions	Scale As noted

Notes:
Sign face is to be single sheet with no seams or grommets.

Fabricator is responsible for waterproofing and water drainage details to avoid electrical problems or degradation.



2 GW 1 Sign layout
scale: 1/4" = 1'-0"

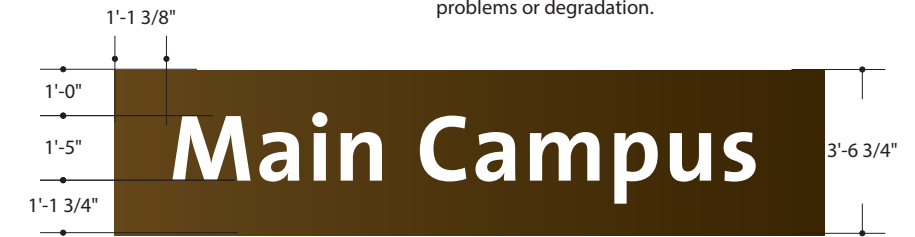

3 GW 2 Sign layout
scale: 1/4" = 1'-0"

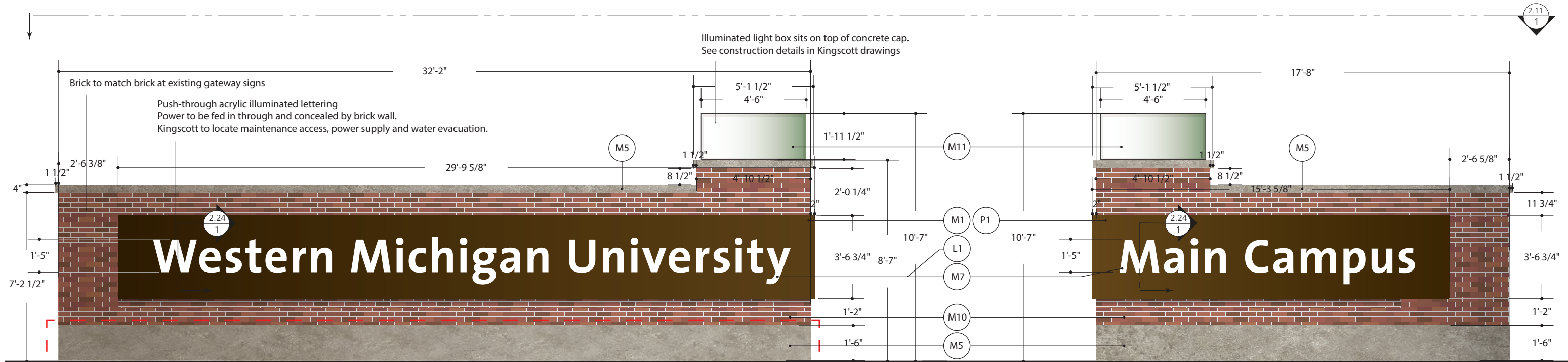

1 GW 1 elevation
scale: 1/4" = 1'-0"

see grading and base detail on page 2.12 and in Kingscott drawings

4 GW 2 elevation
scale: 1/4" = 1'-0"

THIS DRAWING REPRESENTS DESIGN INTENT ONLY.
FABRICATOR WILL BE RESPONSIBLE TO VERIFY ALL
CONDITIONS IN FIELD PRIOR TO SHOP DRAWINGS.
REFER TO SIGN LOCATION PLAN AND MESSAGE
SCHEDULE FOR SIGN TYPES AND LOCATIONS.

Client/Project Western Michigan University Signage Bid Document		Project No. 14WMU249001
Date 12.12.16	Revisions	Scale As noted

Note:
See Kingscott drawings for lighting,
attachment and access panel details

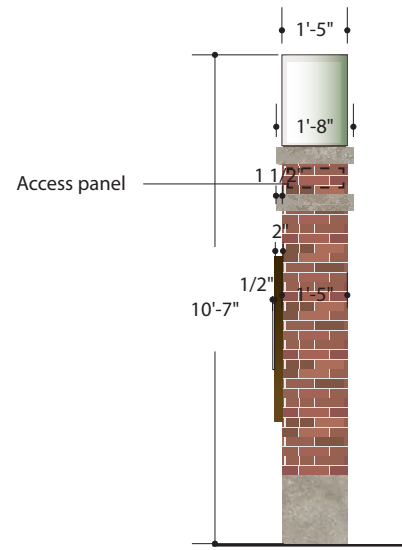

2 Side view - GW 2
scale: 1/4" = 1'-0"

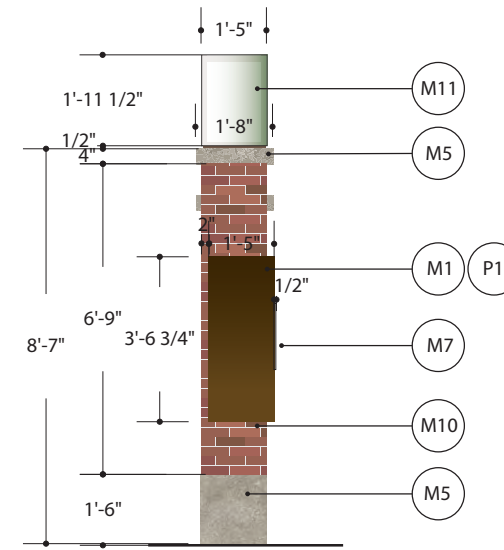

3 Side view - GW 2
scale: 1/4" = 1'-0"

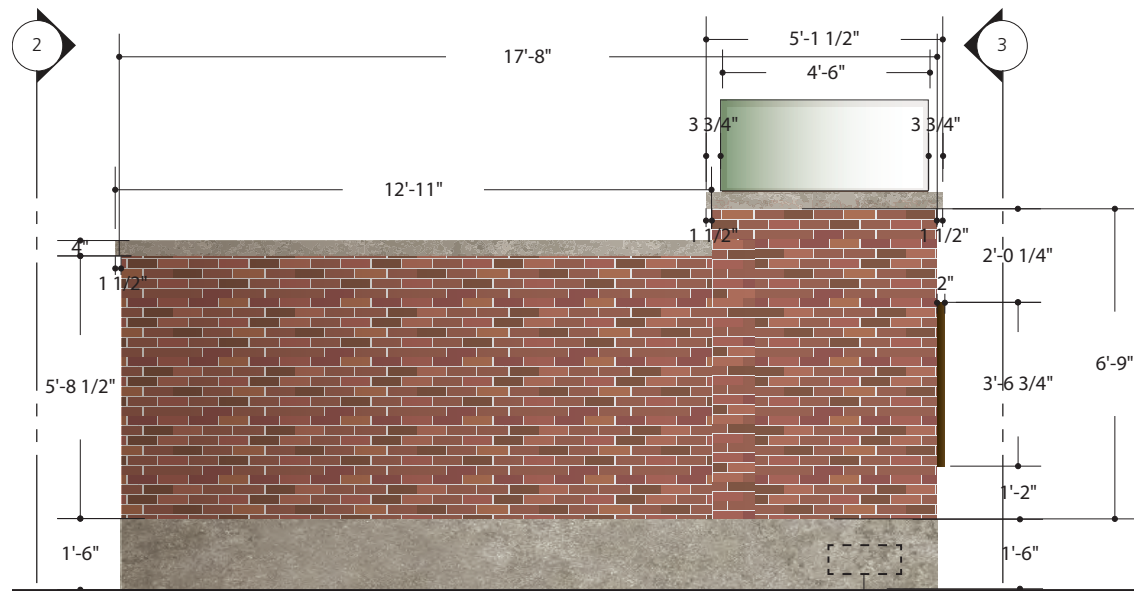

1 GW2 elevation - back view
scale: 1/4" = 1'-0"

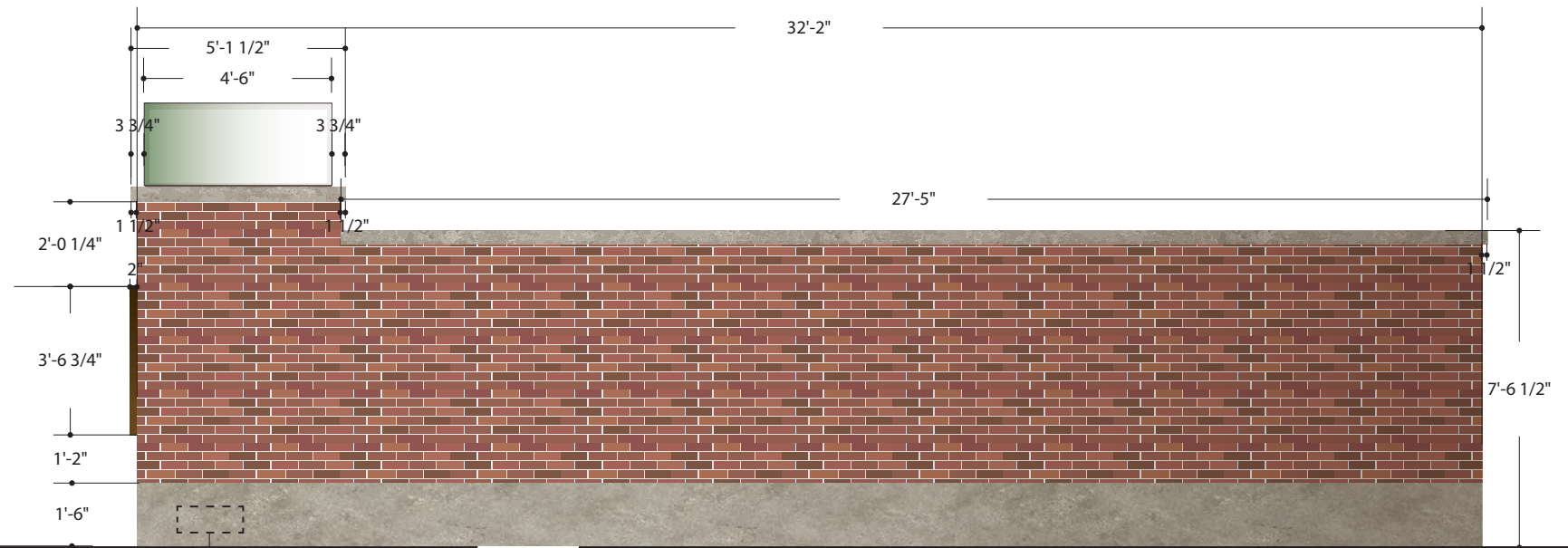

4 GW1 elevation - back view
scale: 1/4" = 1'-0"

Client/Project		Project No.
Western Michigan University Signage Bid Document		14WMU249001
Date	Revisions	Scale
12.12.16		As noted

THIS DRAWING REPRESENTS DESIGN INTENT ONLY.
FABRICATOR WILL BE RESPONSIBLE TO VERIFY ALL
CONDITIONS IN FIELD PRIOR TO SHOP DRAWINGS.
REFER TO SIGN LOCATION PLAN AND MESSAGE
SCHEDULE FOR SIGN TYPES AND LOCATIONS.

Oliver Gateway - Plan views

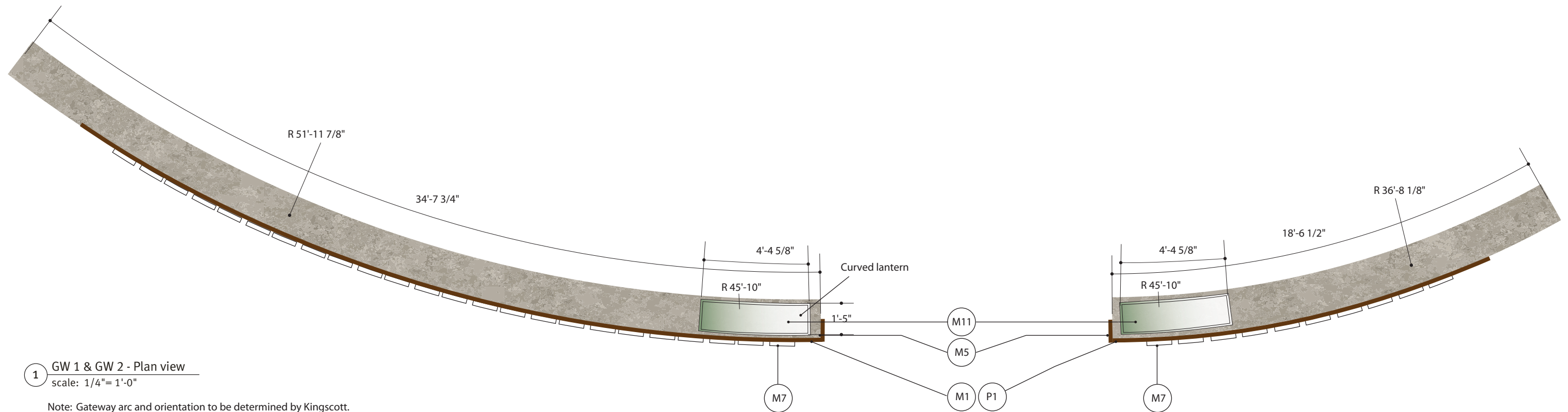

1 GW 1 & GW 2 - Plan view
scale: 1/4" = 1'-0"

Note: Gateway arc and orientation to be determined by Kingscott.
See Appendix I for details

THIS DRAWING REPRESENTS DESIGN INTENT ONLY.
FABRICATOR WILL BE RESPONSIBLE TO VERIFY ALL
CONDITIONS IN FIELD PRIOR TO SHOP DRAWINGS.
REFER TO SIGN LOCATION PLAN AND MESSAGE
SCHEDULE FOR SIGN TYPES AND LOCATIONS.

Client/Project		Project No.
Western Michigan University Signage Bid Document		14WMU249001
Date	Revisions	Scale
12.12.16		As noted

Oliver Gateway - Landscape/base detail

DRAWINGS

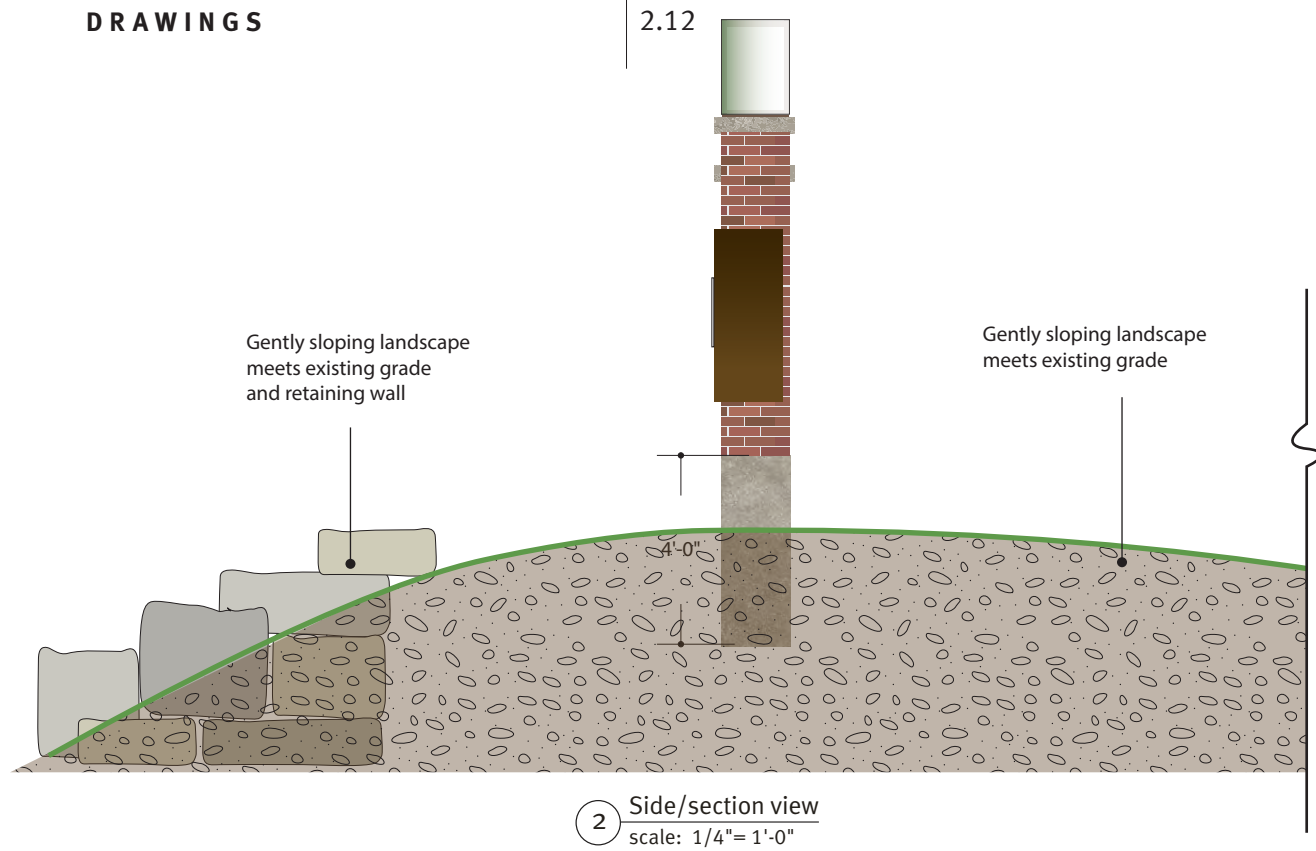

3 In situ
scale: NTS

Gently sloping landscape meets existing grade
See additional landscape details in Kingscott drawings



1 GW 1 elevation
scale: 1/4"= 1'-0"

Client/Project		Project No.
Western Michigan University Signage Bid Document		14WMU249001
Date	Revisions	Scale
12.12.16		As noted

THIS DRAWING REPRESENTS DESIGN INTENT ONLY.
FABRICATOR WILL BE RESPONSIBLE TO VERIFY ALL
CONDITIONS IN FIELD PRIOR TO SHOP DRAWINGS.
REFER TO SIGN LOCATION PLAN AND MESSAGE
SCHEDULE FOR SIGN TYPES AND LOCATIONS.

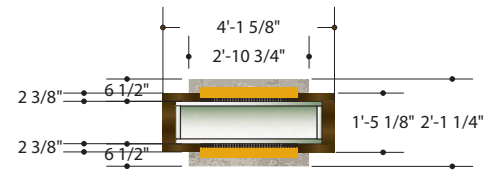

2 Plan view
scale: 1/4" = 1'-0"

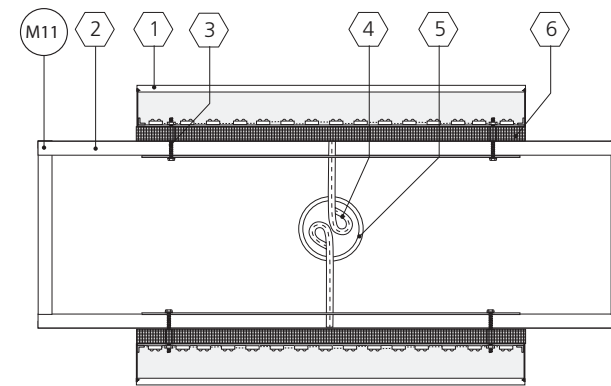

4 Section view
scale: 1" = 1'-0"

- 1 Fabricated .080 aluminum channel letters, see page 2.14 for details
- 2 Frameless glass panels; attachments and engineering by Kingscott. See Kingscott drawings for details.
- 3 Letter is face-mounted to glass; mechanically fastened from inside
- 4 Low voltage wire connects to a rheostat to allow light intensity adjustments. Connect to a remote transformer placed in an accessible area, VIF.
- 5 Center round extruded post houses wiring to base. Wrapped with reflective covering to prevent shadowing in box
- 6 1" wide insect screen

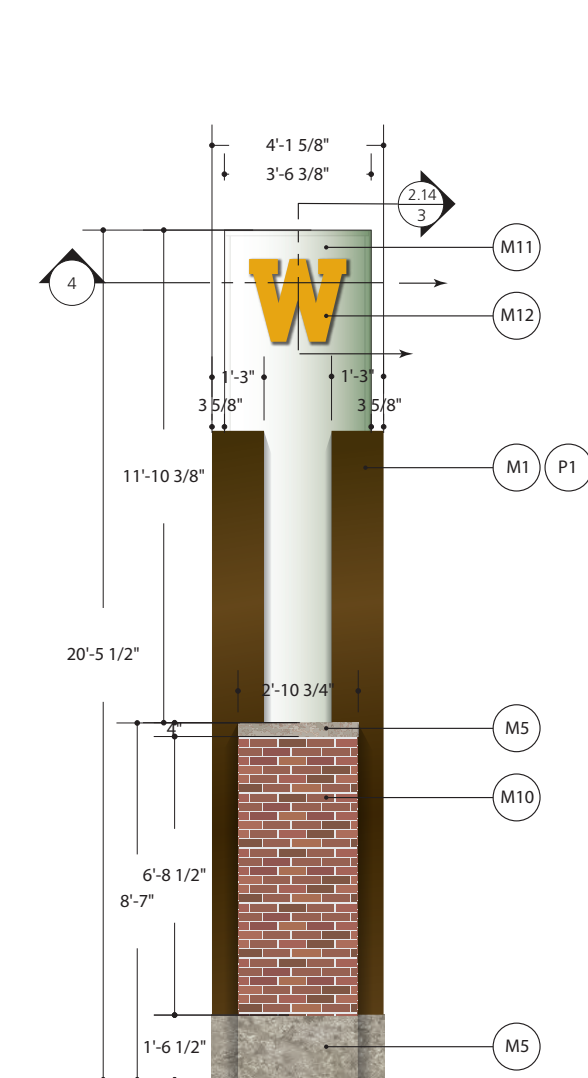

1 Elevation - GW 3
scale: 1/4" = 1'-0"

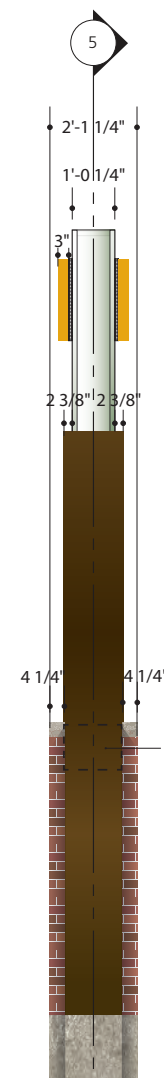

3 Side view - GW 3
scale: 1/4" = 1'-0"

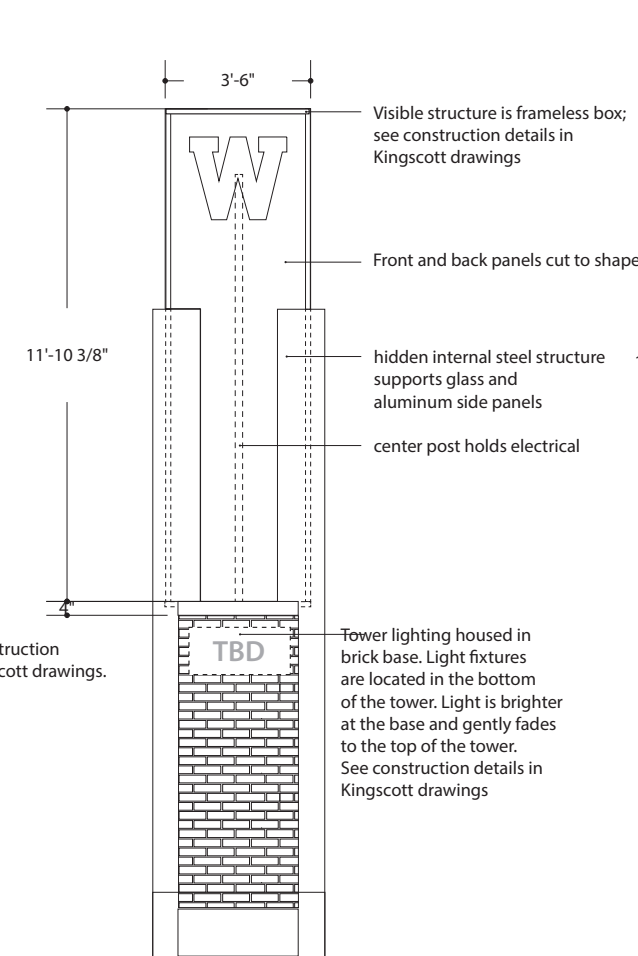

5 Section view - internal structure
scale: 1/4" = 1'-0"

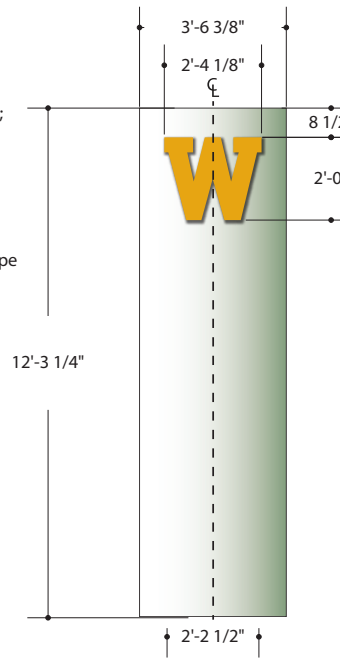

6 Glass panels
scale: 1/4" = 1'-0"

THIS DRAWING REPRESENTS DESIGN INTENT ONLY. FABRICATOR WILL BE RESPONSIBLE TO VERIFY ALL CONDITIONS IN FIELD PRIOR TO SHOP DRAWINGS. REFER TO SIGN LOCATION PLAN AND MESSAGE SCHEDULE FOR SIGN TYPES AND LOCATIONS.

Client/Project Western Michigan University Signage Bid Document		Project No. 14WMU249001
Date 12.12.16	Revisions	Scale As noted

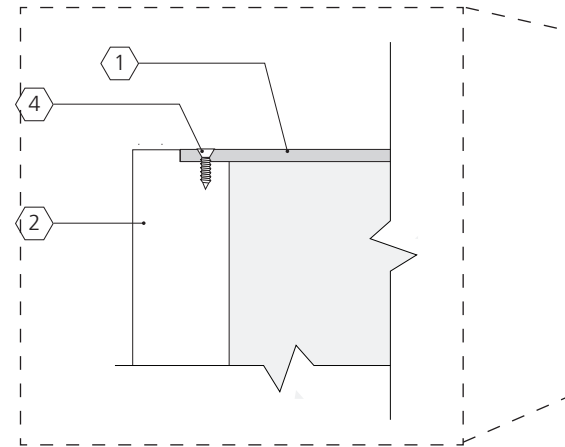

2 Section - Typical Retainer Edge Detail
scale: full scale

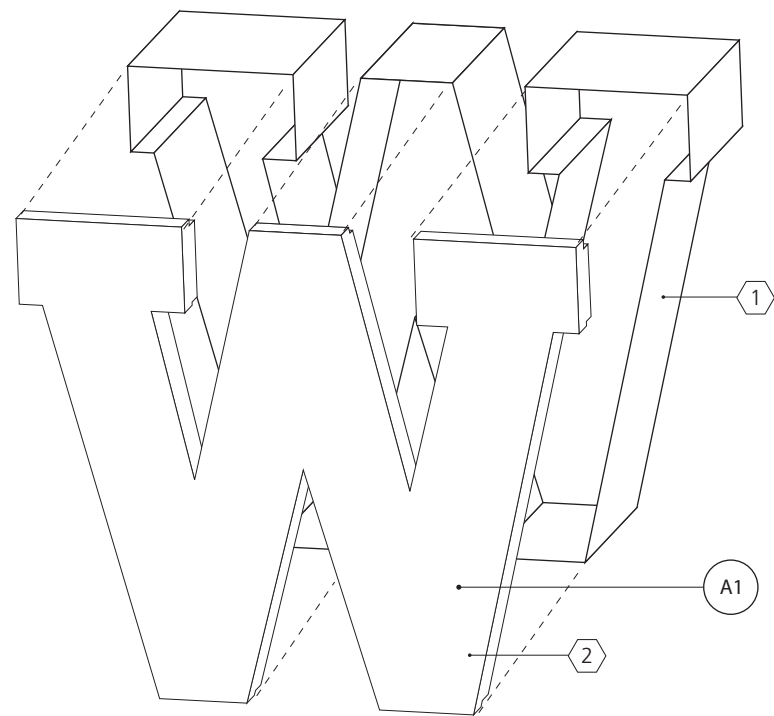

1 Perspective View
scale: n. t. s.

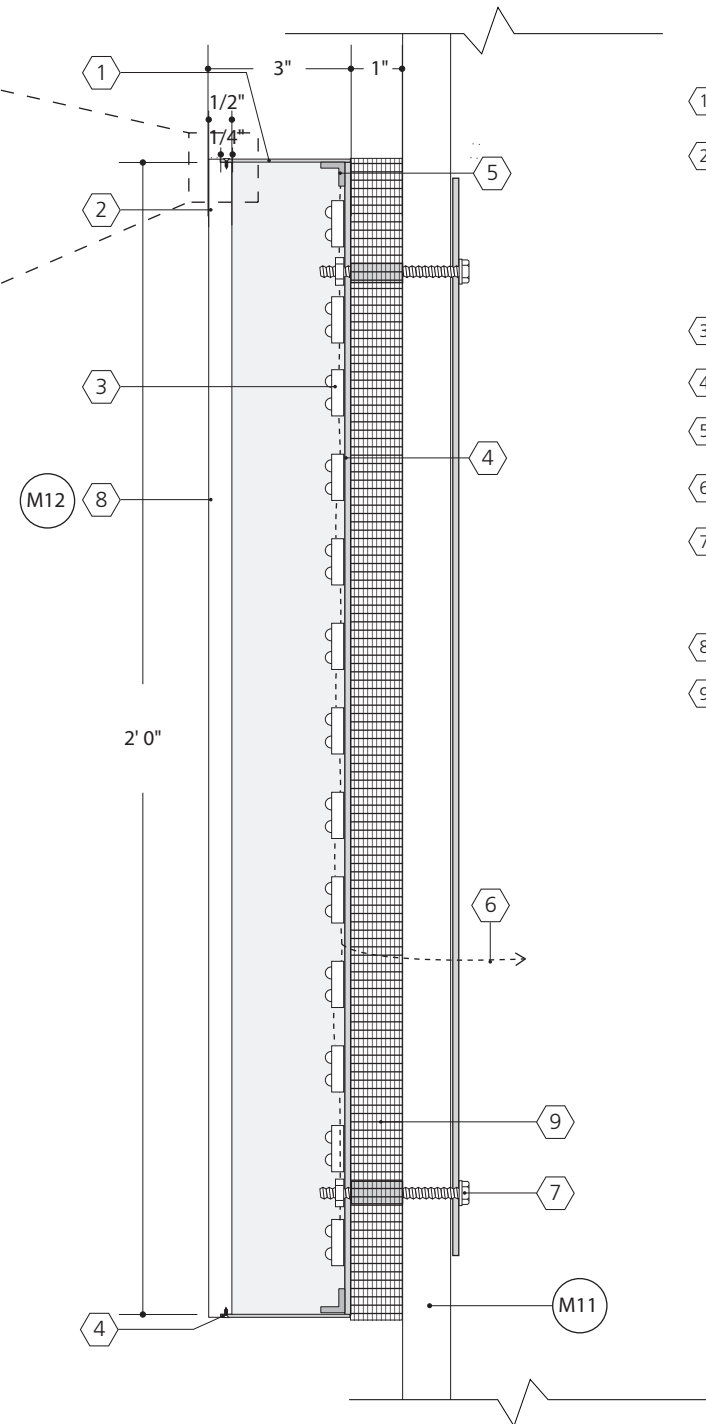

3 Section - Typical Detail
scale: 3"=1'-0"

- ① Fabricated .080 aluminum channel letters, painted (P5)
- ② 1/2" thick router-cut lexan/acrylic with diffuser film applied to the back side. Routed 1/4" lip is received by aluminum channel and secured at top and bottom by tamper-resistant, countersunk fasteners. Top and bottom edges of acrylic painted (P5) to match aluminum channel
- ③ White LED module mounted to back of letter
- ④ Tamper-resistant, countersunk fasteners
- ⑤ Internal aluminum angle framing
- ⑥ Low voltage wire to remote transformer
- ⑦ Letter is mechanically fastened through glass to aluminum plate. Plate is secured to internal structure.
- ⑧ 3M Translucent graphic film applied to surface.
- ⑨ 1" wide insect screen

Notes:
Fabricator is responsible for waterproofing and water drainage details to avoid electrical problems or degradation.

Minimum 15-year warranty on LEDs is required.

THIS DRAWING REPRESENTS DESIGN INTENT ONLY. FABRICATOR WILL BE RESPONSIBLE TO VERIFY ALL CONDITIONS IN FIELD PRIOR TO SHOP DRAWINGS. REFER TO SIGN LOCATION PLAN AND MESSAGE SCHEDULE FOR SIGN TYPES AND LOCATIONS.

Client/Project		Project No.
Western Michigan University Signage Bid Document		14WMU249001
Date	Revisions	Scale
12.12.16		As noted

Retrofit gateways



HOWARD ST & W MICHIGAN AVE (NORTH SIDE)
GW 4 - use Main Campus layout page 2.22



HOWARD ST & W MICHIGAN AVE (SOUTH SIDE)
GW 4 - use Main Campus layout page 2.22



OAKLAND DR & STADIUM DR
GW 4 - use East Campus layout page 2.23



OAKLAND DR & HOWARD ST
GW 4 - use East Campus layout page 2.23



STADIUM DR & HOWARD ST
GW 4 - use Main Campus layout page 2.22



OLIVER ST & STADIUM DR
GW 4 - use East Campus layout page 2.23



OAKLAND DR & OLIVER ST
GW 5 - use custom size/layout page 2.24

Notes:
Due to variations in existing structures, all retrofit signs require thorough field survey by the fabricator. Templates may be required to ensure accurate fit.

Fabricator is responsible for the removal of Bronze Medallion and lettering. Visible holes must be patched and filled with ground brick shavings to match existing brick.

Existing floodlights to remain. Contractor to repair/replace existing landscape planting damaged by construction work.

THIS DRAWING REPRESENTS DESIGN INTENT ONLY.
FABRICATOR WILL BE RESPONSIBLE TO VERIFY ALL CONDITIONS IN FIELD PRIOR TO SHOP DRAWINGS.
REFER TO SIGN LOCATION PLAN AND MESSAGE SCHEDULE FOR SIGN TYPES AND LOCATIONS.

Client/Project Western Michigan University Signage Bid Document		Project No. 14WMU249001
Date 12.12.16	Revisions	Scale As noted

Howard and West Michigan Avenue - Retrofit gateway and add Tower



THIS DRAWING REPRESENTS DESIGN INTENT ONLY.
FABRICATOR WILL BE RESPONSIBLE TO VERIFY ALL
CONDITIONS IN FIELD PRIOR TO SHOP DRAWINGS.
REFER TO SIGN LOCATION PLAN AND MESSAGE
SCHEDULE FOR SIGN TYPES AND LOCATIONS.

Client/Project		Project No.
Western Michigan University Signage Bid Document		14WMU249001
Date	Revisions	Scale
12.12.16		As noted



THIS DRAWING REPRESENTS DESIGN INTENT ONLY. FABRICATOR WILL BE RESPONSIBLE TO VERIFY ALL CONDITIONS IN FIELD PRIOR TO SHOP DRAWINGS. REFER TO SIGN LOCATION PLAN AND MESSAGE SCHEDULE FOR SIGN TYPES AND LOCATIONS.

Client/Project Western Michigan University Signage Bid Document		Project No. 14WMU249001
Date 12.12.16	Revisions	Scale As noted

Retrofit gateways

DRAWINGS

2.20

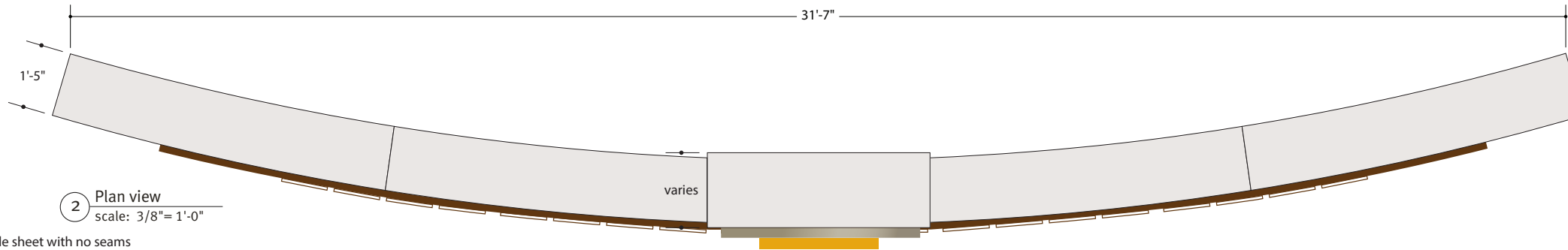

2 Plan view
scale: 3/8" = 1'-0"

Notes:
Sign face is to be single sheet with no seams or grommets.

Fabricator is responsible for waterproofing and water drainage details to avoid electrical problems or degradation.

Fabricator to design maintenance access to sign boxes.

Due to variations in existing structures, all retrofit signs require thorough field survey by the fabricator. Templates may be required to ensure accurate fit.

For additional construction details, see Kingscott drawings.



1 Elevation - Retrofit - GW04
scale: 3/8" = 1'-0"

2 Side view - GW04
scale: 3/8" = 1'-0"

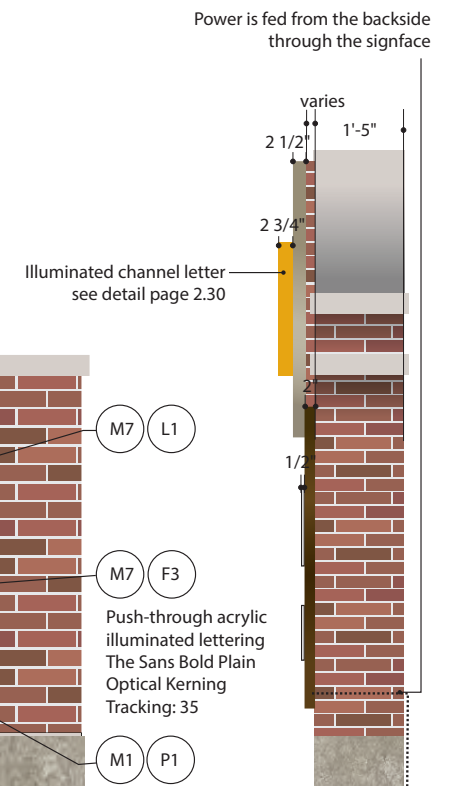

Client/Project		Project No.
Western Michigan University Signage Bid Document		14WMU249001
Date	Revisions	Scale
12.12.16		As noted

THIS DRAWING REPRESENTS DESIGN INTENT ONLY.
FABRICATOR WILL BE RESPONSIBLE TO VERIFY ALL
CONDITIONS IN FIELD PRIOR TO SHOP DRAWINGS.
REFER TO SIGN LOCATION PLAN AND MESSAGE
SCHEDULE FOR SIGN TYPES AND LOCATIONS.

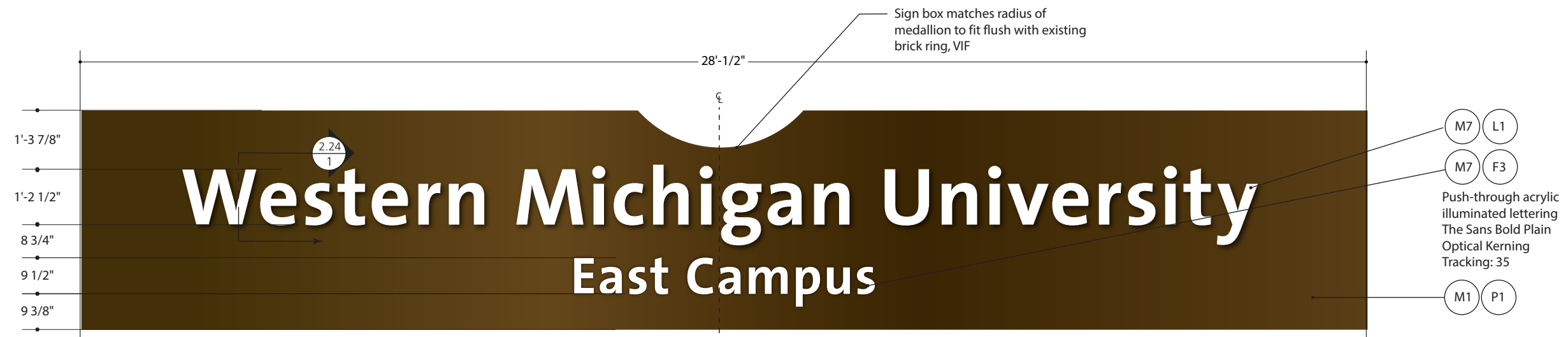

1 Elevation – Retrofit - GW04 - East Campus Layout
scale: 3/8" = 1'-0"

Notes:
Sign face is to be single sheet with no seams or grommets.

Fabricator is responsible for waterproofing and water drainage details to avoid electrical problems or degradation.

Fabricator to design maintenance access to sign boxes.

Due to variations in existing structures, all retrofit signs require thorough field survey by the fabricator. Templates may be required to ensure accurate fit.

- M7 L1
 - M7 F3
 - M1 P1
- Push-through acrylic illuminated lettering
The Sans Bold Plain
Optical Kerning
Tracking: 35

THIS DRAWING REPRESENTS DESIGN INTENT ONLY. FABRICATOR WILL BE RESPONSIBLE TO VERIFY ALL CONDITIONS IN FIELD PRIOR TO SHOP DRAWINGS. REFER TO SIGN LOCATION PLAN AND MESSAGE SCHEDULE FOR SIGN TYPES AND LOCATIONS.

Client/Project Western Michigan University Signage Bid Document		Project No. 14WMU249001
Date 12.12.16	Revisions	Scale As noted

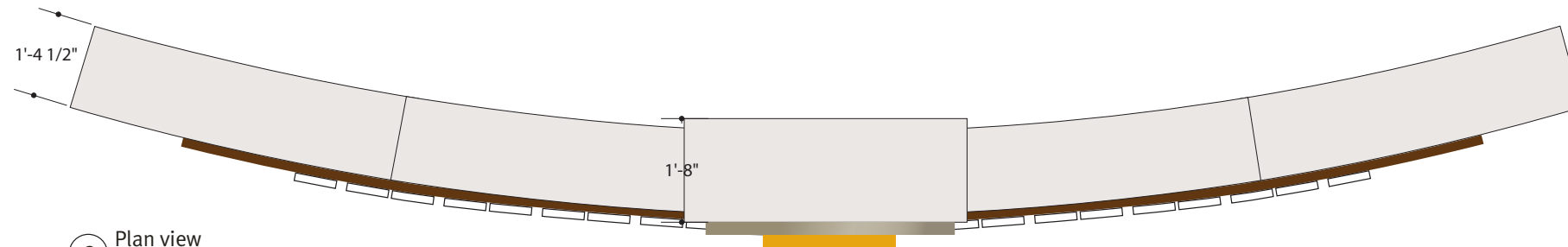

2 Plan view
scale: 3/8" = 1'-0"

Notes:
Sign face is to be single sheet with no seams or grommets.

Fabricator is responsible for waterproofing and water drainage details to avoid electrical problems or degradation.

Fabricator to design maintenance access to sign boxes.

Due to variations in existing structures, all retrofit signs require thorough field survey by the fabricator. Templates may be required to ensure accurate fit.

For additional construction details, see Kingscott drawings.



1 Elevation – Retrofit – GW05 - Oliver and Oakland Dr
scale: 3/8" = 1'-0"

2 Side view
scale: 3/8" = 1'-0"

THIS DRAWING REPRESENTS DESIGN INTENT ONLY.
FABRICATOR WILL BE RESPONSIBLE TO VERIFY ALL CONDITIONS IN FIELD PRIOR TO SHOP DRAWINGS.
REFER TO SIGN LOCATION PLAN AND MESSAGE SCHEDULE FOR SIGN TYPES AND LOCATIONS.

Client/Project		Project No.
Western Michigan University Signage Bid Document		14WMU249001
Date	Revisions	Scale
12.12.16		As noted

Channel letter detail

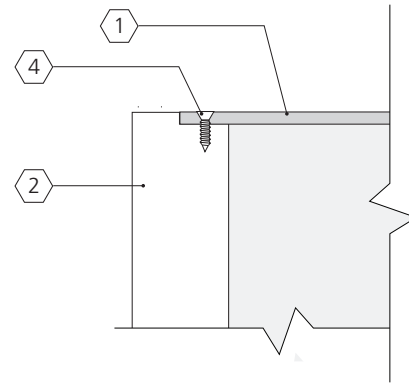

2 Section - Typical Retainer Edge Detail
scale: full scale

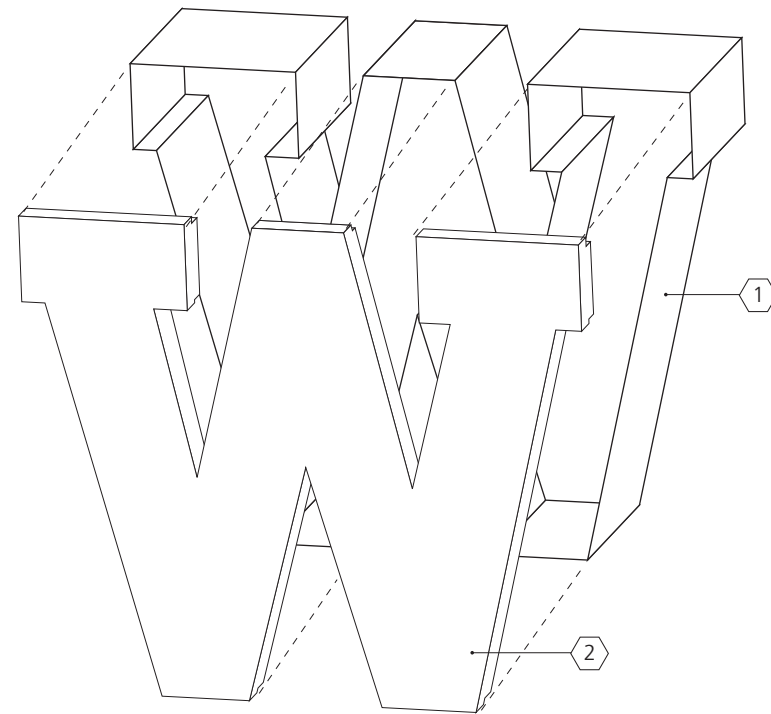

1 Perspective View
scale: n. t. s.

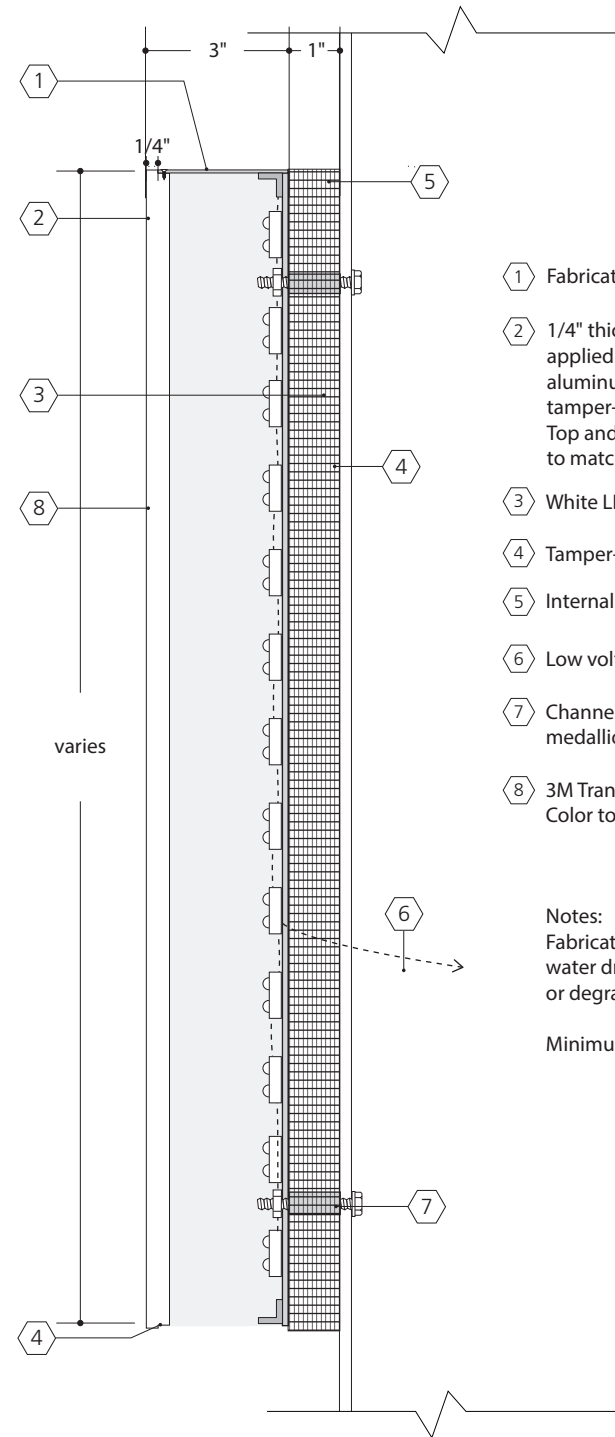

3 Section - Typical Detail
scale: 3" = 1'-0"

- 1 Fabricated .080 aluminum channel letters, painted (P5)
- 2 1/4" thick router-cut lexan/acrylic with diffuser film applied to the back side. Routed 1/8" lip is received by aluminum channel and secured at top and bottom by tamper-resistant, countersunk fasteners. Top and bottom edges of acrylic painted (P5) to match aluminum channel
- 3 White LED module mounted to back of letter
- 4 Tamper-resistant, countersunk fasteners
- 5 Internal aluminum angle framing
- 6 Low voltage wire to remote transformer
- 7 Channel letter is mechanically fastened to medallion
- 8 3M Translucent graphic film applied to surface. Color to match Pantone 131C.

Notes:
Fabricator is responsible for waterproofing and water drainage details to avoid electrical problems or degradation.

Minimum 15-year warranty on LEDs is required.

THIS DRAWING REPRESENTS DESIGN INTENT ONLY. FABRICATOR WILL BE RESPONSIBLE TO VERIFY ALL CONDITIONS IN FIELD PRIOR TO SHOP DRAWINGS. REFER TO SIGN LOCATION PLAN AND MESSAGE SCHEDULE FOR SIGN TYPES AND LOCATIONS.

Client/Project Western Michigan University Signage Bid Document		Project No. 14WMU249001
Date 12.12.16	Revisions	Scale As noted

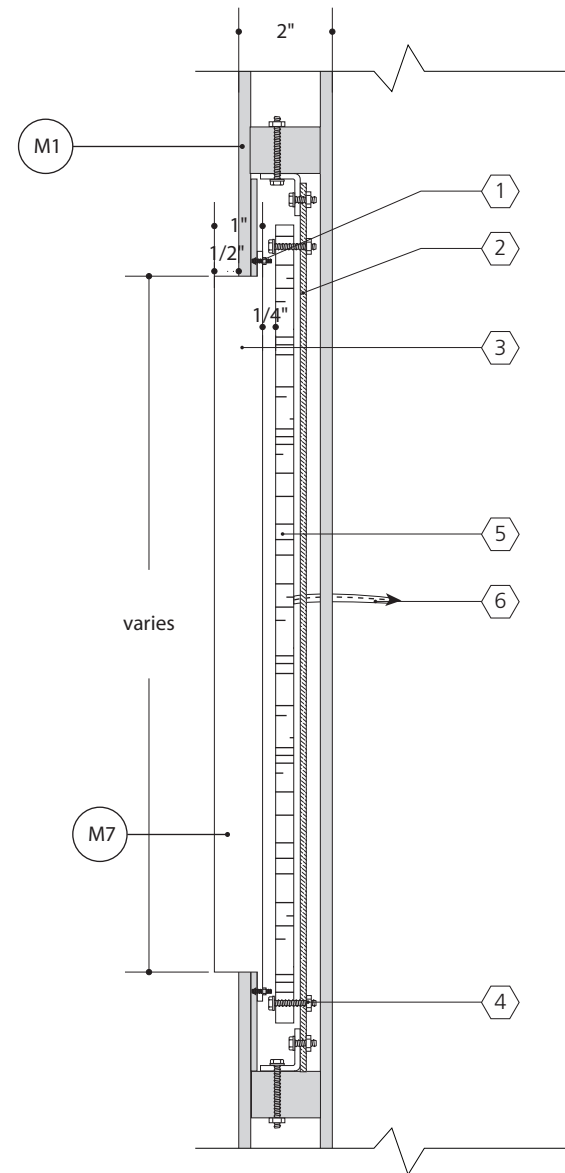

- ① Threaded stud is fillet welded to the interior side of cabinet, nut secures acrylic to aluminum.
- ② 1/8" thick aluminum plate; mechanically fastened to internal structure.
- ③ 1" thick router-cut acrylic with routed-out flange and white diffuser film applied to back side.
- ④ DLC Lumisheet is mechanically fastened to aluminum mounting plate.
- ⑤ DLC Lumisheet LED Light Panel connected to approved 60 watt, 12 volt DC exterior rated power supply. Reference page 5.4 for LED and power supply details. Provide details for dimming capabilities. Power supply with a 10 year warranty is recommended, fabricator to provide details for review prior to installation.
- ⑥ Low voltage wire to remote transformer.

① Typical section detail - Push-through acrylic lettering
scale: 3" = 1'-0"

THIS DRAWING REPRESENTS DESIGN INTENT ONLY. FABRICATOR WILL BE RESPONSIBLE TO VERIFY ALL CONDITIONS IN FIELD PRIOR TO SHOP DRAWINGS. REFER TO SIGN LOCATION PLAN AND MESSAGE SCHEDULE FOR SIGN TYPES AND LOCATIONS.

Client/Project		Project No.
Western Michigan University Signage Bid Document		14WMU249001
Date	Revisions	Scale
12.12.16		As noted

Medallion detail



1 Elevation –Gateway medallion, typical
scale: 1 1/2"= 1'-0"

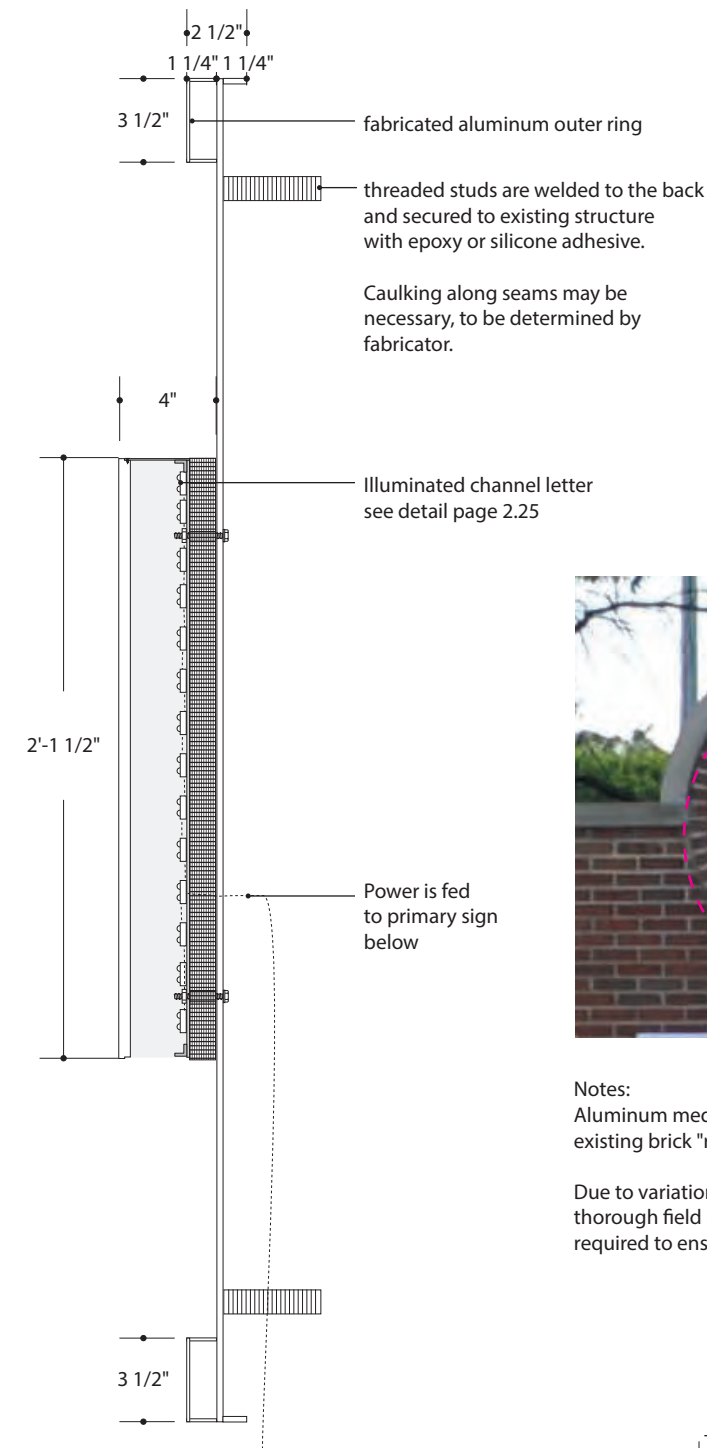

2 Section view
scale: 1 1/2"= 1'-0"



Notes:
Aluminum medallion to be sized to completely cover the existing brick "ring."

Due to variations in existing structures, all retrofit signs require thorough field survey by the fabricator. Templates may be required to ensure accurate fit.

THIS DRAWING REPRESENTS DESIGN INTENT ONLY. FABRICATOR WILL BE RESPONSIBLE TO VERIFY ALL CONDITIONS IN FIELD PRIOR TO SHOP DRAWINGS. REFER TO SIGN LOCATION PLAN AND MESSAGE SCHEDULE FOR SIGN TYPES AND LOCATIONS.

Client/Project Western Michigan University Signage Bid Document		Project No. 14WMU249001
Date 12.12.16	Revisions	Scale As noted



THIS DRAWING REPRESENTS DESIGN INTENT ONLY. FABRICATOR WILL BE RESPONSIBLE TO VERIFY ALL CONDITIONS IN FIELD PRIOR TO SHOP DRAWINGS. REFER TO SIGN LOCATION PLAN AND MESSAGE SCHEDULE FOR SIGN TYPES AND LOCATIONS.

Client/Project Western Michigan University Signage Bid Document		Project No. 14WMU249001
Date 12.12.16	Revisions	Scale As noted

ST 30 - Venue ID - Double-faced

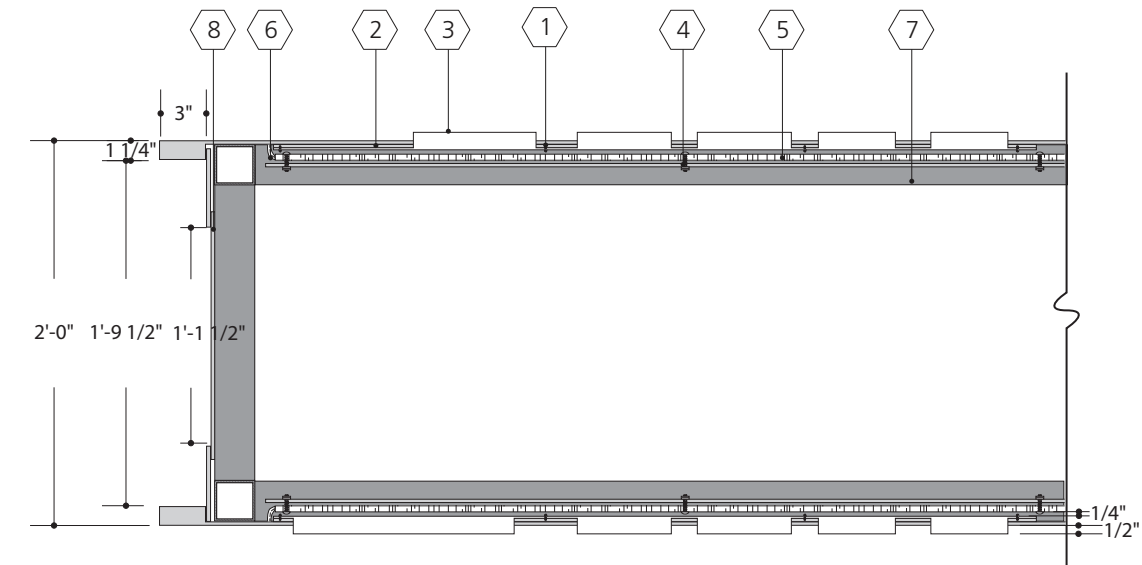

- 1 Threaded stud is fillet welded to the interior side of cabinet, nut secures acrylic to aluminum.
- 2 1/8" thick aluminum plate with welded stud attachment; mechanically fastened to internal structure.
- 3 1" thick router-cut acrylic with routed-out flange and white diffuser film applied to back side.
- 4 DLC Lumisheet is mechanically fastened to aluminum mounting plate.
- 5 DLC Lumisheet LED Light Panel connected to approved 60 watt, 12 volt DC exterior rated power supply. Reference page 5.4 for LED and power supply details. Provide details for dimming capabilities. Power supply with a 10 year warranty is recommended, fabricator to provide details for review prior to installation.
- 6 Low voltage wire to remote transformer.
- 7 Steel frame with face panel attached.
- 8 1/4" thick aluminum perforated panel, 1/8" Holes on 3/16" Centers, Staggered Pattern, is welded to aluminum side panels.
- 9 4" thick precast concrete cladding, seams on sides. Base to be engineered by the fabricator.

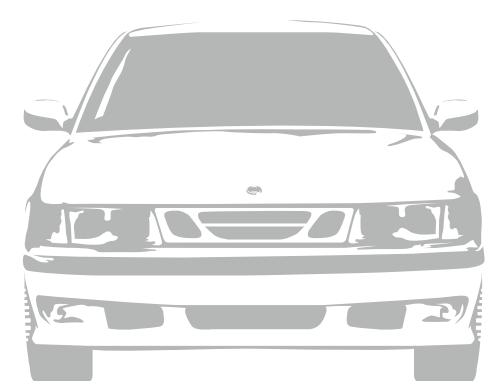

THIS DRAWING REPRESENTS DESIGN INTENT ONLY.
FABRICATOR WILL BE RESPONSIBLE TO VERIFY ALL
CONDITIONS IN FIELD PRIOR TO SHOP DRAWINGS

Client/Project Western Michigan University Signage Bid Document		Project No. 14WMU249001
Date 12.12.16	Revisions	Scale As noted

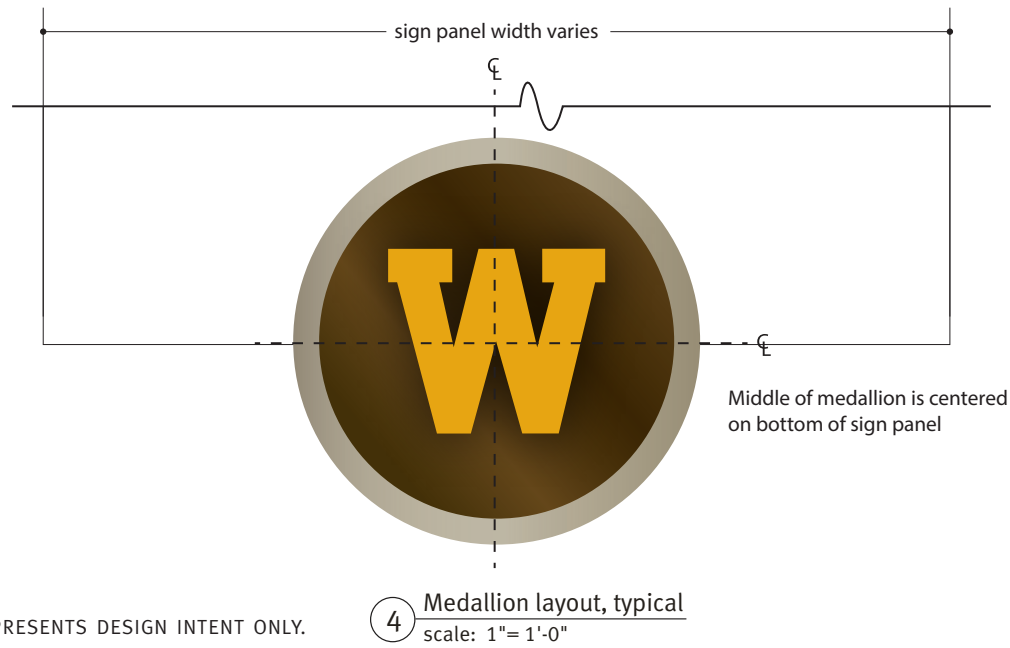
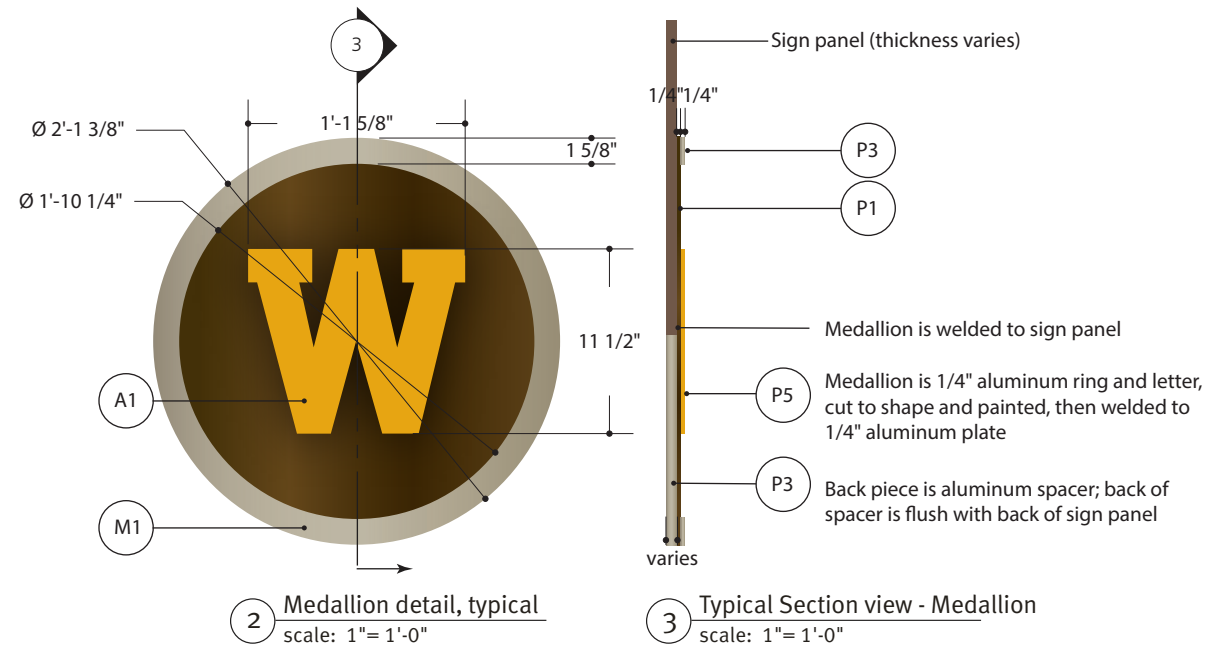

THIS DRAWING REPRESENTS DESIGN INTENT ONLY. FABRICATOR WILL BE RESPONSIBLE TO VERIFY ALL CONDITIONS IN FIELD PRIOR TO SHOP DRAWINGS. REFER TO SIGN LOCATION PLAN AND MESSAGE SCHEDULE FOR SIGN TYPES AND LOCATIONS.

Client/Project Western Michigan University Signage Bid Document		Project No. 14WMU249001
Date 12.12.16	Revisions	Scale As noted



F3
The Sans Bold Plain
Optical Kerning
Tracking: 35

Digital content layout TBD



GWo6 sign located at the base of the hill



THIS DRAWING REPRESENTS DESIGN INTENT ONLY. FABRICATOR WILL BE RESPONSIBLE TO VERIFY ALL CONDITIONS IN FIELD PRIOR TO SHOP DRAWINGS. REFER TO SIGN LOCATION PLAN AND MESSAGE SCHEDULE FOR SIGN TYPES AND LOCATIONS.

Client/Project		Project No.
Western Michigan University Signage Bid Document		14WMU249001
Date	Revisions	Scale
12.12.16		As noted

Gateway signs

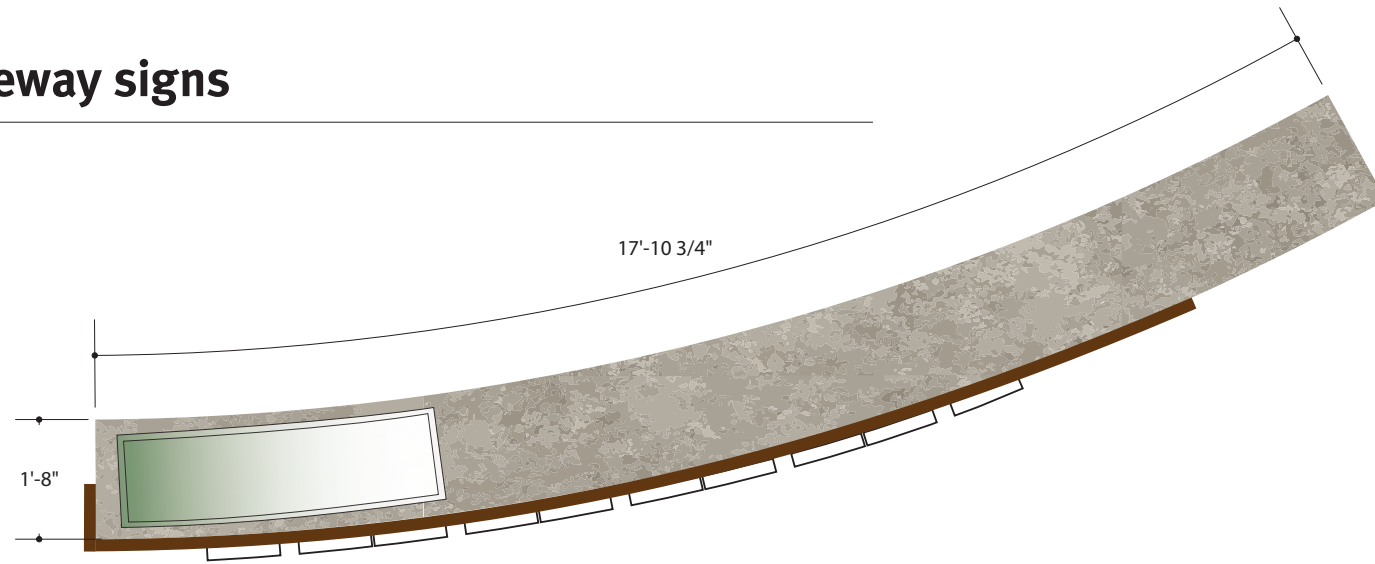

2 Plan view
scale: 3/8" = 1'-0"

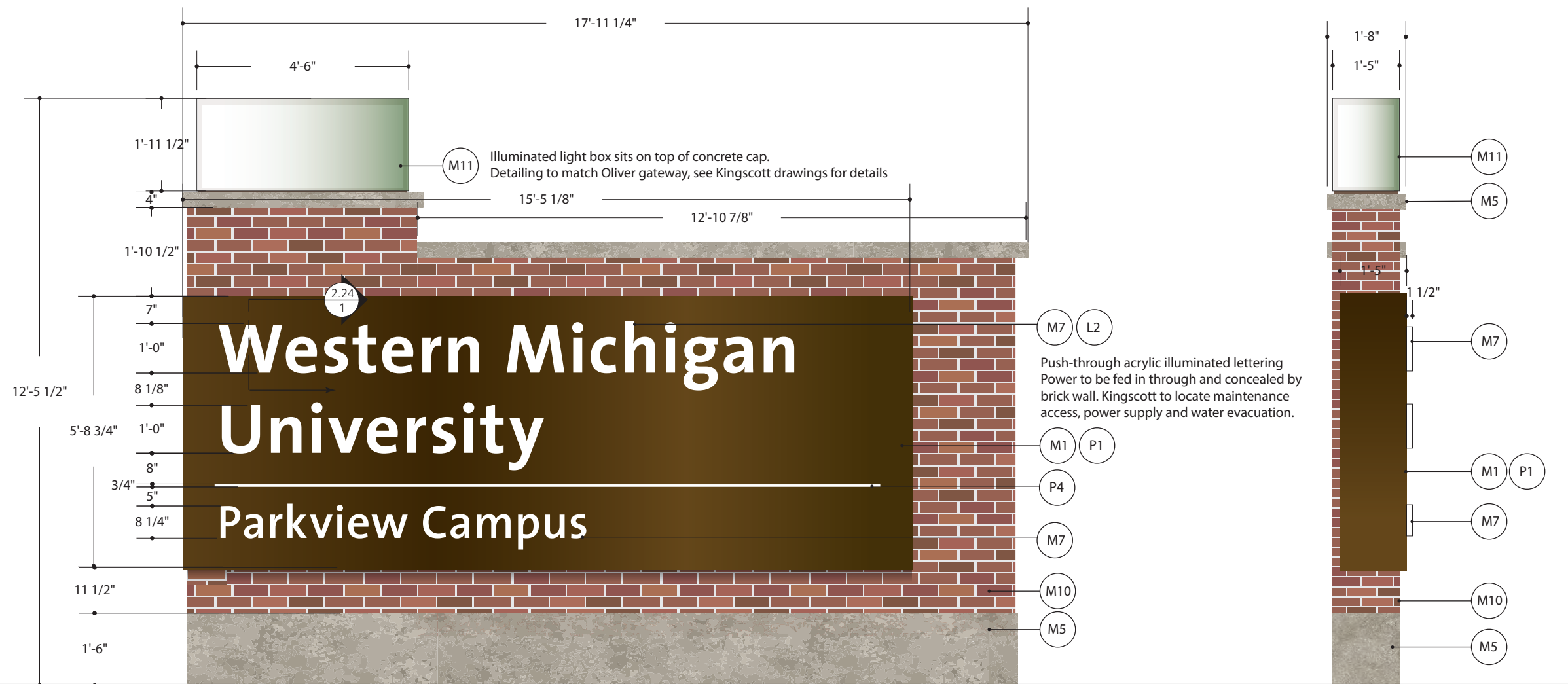

1 GW6 elevation
scale: 3/8" = 1'-0"

3 Side view
scale: 3/8" = 1'-0"

THIS DRAWING REPRESENTS DESIGN INTENT ONLY. FABRICATOR WILL BE RESPONSIBLE TO VERIFY ALL CONDITIONS IN FIELD PRIOR TO SHOP DRAWINGS. REFER TO SIGN LOCATION PLAN AND MESSAGE SCHEDULE FOR SIGN TYPES AND LOCATIONS.

Client/Project Western Michigan University Signage Bid Document		Project No. 14WMU249001
Date 12.12.16	Revisions	Scale As noted

Section 3 **Design Intent Drawings: Sign System**

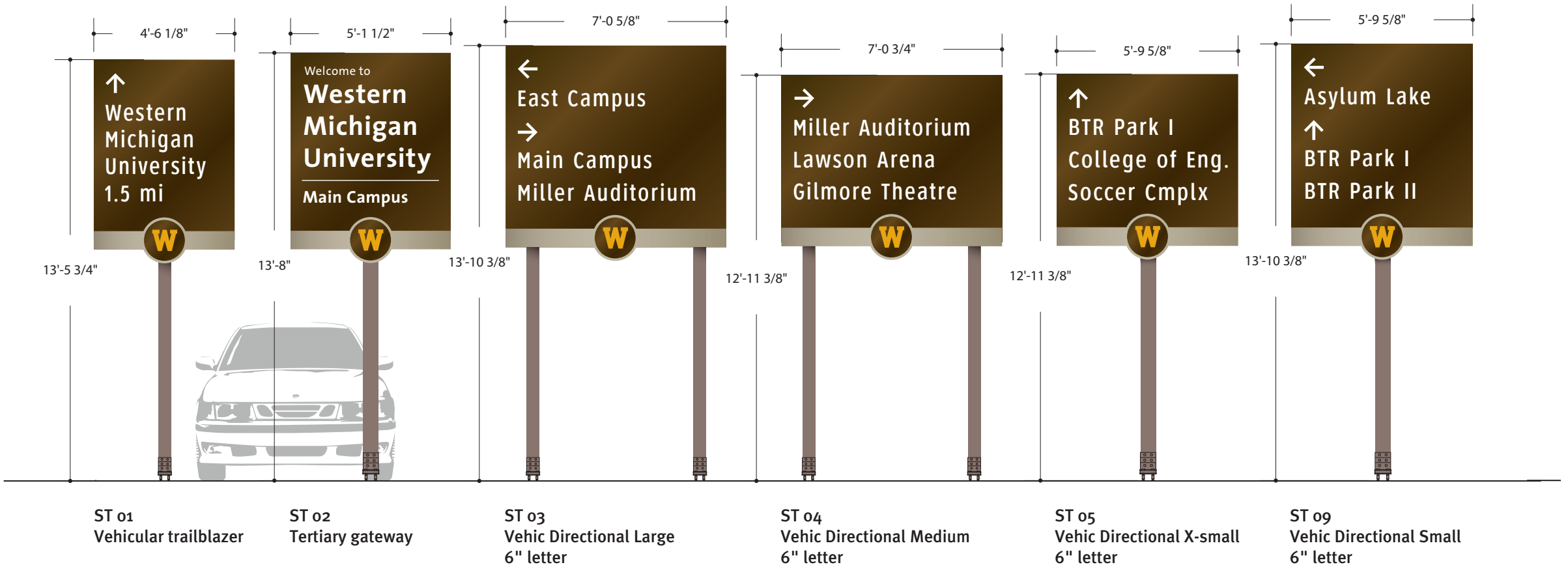

THIS DRAWING REPRESENTS DESIGN INTENT ONLY.
FABRICATOR WILL BE RESPONSIBLE TO VERIFY ALL
CONDITIONS IN FIELD PRIOR TO SHOP DRAWINGS.
REFER TO SIGN LOCATION PLAN AND MESSAGE
SCHEDULE FOR SIGN TYPES AND LOCATIONS.

Client/Project Western Michigan University Signage Bid Document		Project No. 14WMU249001
Date 12.12.16	Revisions	Scale As noted



ST 14
Parking regulatory
ST14A - single-faced
ST14B - double-faced

ST 16
Parking regulatory

ST 17
Parking Garage ID
ST17A - single-faced
ST17B - double-faced

ST 20
Street ID

THIS DRAWING REPRESENTS DESIGN INTENT ONLY. FABRICATOR WILL BE RESPONSIBLE TO VERIFY ALL CONDITIONS IN FIELD PRIOR TO SHOP DRAWINGS. REFER TO SIGN LOCATION PLAN AND MESSAGE SCHEDULE FOR SIGN TYPES AND LOCATIONS.

Client/Project		Project No.
Western Michigan University Signage Bid Document		14WMU249001
Date	Revisions	Scale
12.12.16		As noted



5
ling directory

ST 26
Building directory
freestanding
ST26A - single-faced
ST26B - double-faced

ST 27
Pedestrian directional
with map

ST 29
Pedestrian directional

THIS DRAWING REPRESENTS DESIGN INTENT ONLY. FABRICATOR WILL BE RESPONSIBLE TO VERIFY ALL CONDITIONS IN FIELD PRIOR TO SHOP DRAWINGS. REFER TO SIGN LOCATION PLAN AND MESSAGE SCHEDULE FOR SIGN TYPES AND LOCATIONS.

Client/Project Western Michigan University Signage Bid Document		Project No. 14WMU249001
Date 12.12.16	Revisions	Scale As noted

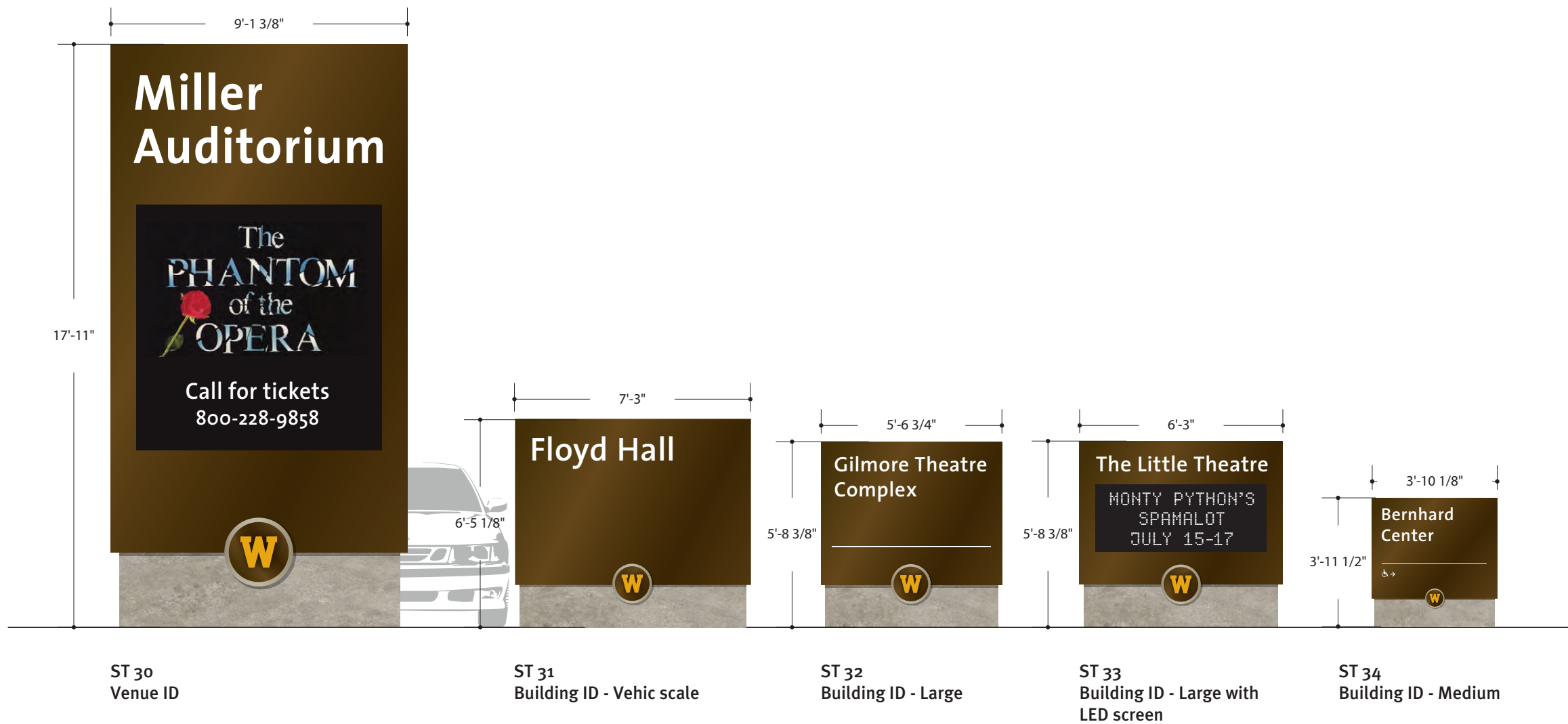

THIS DRAWING REPRESENTS DESIGN INTENT ONLY. FABRICATOR WILL BE RESPONSIBLE TO VERIFY ALL CONDITIONS IN FIELD PRIOR TO SHOP DRAWINGS. REFER TO SIGN LOCATION PLAN AND MESSAGE SCHEDULE FOR SIGN TYPES AND LOCATIONS.

Client/Project		Project No.
Western Michigan University Signage Bid Document		14WMU249001
Date	Revisions	Scale
12.12.16		As noted

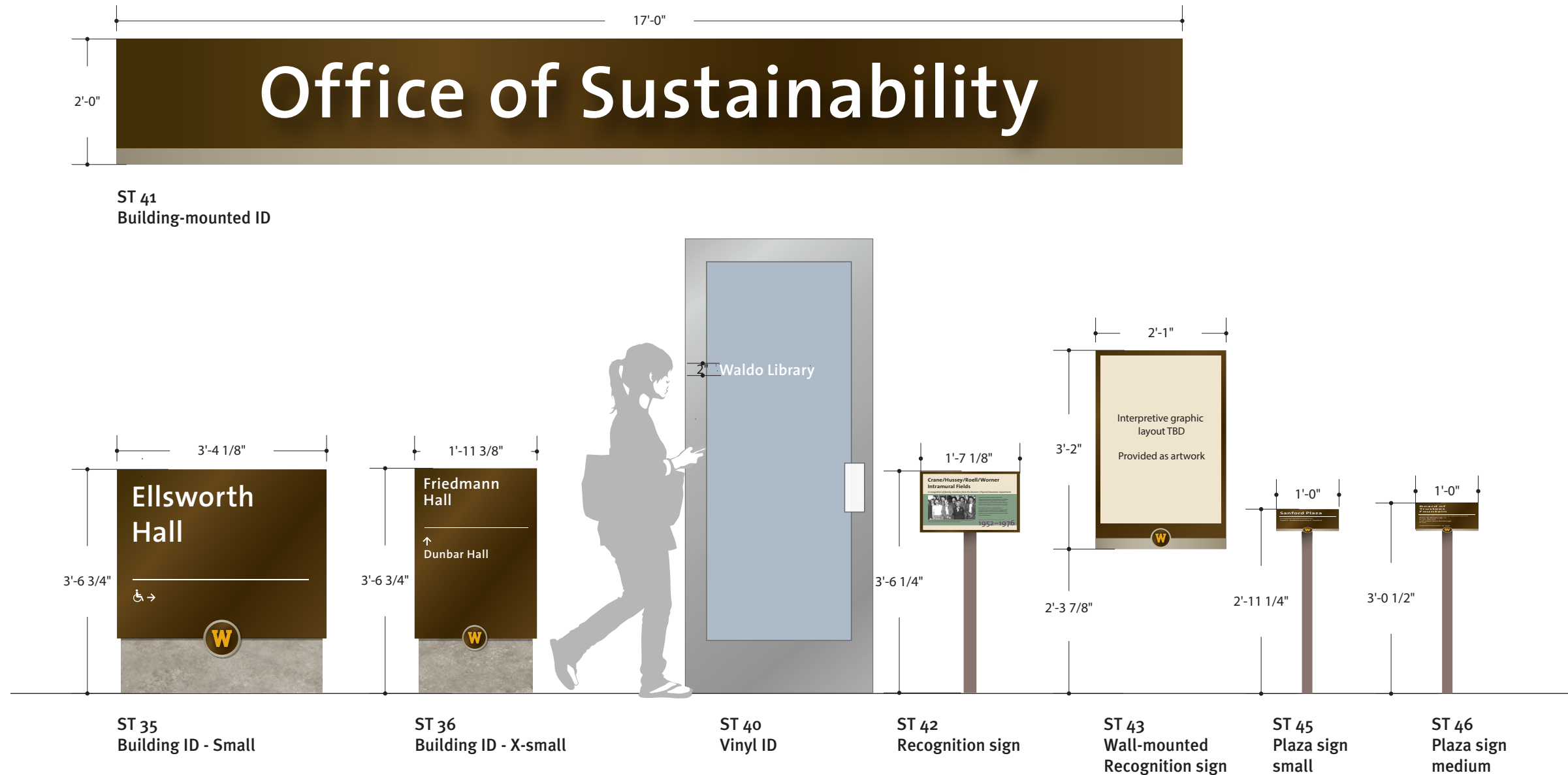

THIS DRAWING REPRESENTS DESIGN INTENT ONLY.
 FABRICATOR WILL BE RESPONSIBLE TO VERIFY ALL
 CONDITIONS IN FIELD PRIOR TO SHOP DRAWINGS.
 REFER TO SIGN LOCATION PLAN AND MESSAGE
 SCHEDULE FOR SIGN TYPES AND LOCATIONS.

Client/Project Western Michigan University Signage Bid Document		Project No. 14WMU249001
Date 12.12.16	Revisions	Scale As noted

Type size guide for campus roads

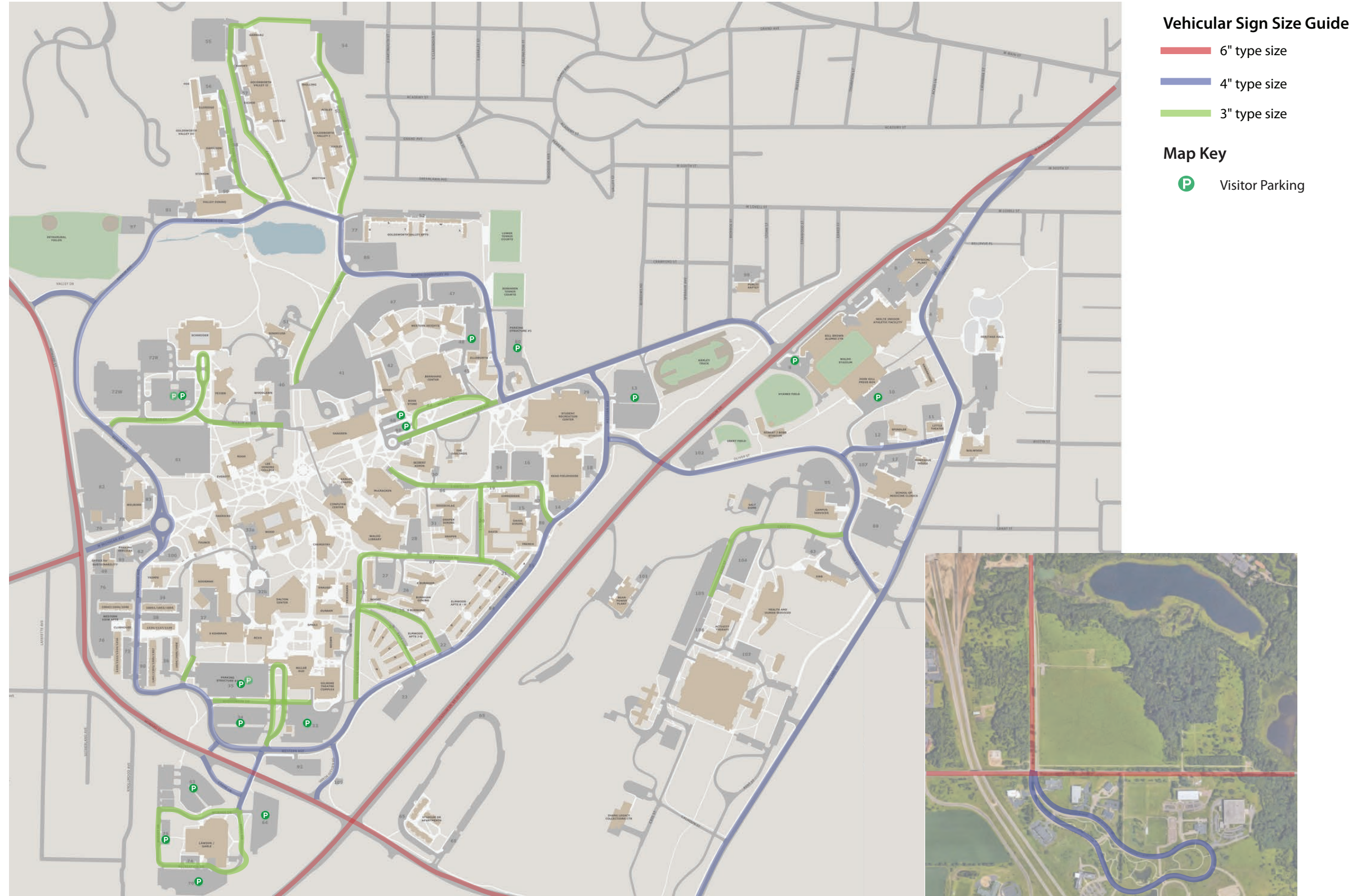

THIS DRAWING REPRESENTS DESIGN INTENT ONLY. FABRICATOR WILL BE RESPONSIBLE TO VERIFY ALL CONDITIONS IN FIELD PRIOR TO SHOP DRAWINGS. REFER TO SIGN LOCATION PLAN AND MESSAGE SCHEDULE FOR SIGN TYPES AND LOCATIONS.

Client/Project		Project No.
Western Michigan University Signage Bid Document		14WMU249001
Date	Revisions	Scale
12.12.16		As noted

ST 01 Vehicular trailblazer

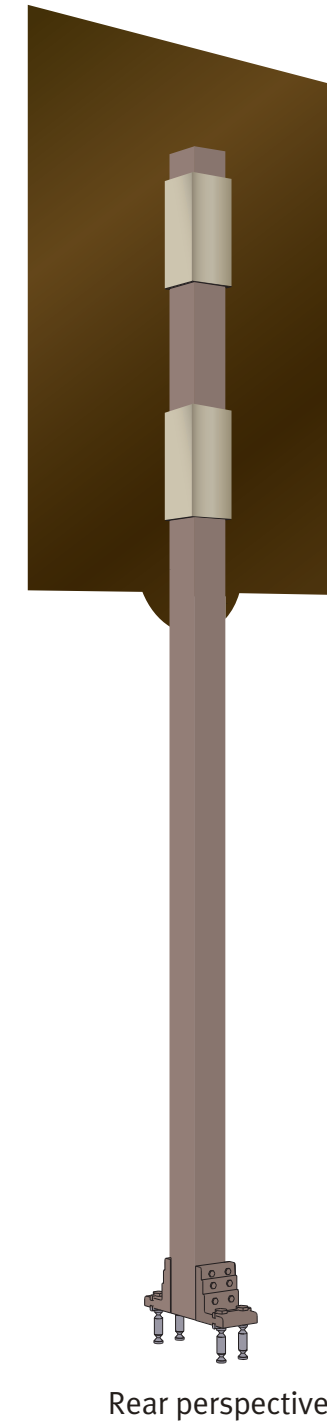
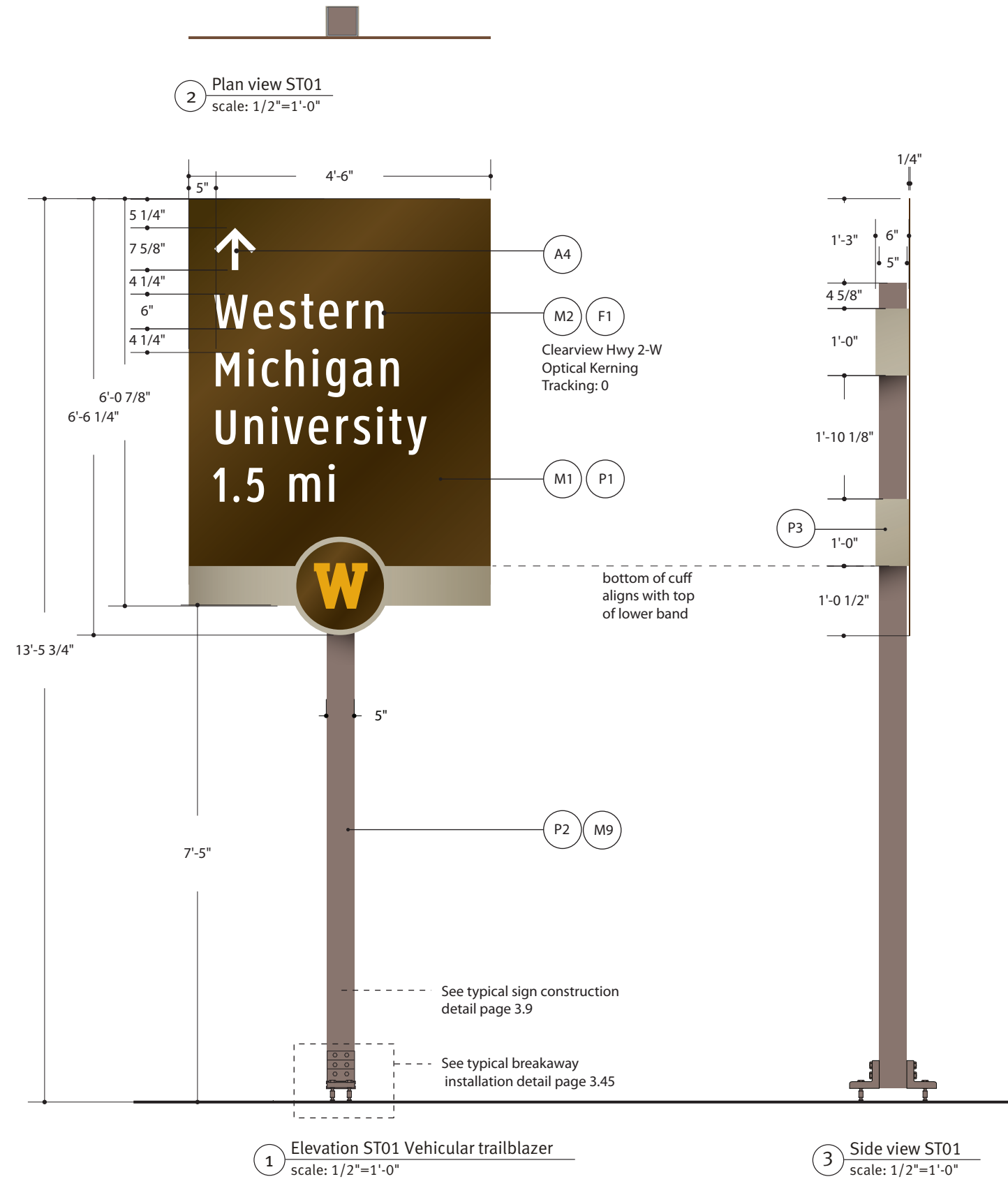

THIS DRAWING REPRESENTS DESIGN INTENT ONLY. FABRICATOR WILL BE RESPONSIBLE TO VERIFY ALL CONDITIONS IN FIELD PRIOR TO SHOP DRAWINGS. REFER TO SIGN LOCATION PLAN AND MESSAGE SCHEDULE FOR SIGN TYPES AND LOCATIONS.

Client/Project		Project No.
Western Michigan University Signage Bid Document		14WMU249001
Date	Revisions	Scale
12.12.16		As noted

Typical W band layout

DRAWINGS

3.8

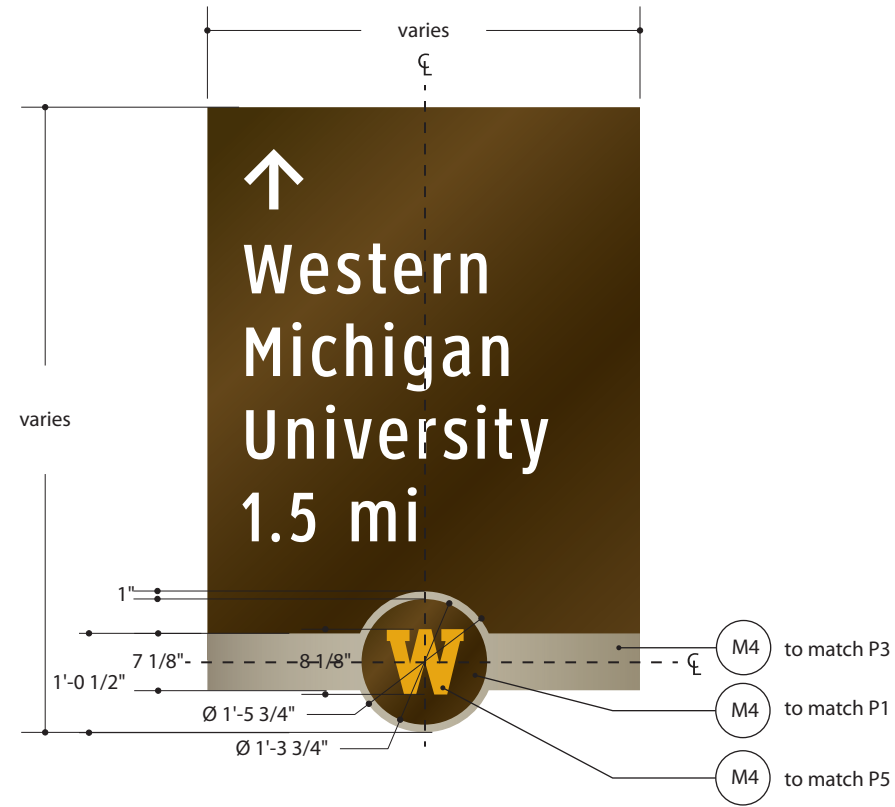

1 Typical W Band Layout - ST01, 03, 04, 05
scale: 1/2"=1'-0"

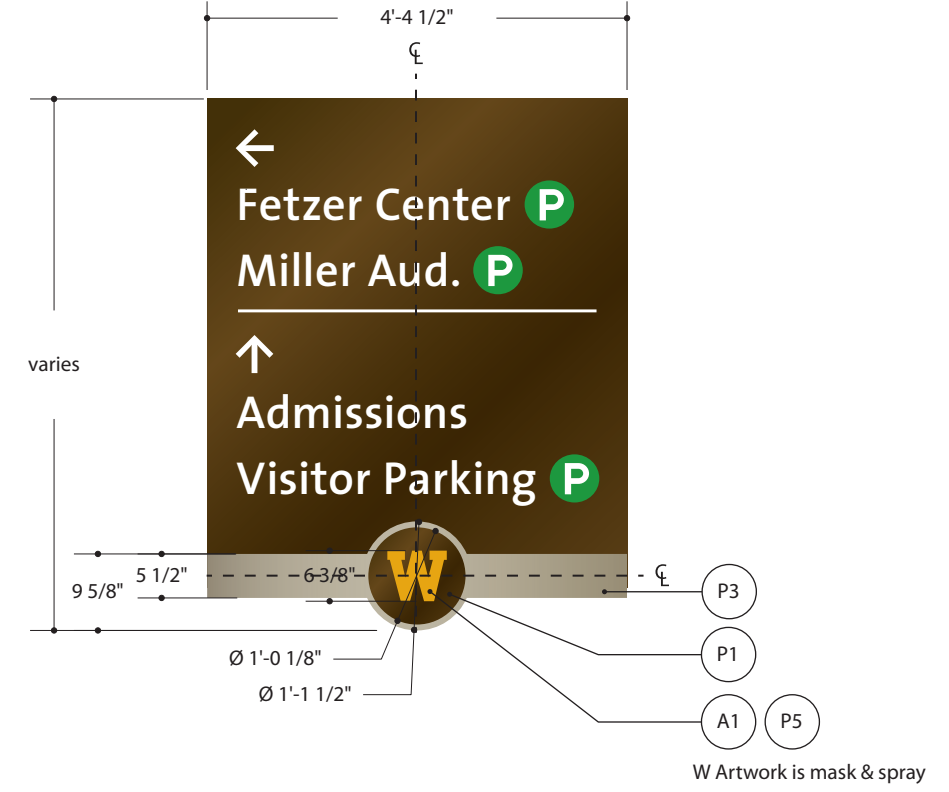

2 Typical W Band Layout - ST06, 10, 11
scale: 1/2"=1'-0"



3 Typical Parking Band Layout - ST14
scale: 1/2"=1'-0"

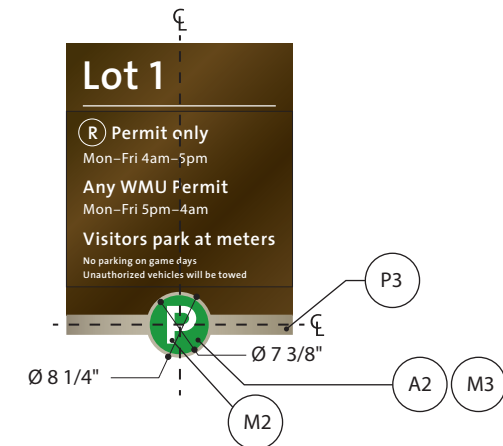

4 Typical Parking Band Layout - ST16
scale: 1/2"=1'-0"

THIS DRAWING REPRESENTS DESIGN INTENT ONLY. FABRICATOR WILL BE RESPONSIBLE TO VERIFY ALL CONDITIONS IN FIELD PRIOR TO SHOP DRAWINGS. REFER TO SIGN LOCATION PLAN AND MESSAGE SCHEDULE FOR SIGN TYPES AND LOCATIONS.

Client/Project		Project No.
Western Michigan University Signage Bid Document		14WMU249001
Date	Revisions	Scale
12.12.16		As noted

Typical Vehicular sign details

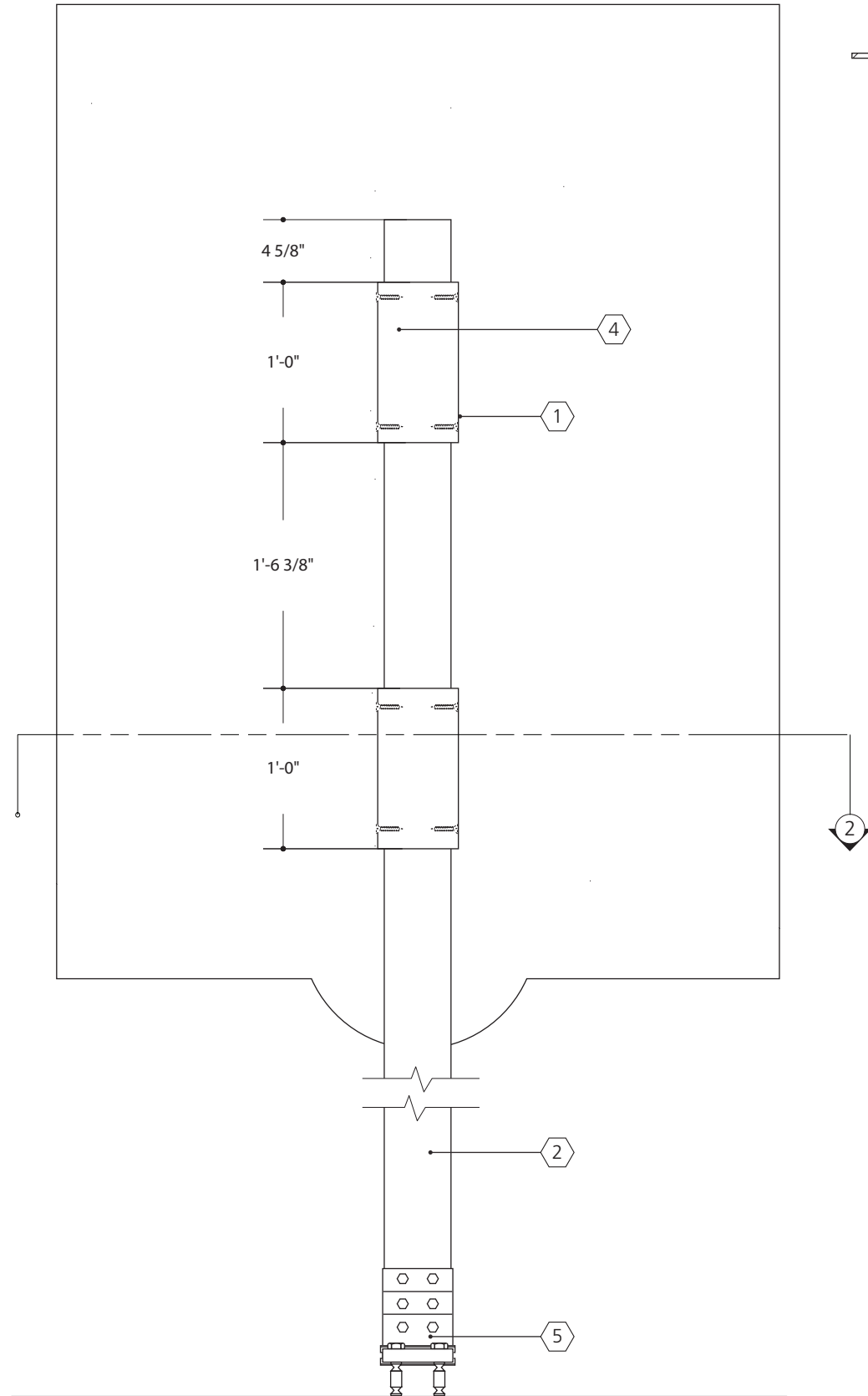

2 Plan Section
scale: 1 1/2"=1'-0"

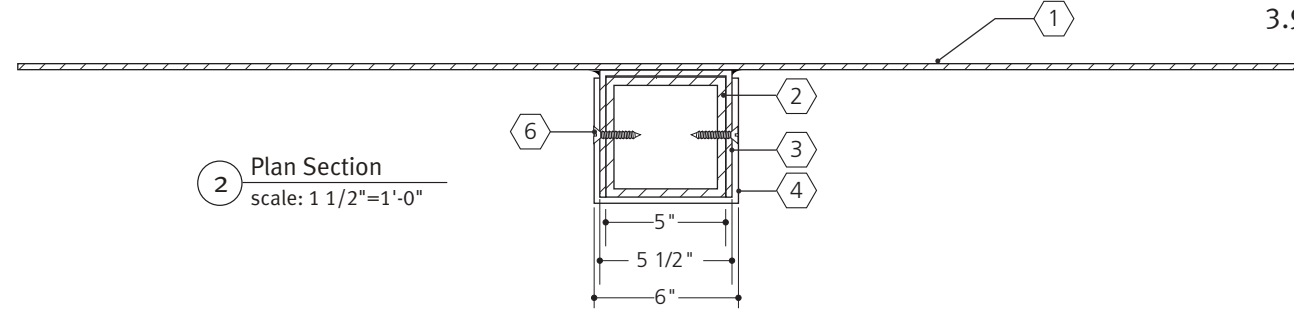

- 1 1/4" aluminum sign face welded to cuff
- 2 Extruded aluminum tube upright - 5" x 5" (typical) x 1/4" wall
- 3 Extruded aluminum tube cuff - 5 1/2" x 5 1/2" x 1/4" wall plug welded to sign face
- 4 Extruded aluminum tube cuff - 6" x 6" x 1/4" wall mechanically fastened to upright tube
- 5 Transpo B525 breakaway device
- 6 Mechanical fastener

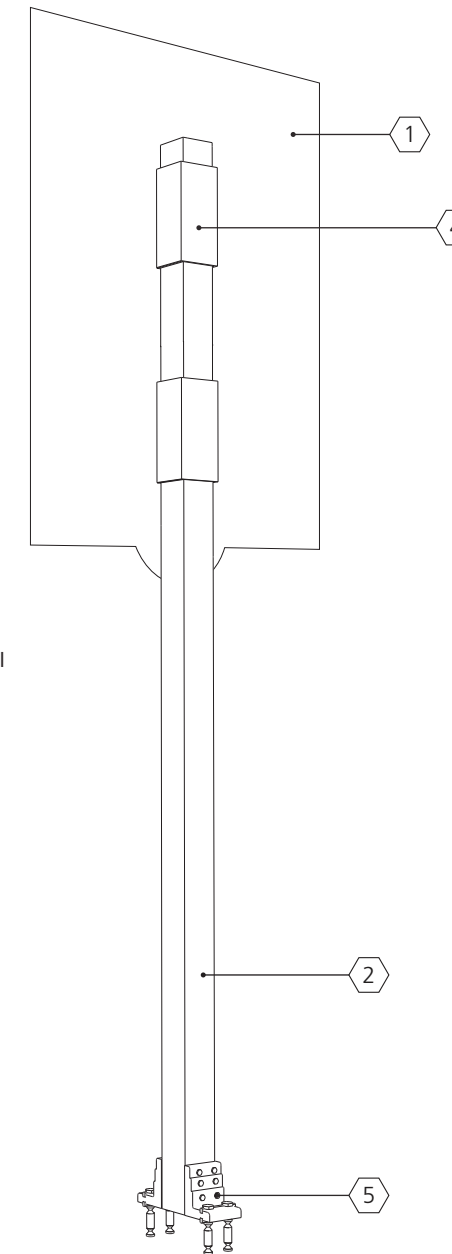

3 Rear perspective
n t s

THIS DRAWING REPRESENTS DESIGN INTENT ONLY. FABRICATOR WILL BE RESPONSIBLE TO VERIFY ALL CONDITIONS IN FIELD PRIOR TO SHOP DRAWINGS. REFER TO SIGN LOCATION PLAN AND MESSAGE SCHEDULE FOR SIGN TYPES AND LOCATIONS.

1 Detail ST01
scale: 1"=1'-0"

Client/Project Western Michigan University Signage Bid Document		Project No. 14WMU249001
Date 12.12.16	Revisions	Scale As noted

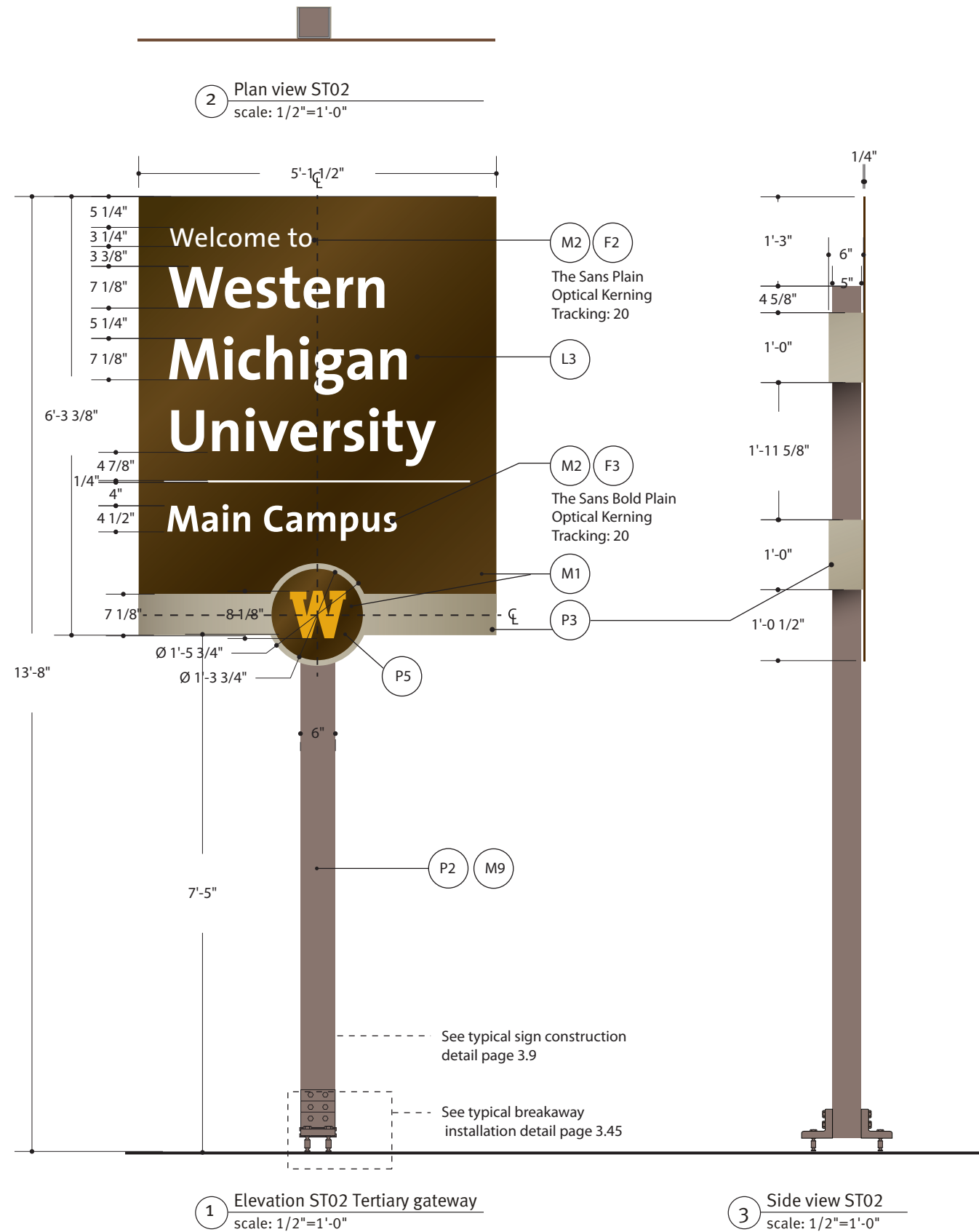

THIS DRAWING REPRESENTS DESIGN INTENT ONLY. FABRICATOR WILL BE RESPONSIBLE TO VERIFY ALL CONDITIONS IN FIELD PRIOR TO SHOP DRAWINGS. REFER TO SIGN LOCATION PLAN AND MESSAGE SCHEDULE FOR SIGN TYPES AND LOCATIONS.

Client/Project		Project No.
Western Michigan University Signage Bid Document		14WMU249001
Date	Revisions	Scale
12.12.16		As noted

ST 03 Off-campus Vehicular directional - Large

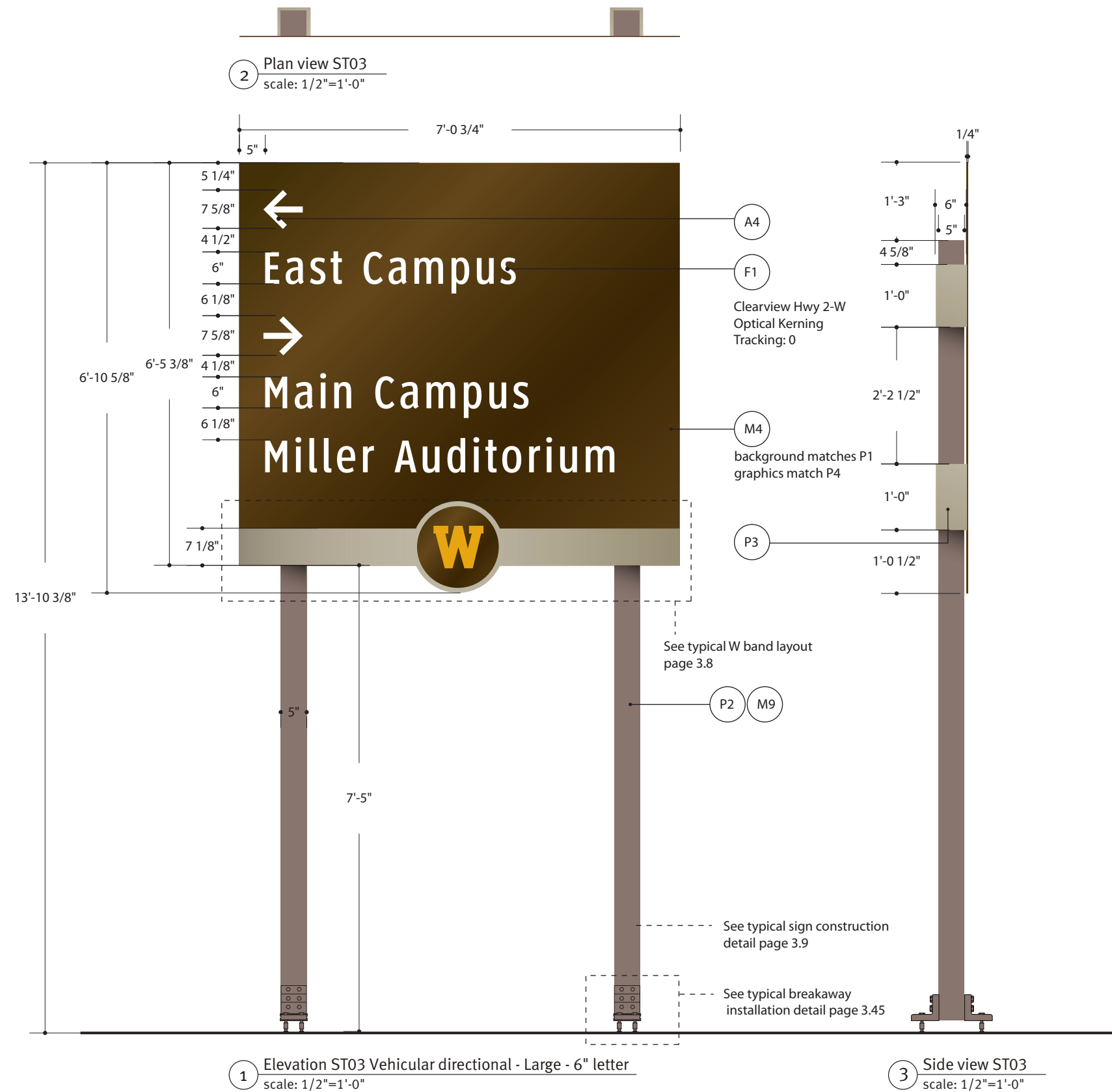

THIS DRAWING REPRESENTS DESIGN INTENT ONLY. FABRICATOR WILL BE RESPONSIBLE TO VERIFY ALL CONDITIONS IN FIELD PRIOR TO SHOP DRAWINGS. REFER TO SIGN LOCATION PLAN AND MESSAGE SCHEDULE FOR SIGN TYPES AND LOCATIONS.

Client/Project Western Michigan University Signage Bid Document		Project No. 14WMU249001
Date 12.12.16	Revisions	Scale As noted



THIS DRAWING REPRESENTS DESIGN INTENT ONLY. FABRICATOR WILL BE RESPONSIBLE TO VERIFY ALL CONDITIONS IN FIELD PRIOR TO SHOP DRAWINGS. REFER TO SIGN LOCATION PLAN AND MESSAGE SCHEDULE FOR SIGN TYPES AND LOCATIONS.

Client/Project		Project No.
Western Michigan University Signage Bid Document		14WMU249001
Date	Revisions	Scale
12.12.16		As noted

ST 05 Off-campus Vehicular directional - Small

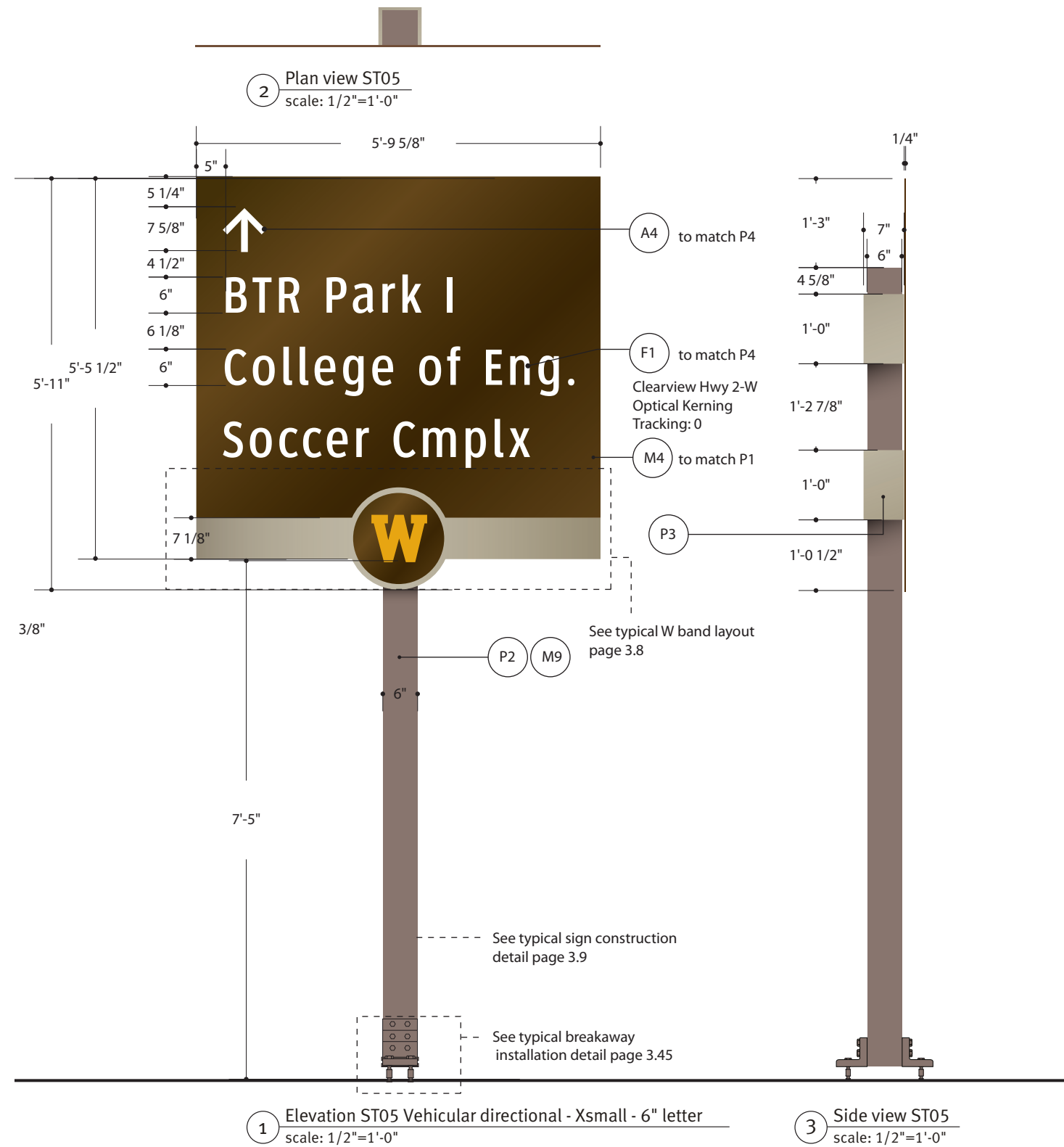

THIS DRAWING REPRESENTS DESIGN INTENT ONLY. FABRICATOR WILL BE RESPONSIBLE TO VERIFY ALL CONDITIONS IN FIELD PRIOR TO SHOP DRAWINGS. REFER TO SIGN LOCATION PLAN AND MESSAGE SCHEDULE FOR SIGN TYPES AND LOCATIONS.

Client/Project Western Michigan University Signage Bid Document		Project No. 14WMU249001
Date 12.12.16	Revisions	Scale As noted

ST 06 On-campus Vehicular directional - Large

DRAWINGS

3.14

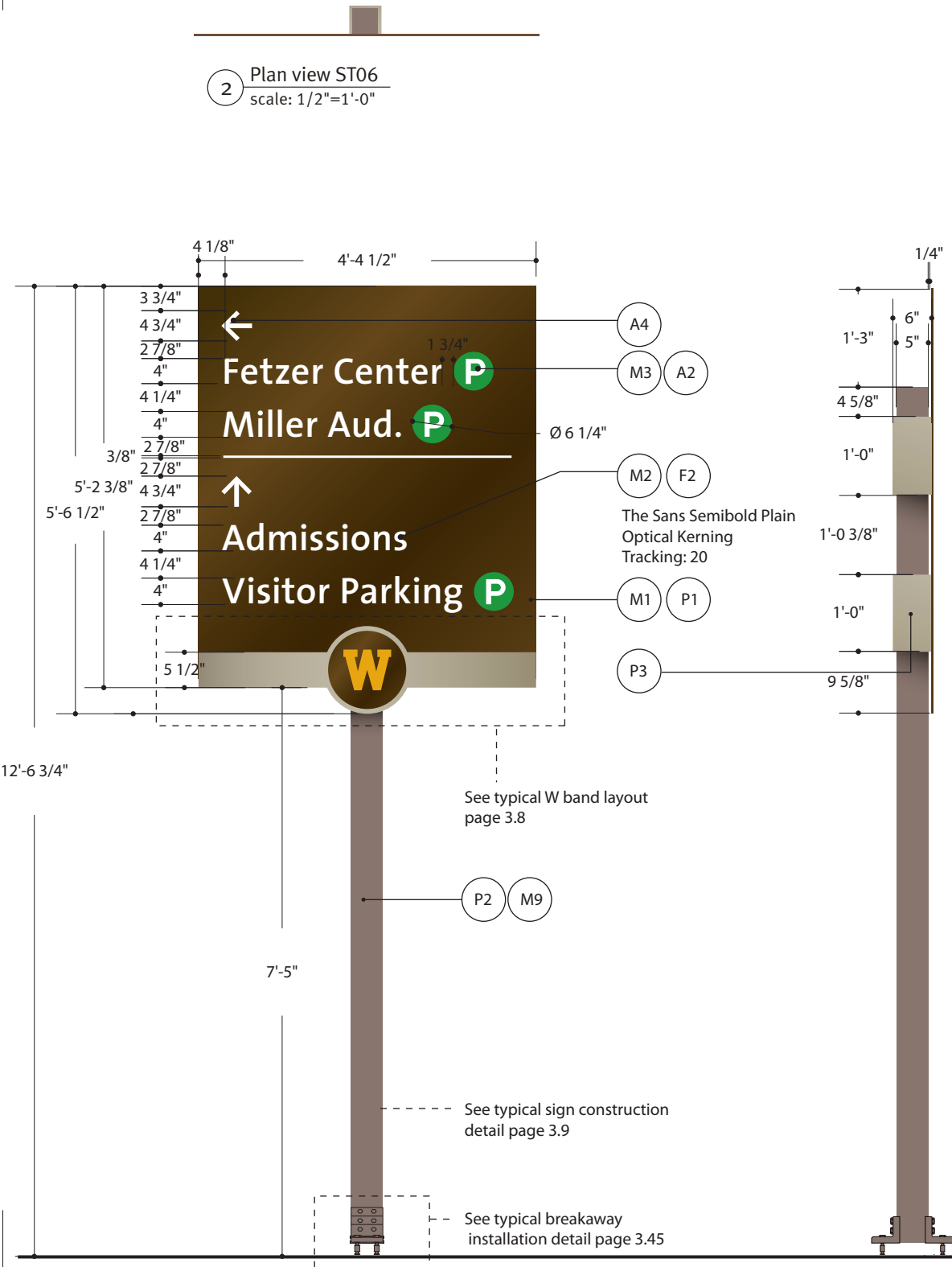

1 Elevation ST06 Vehicular directional - Large - 4" letter
scale: 1/2"=1'-0"

3 Side view ST06
scale: 1/2"=1'-0"

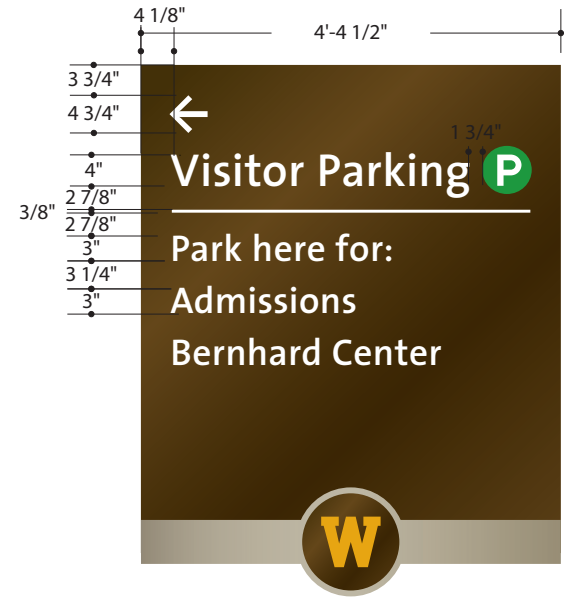

4 Elevation ST06 - Alternate layouts
scale: 1/2"=1'-0"

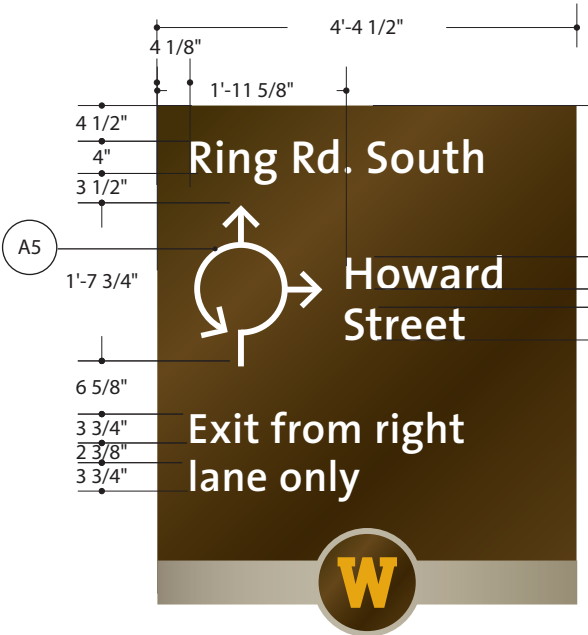

5 Elevation ST06 - Traffic circle layouts
scale: 1/2"=1'-0"

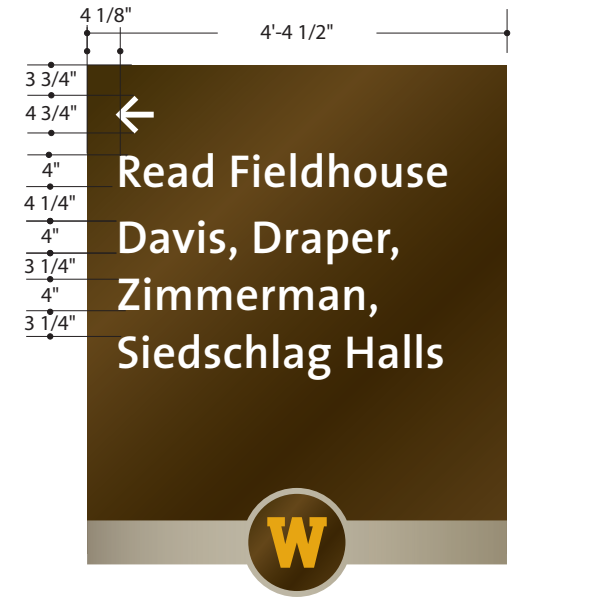

THIS DRAWING REPRESENTS DESIGN INTENT ONLY. FABRICATOR WILL BE RESPONSIBLE TO VERIFY ALL CONDITIONS IN FIELD PRIOR TO SHOP DRAWINGS. REFER TO SIGN LOCATION PLAN AND MESSAGE SCHEDULE FOR SIGN TYPES AND LOCATIONS.

Client/Project Western Michigan University Signage Bid Document		Project No. 14WMU249001
Date 12.12.16	Revisions	Scale As noted

ST 07 and St 08 - Ring Road Blazes

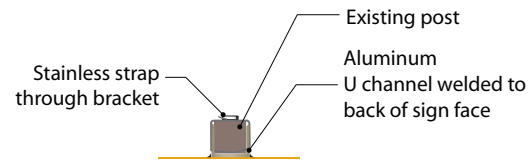

2 Plan view ST07
scale: 1/2"=1'-0"

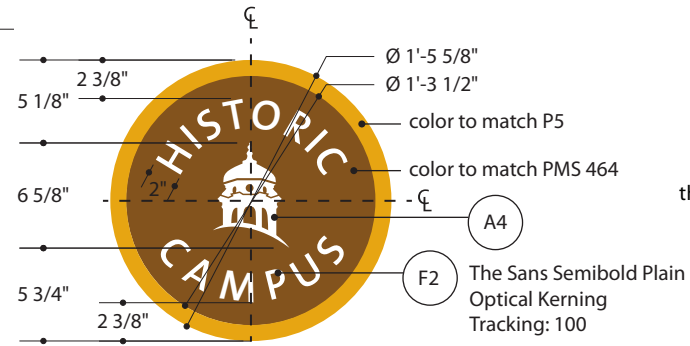

4 Layout ST07 - Historic Campus version
scale: 1"=1'-0"

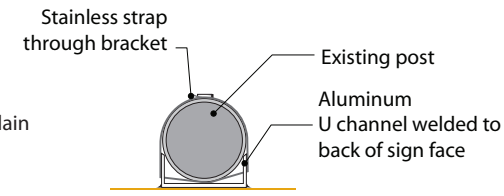

6 Plan view ST08
scale: 1/2"=1'-0"

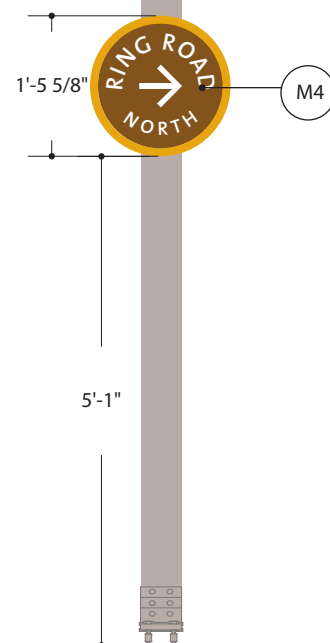
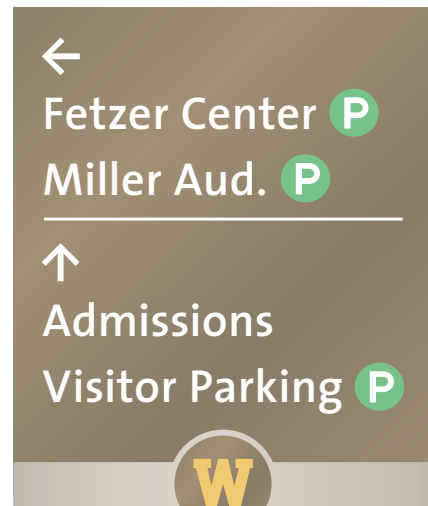

1 Elevation ST07 Ring Road Blaze - Small
scale: 1/2"=1'-0"

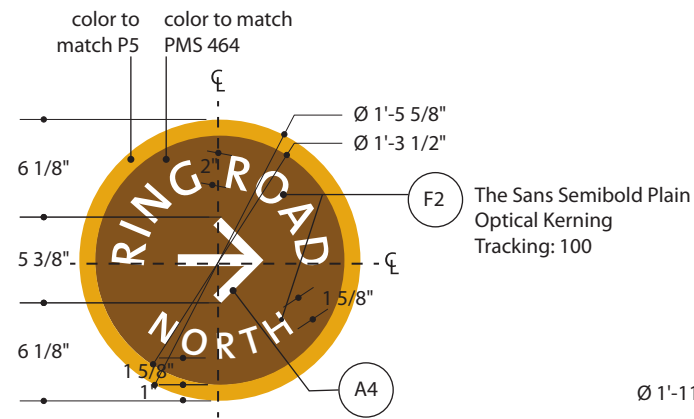

4 Layout ST07 - Ring Road version
scale: 1"=1'-0"

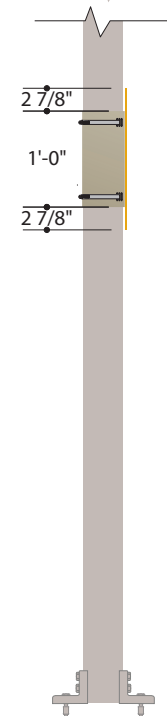

3 Side view ST07
scale: 1/2"=1'-0"

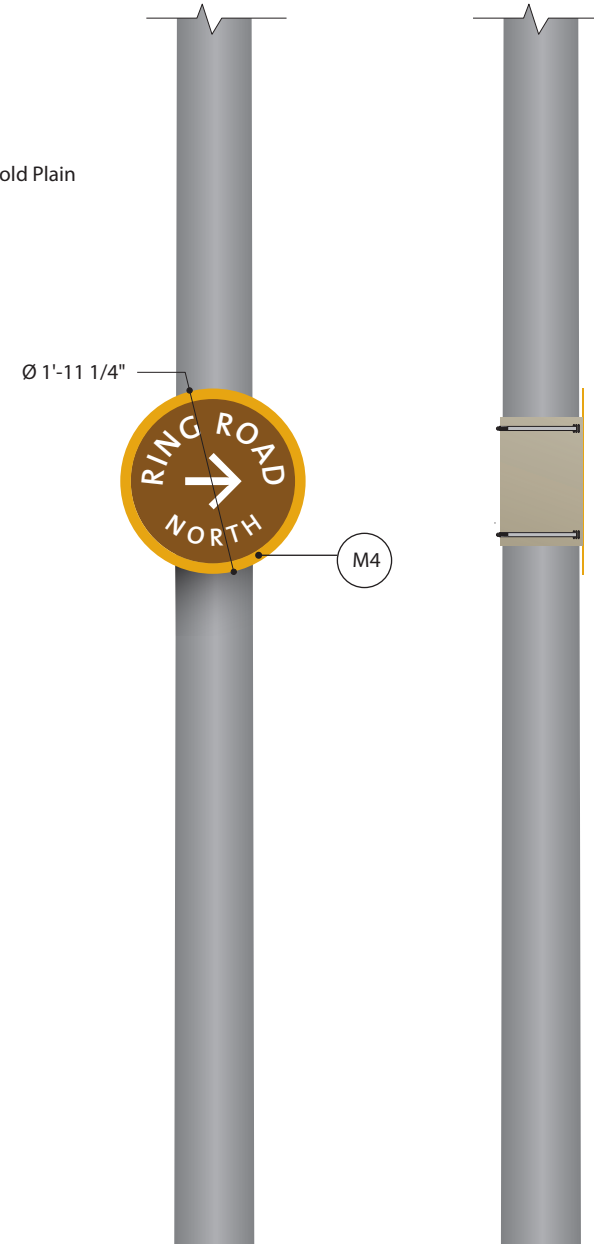

5 Elevation ST08
Ring Road Blaze - Large
scale: 1/2"=1'-0"

7 Side view ST08
scale: 1/2"=1'-0"

THIS DRAWING REPRESENTS DESIGN INTENT ONLY. FABRICATOR WILL BE RESPONSIBLE TO VERIFY ALL CONDITIONS IN FIELD PRIOR TO SHOP DRAWINGS. REFER TO SIGN LOCATION PLAN AND MESSAGE SCHEDULE FOR SIGN TYPES AND LOCATIONS.

Client/Project Western Michigan University Signage Bid Document		Project No. 14WMU249001
Date 12.12.16	Revisions	Scale As noted

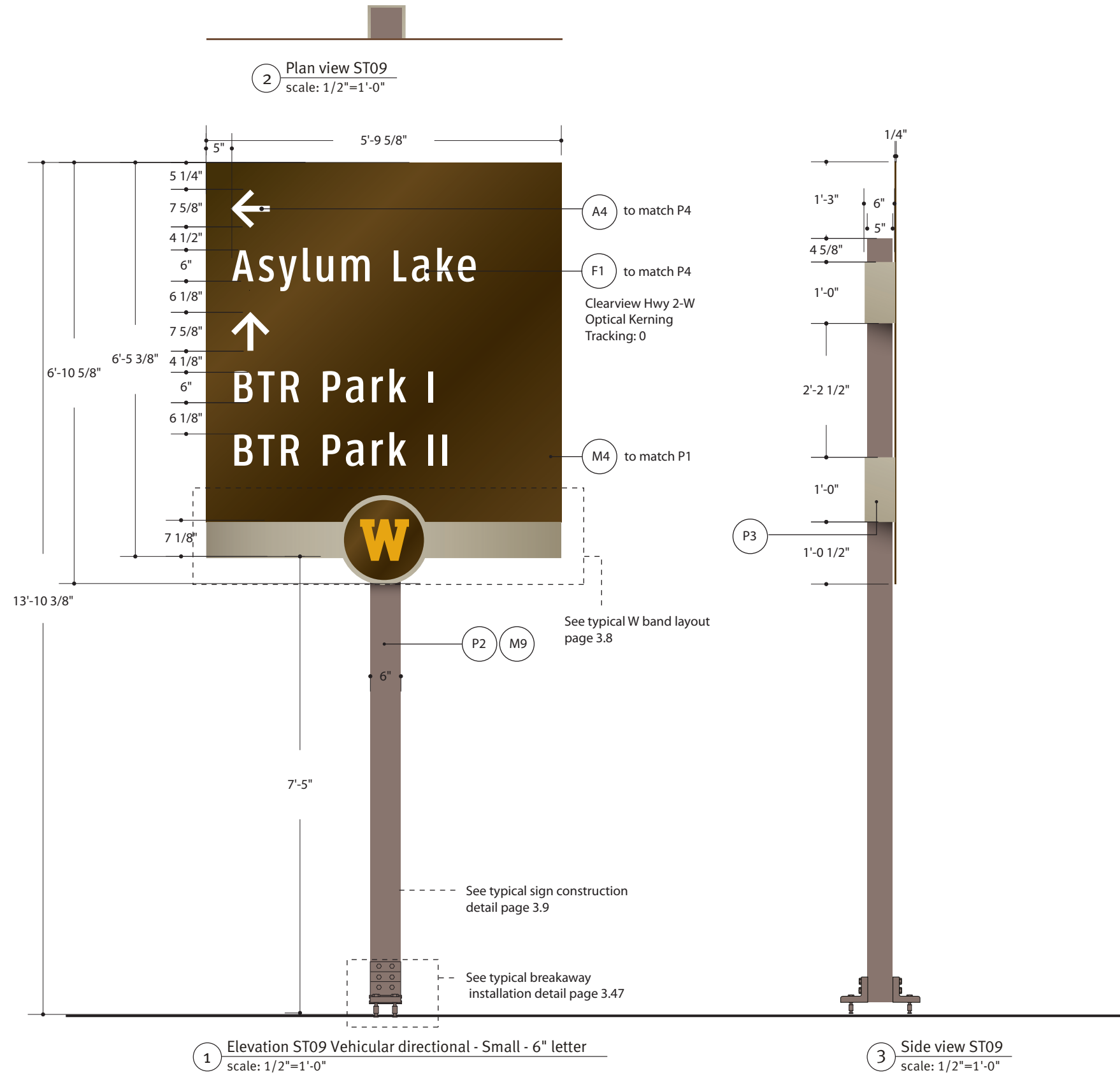

THIS DRAWING REPRESENTS DESIGN INTENT ONLY. FABRICATOR WILL BE RESPONSIBLE TO VERIFY ALL CONDITIONS IN FIELD PRIOR TO SHOP DRAWINGS. REFER TO SIGN LOCATION PLAN AND MESSAGE SCHEDULE FOR SIGN TYPES AND LOCATIONS.

Client/Project		Project No.
Western Michigan University Signage Bid Document		14WMU249001
Date	Revisions	Scale
12.12.16		As noted

ST 10 On-campus Vehicular directional

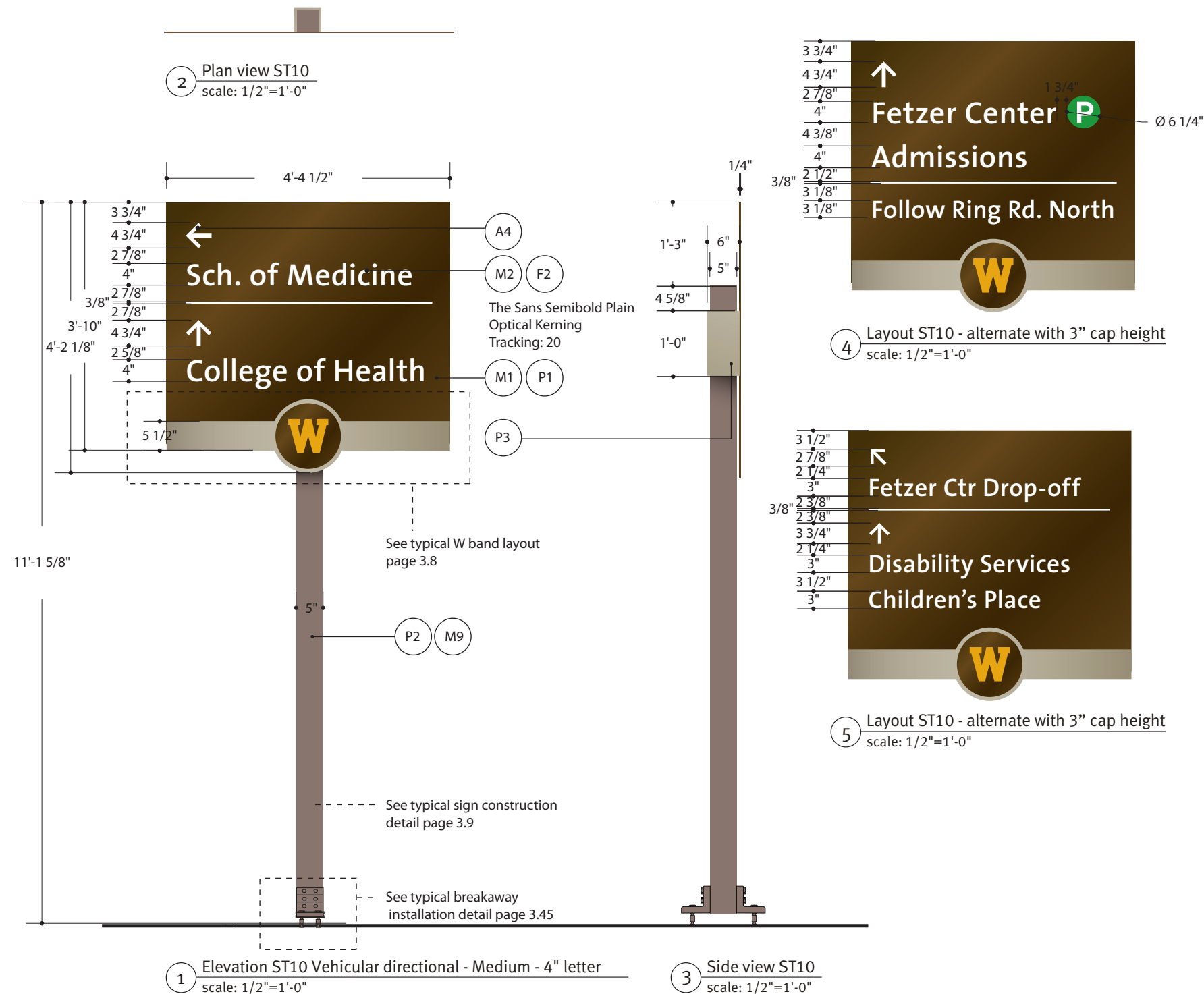

THIS DRAWING REPRESENTS DESIGN INTENT ONLY. FABRICATOR WILL BE RESPONSIBLE TO VERIFY ALL CONDITIONS IN FIELD PRIOR TO SHOP DRAWINGS. REFER TO SIGN LOCATION PLAN AND MESSAGE SCHEDULE FOR SIGN TYPES AND LOCATIONS.

Client/Project Western Michigan University Signage Bid Document		Project No. 14WMU249001
Date 12.12.16	Revisions	Scale As noted

ST 11 On-campus Vehicular directional with digital screen

DRAWINGS

3.18

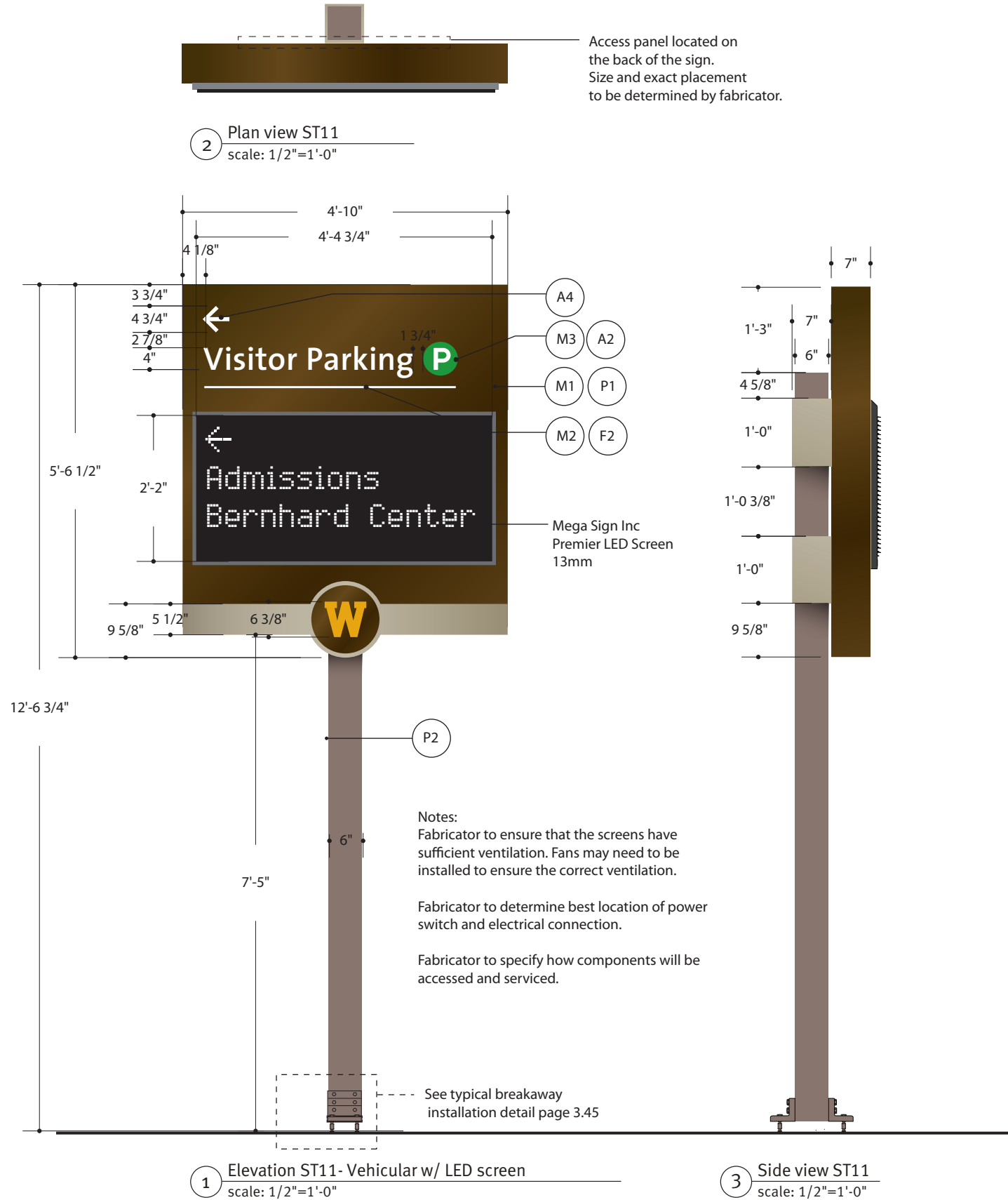

THIS DRAWING REPRESENTS DESIGN INTENT ONLY. FABRICATOR WILL BE RESPONSIBLE TO VERIFY ALL CONDITIONS IN FIELD PRIOR TO SHOP DRAWINGS. REFER TO SIGN LOCATION PLAN AND MESSAGE SCHEDULE FOR SIGN TYPES AND LOCATIONS.

Client/Project Western Michigan University Signage Bid Document		Project No. 14WMU249001
Date 12.12.16	Revisions	Scale As noted

ST 12 On-campus Vehicular directional

3.19

DRAWINGS

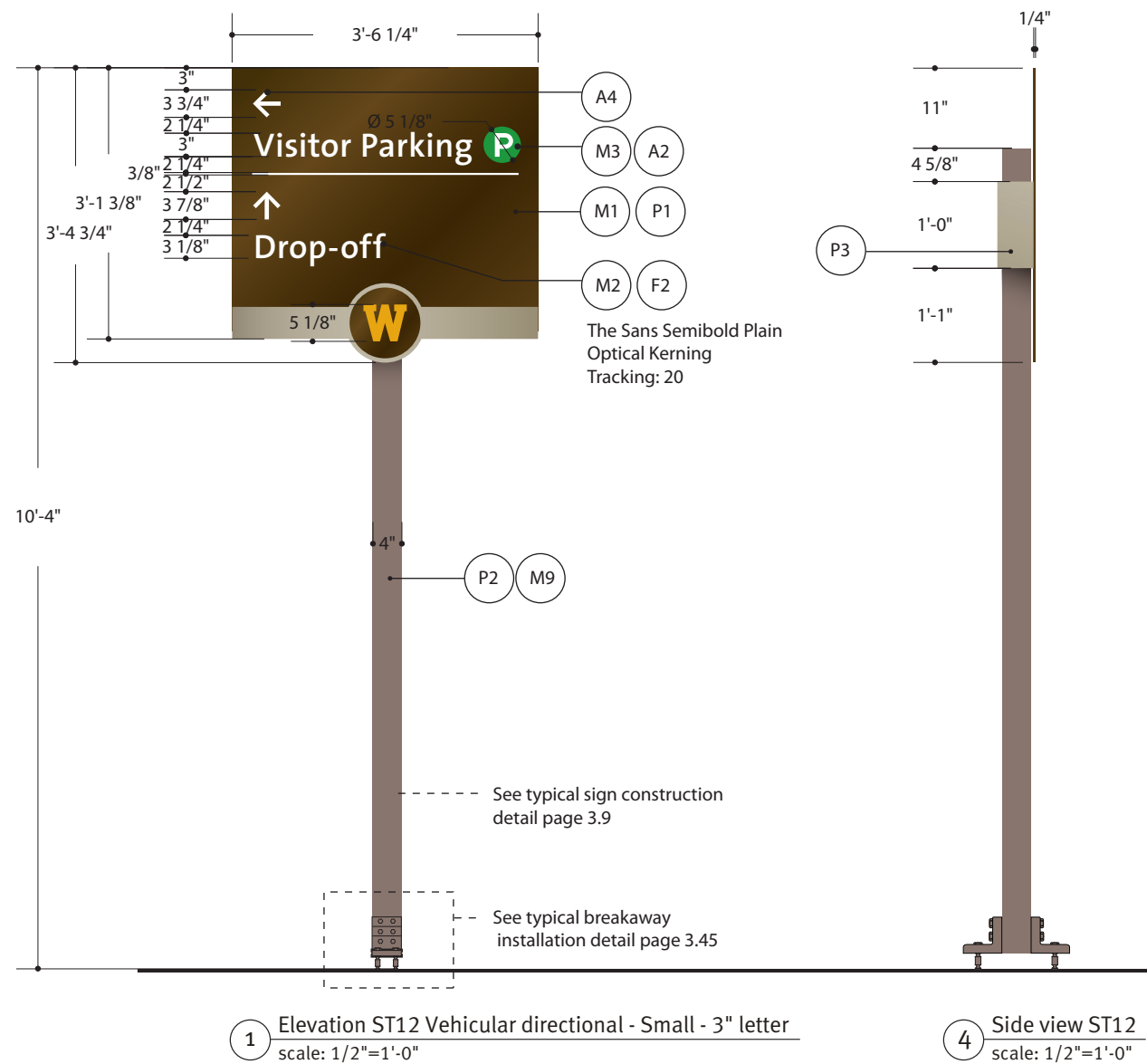
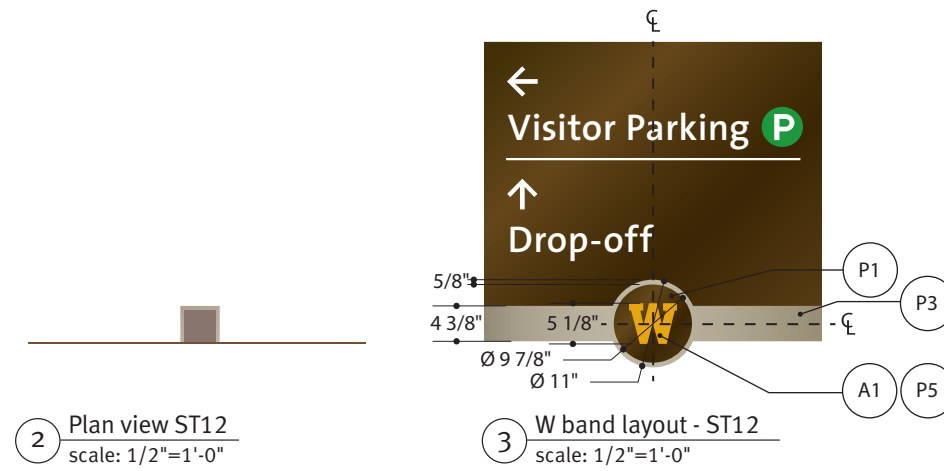

THIS DRAWING REPRESENTS DESIGN INTENT ONLY. FABRICATOR WILL BE RESPONSIBLE TO VERIFY ALL CONDITIONS IN FIELD PRIOR TO SHOP DRAWINGS. REFER TO SIGN LOCATION PLAN AND MESSAGE SCHEDULE FOR SIGN TYPES AND LOCATIONS.

Client/Project Western Michigan University Signage Bid Document		Project No. 14WMU249001
Date 12.12.16	Revisions	Scale As noted

ST 14A Parking Regulatory

3.21

DRAWINGS

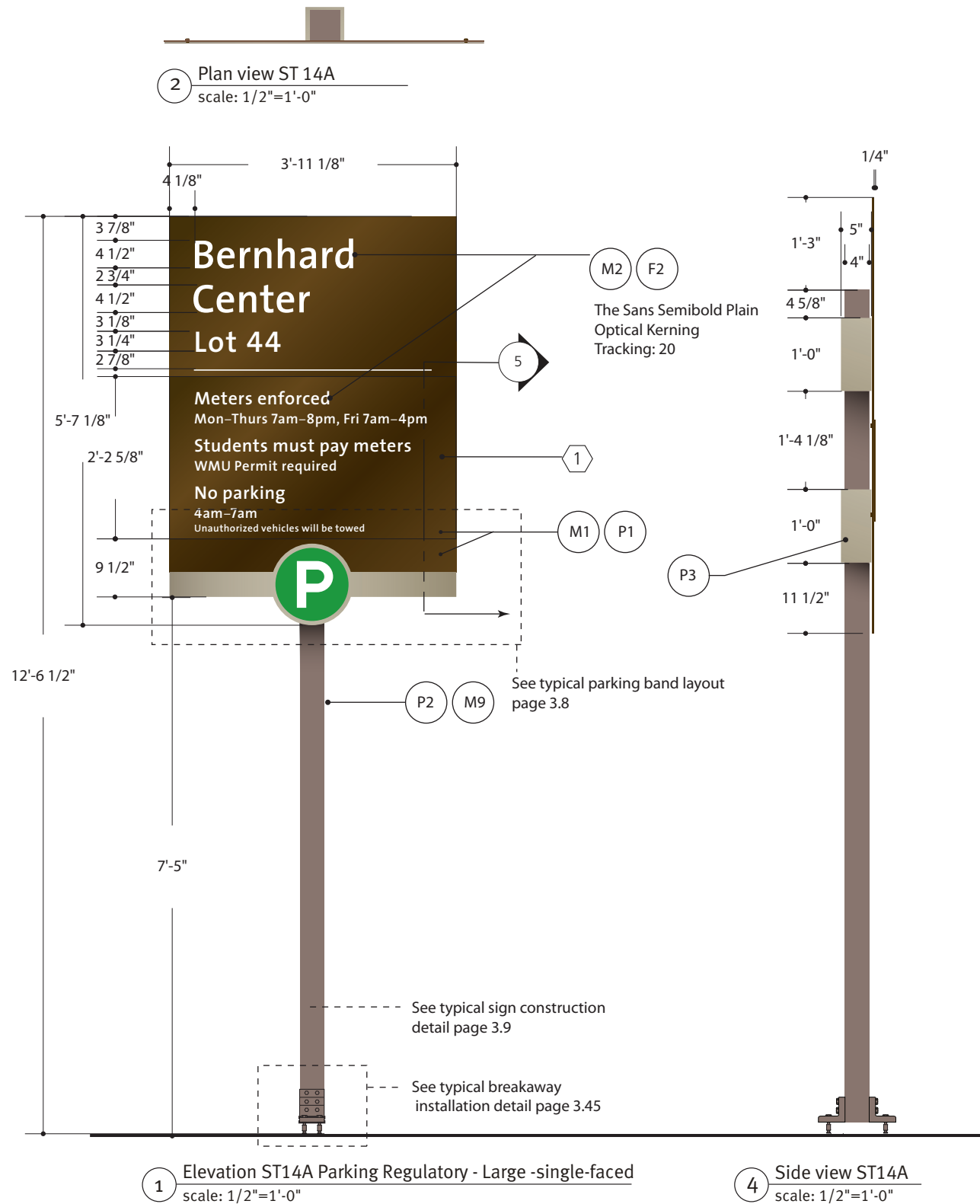

- 1 1/4" thick removable, painted aluminum panel with applied message
- 2 Fillet-weld threaded stud into back side of aluminum panel
- 3 Threaded stud inserted into threaded holes with tamper-proof nut, fabricator to provide details for review
- 4 1/4" thick painted aluminum sign panel (backer)

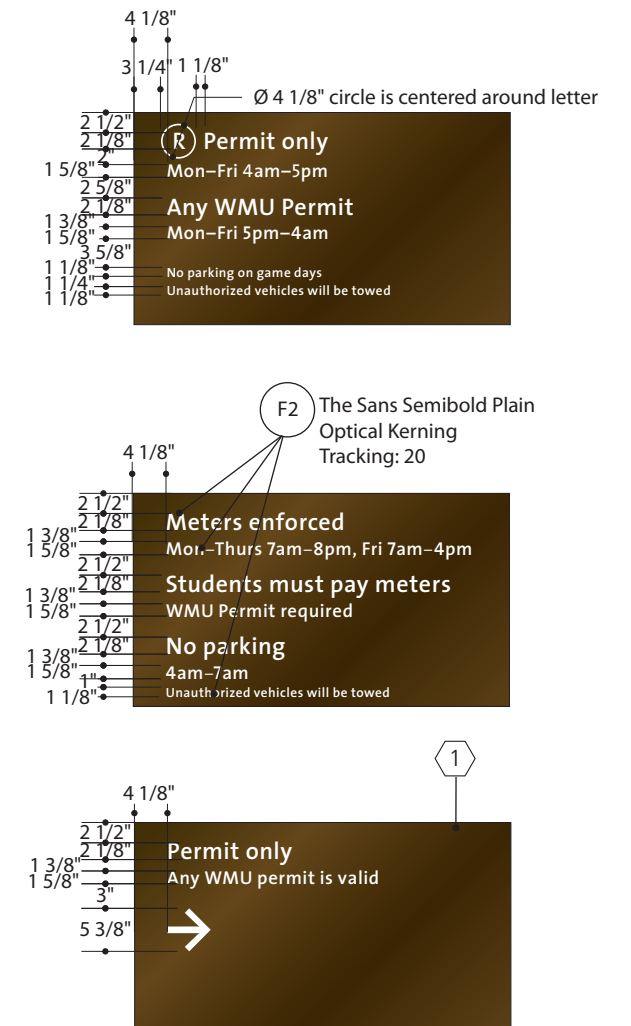
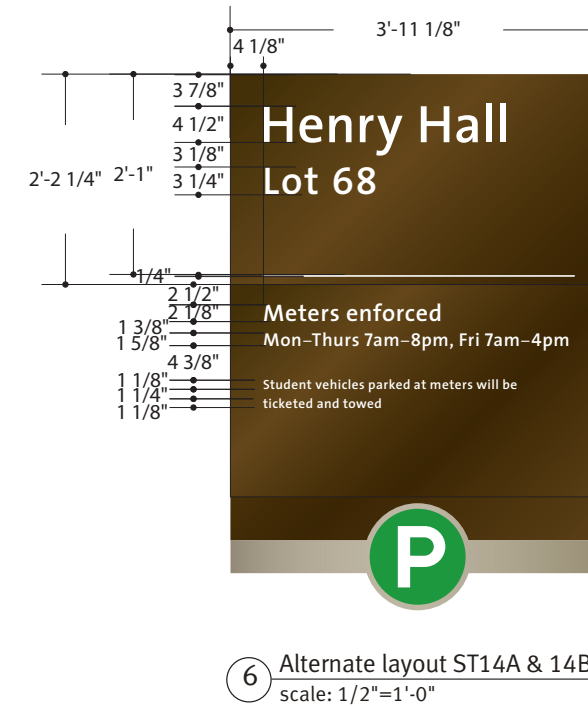
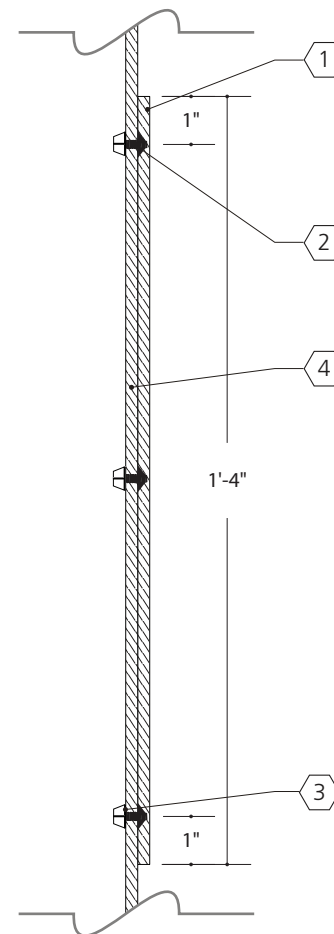

THIS DRAWING REPRESENTS DESIGN INTENT ONLY.
FABRICATOR WILL BE RESPONSIBLE TO VERIFY ALL CONDITIONS IN FIELD PRIOR TO SHOP DRAWINGS.
REFER TO SIGN LOCATION PLAN AND MESSAGE SCHEDULE FOR SIGN TYPES AND LOCATIONS.

Client/Project Western Michigan University Signage Bid Document		Project No. 14WMU249001
Date 12.12.16	Revisions	Scale As noted



2 Plan view ST 14B
scale: 1/2"=1'-0"

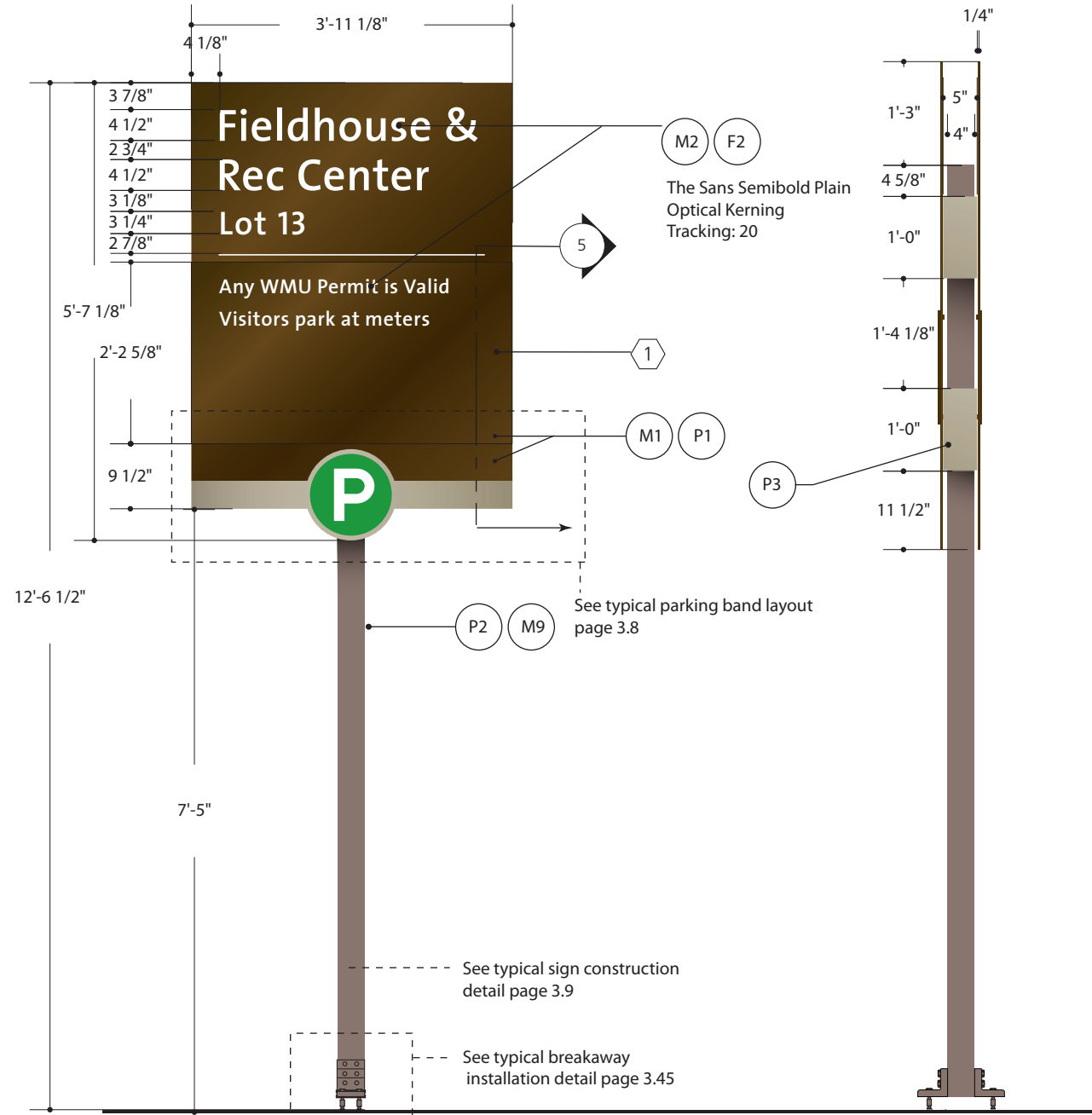

1 Elevation ST14B Parking Regulatory - Large- double-faced
scale: 1/2"=1'-0"

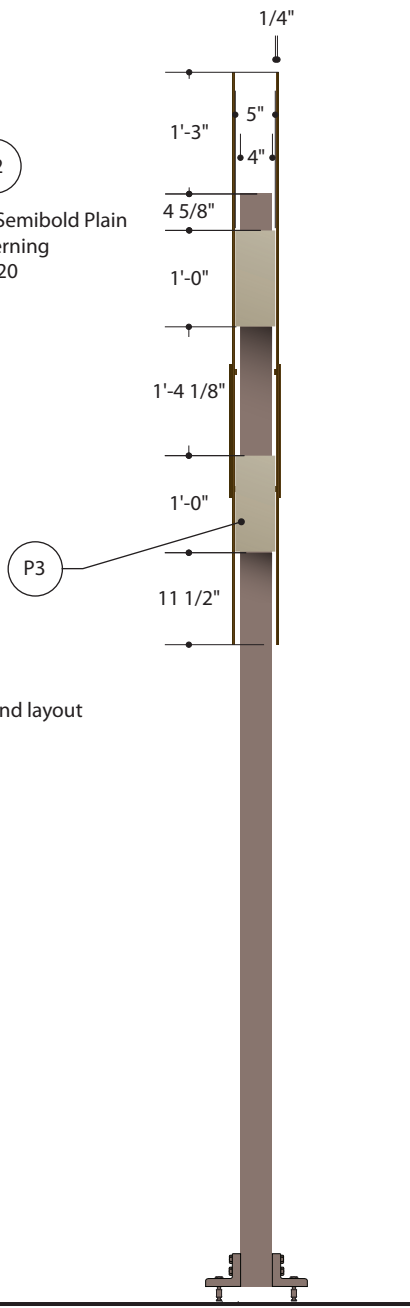

4 Side view ST14B
scale: 1/2"=1'-0"

- 1 1/4" thick removable, painted aluminum panel with applied message
- 2 Fillet-weld threaded stud into back side of aluminum panel
- 3 Threaded stud inserted into threaded holes with tamper-proof nut, fabricator to provide details for review
- 4 1/4" thick painted aluminum sign panel (backer)

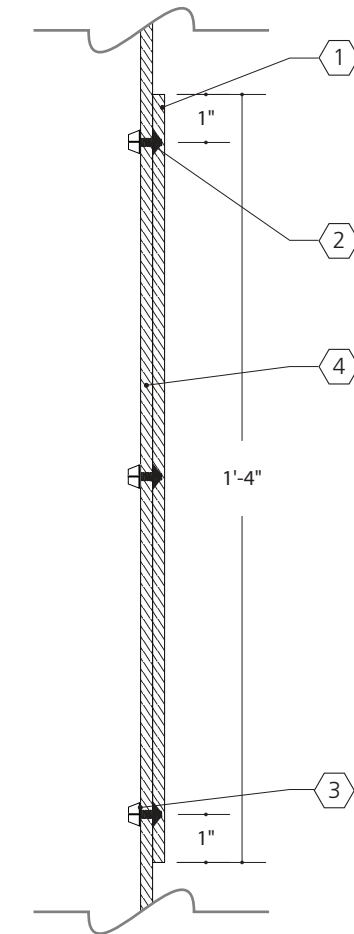

5 Section view, typical
scale: 3"=1'-0"

THIS DRAWING REPRESENTS DESIGN INTENT ONLY. FABRICATOR WILL BE RESPONSIBLE TO VERIFY ALL CONDITIONS IN FIELD PRIOR TO SHOP DRAWINGS. REFER TO SIGN LOCATION PLAN AND MESSAGE SCHEDULE FOR SIGN TYPES AND LOCATIONS.

Client/Project Western Michigan University Signage Bid Document		Project No. 14WMU249001
Date 12.12.16	Revisions	Scale As noted

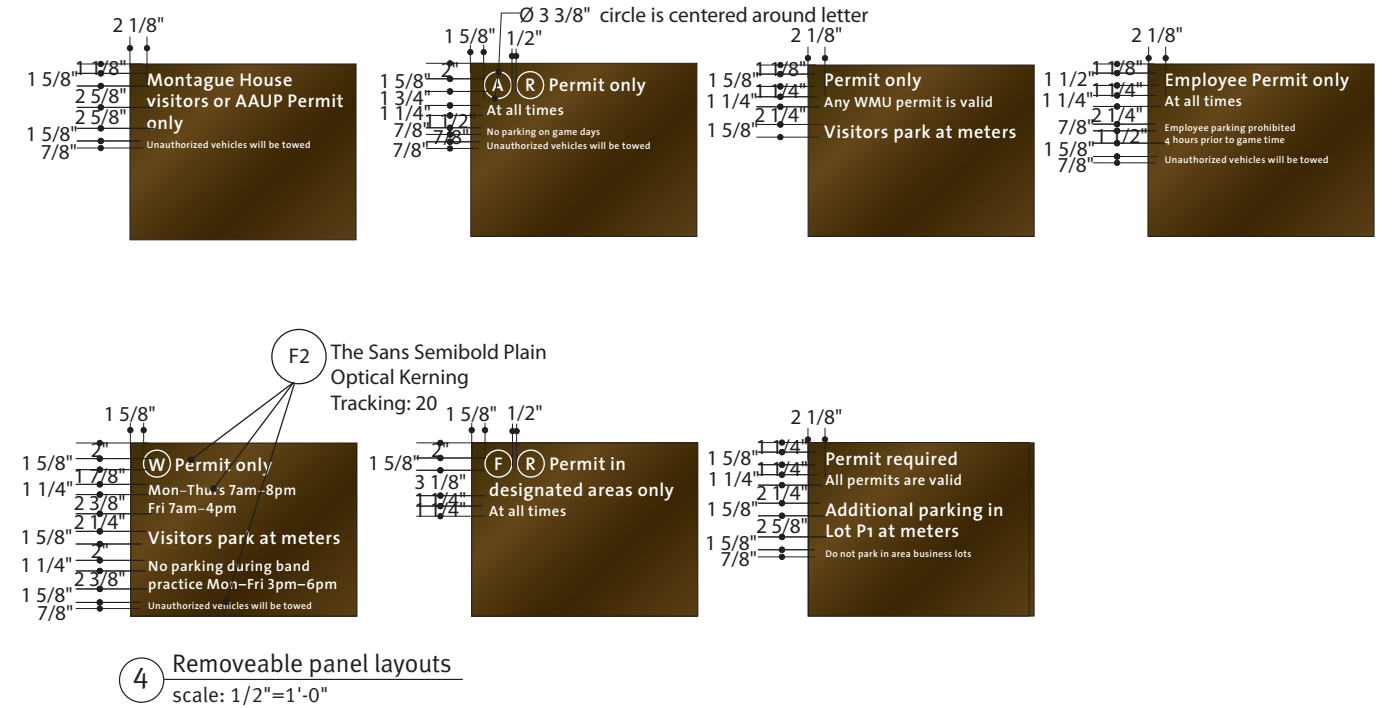
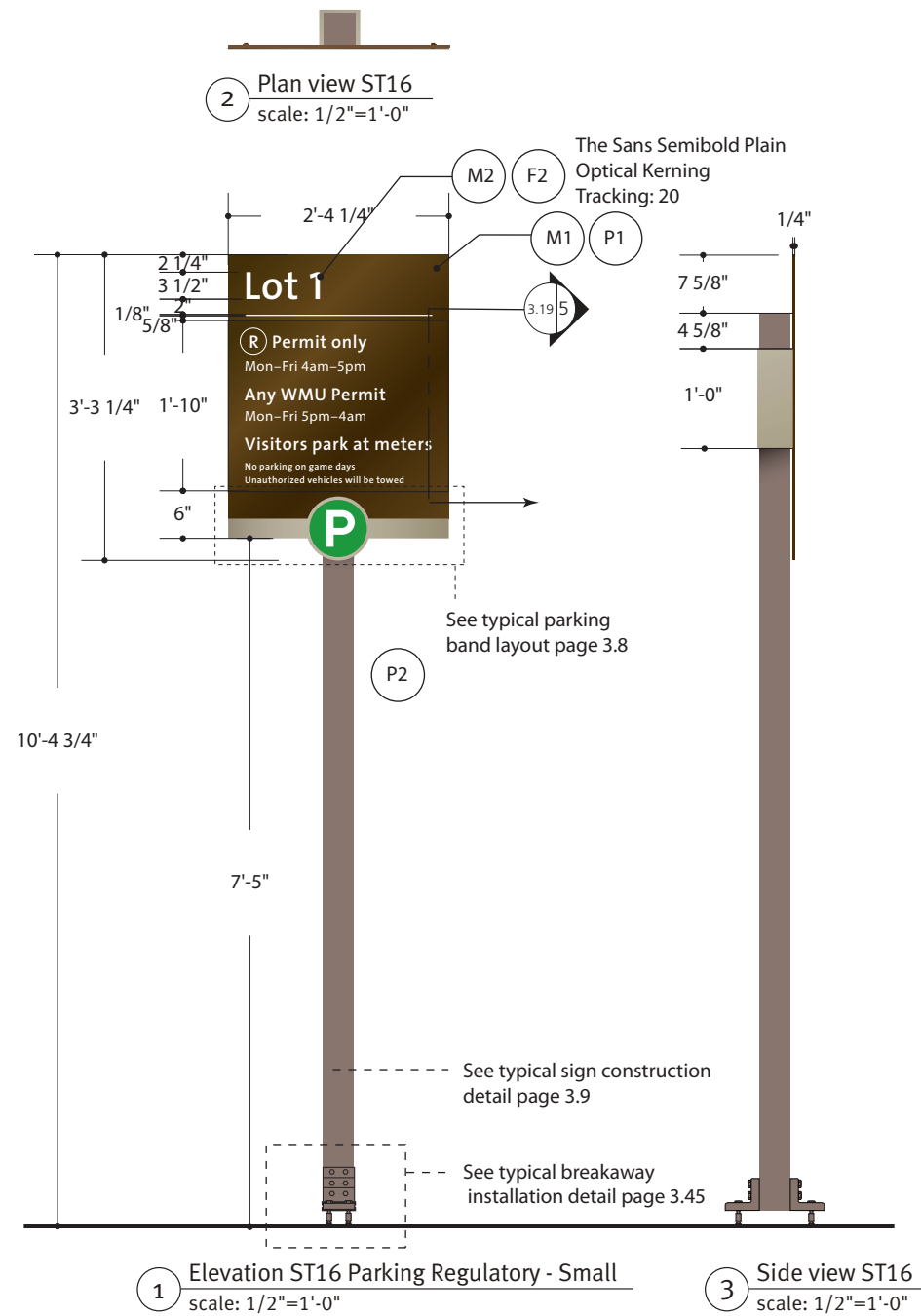

THIS DRAWING REPRESENTS DESIGN INTENT ONLY. FABRICATOR WILL BE RESPONSIBLE TO VERIFY ALL CONDITIONS IN FIELD PRIOR TO SHOP DRAWINGS. REFER TO SIGN LOCATION PLAN AND MESSAGE SCHEDULE FOR SIGN TYPES AND LOCATIONS.

Client/Project Western Michigan University Signage Bid Document		Project No. 14WMU249001
Date 12.12.16	Revisions	Scale As noted



2 Plan view ST20
scale: 1/2"=1'-0"

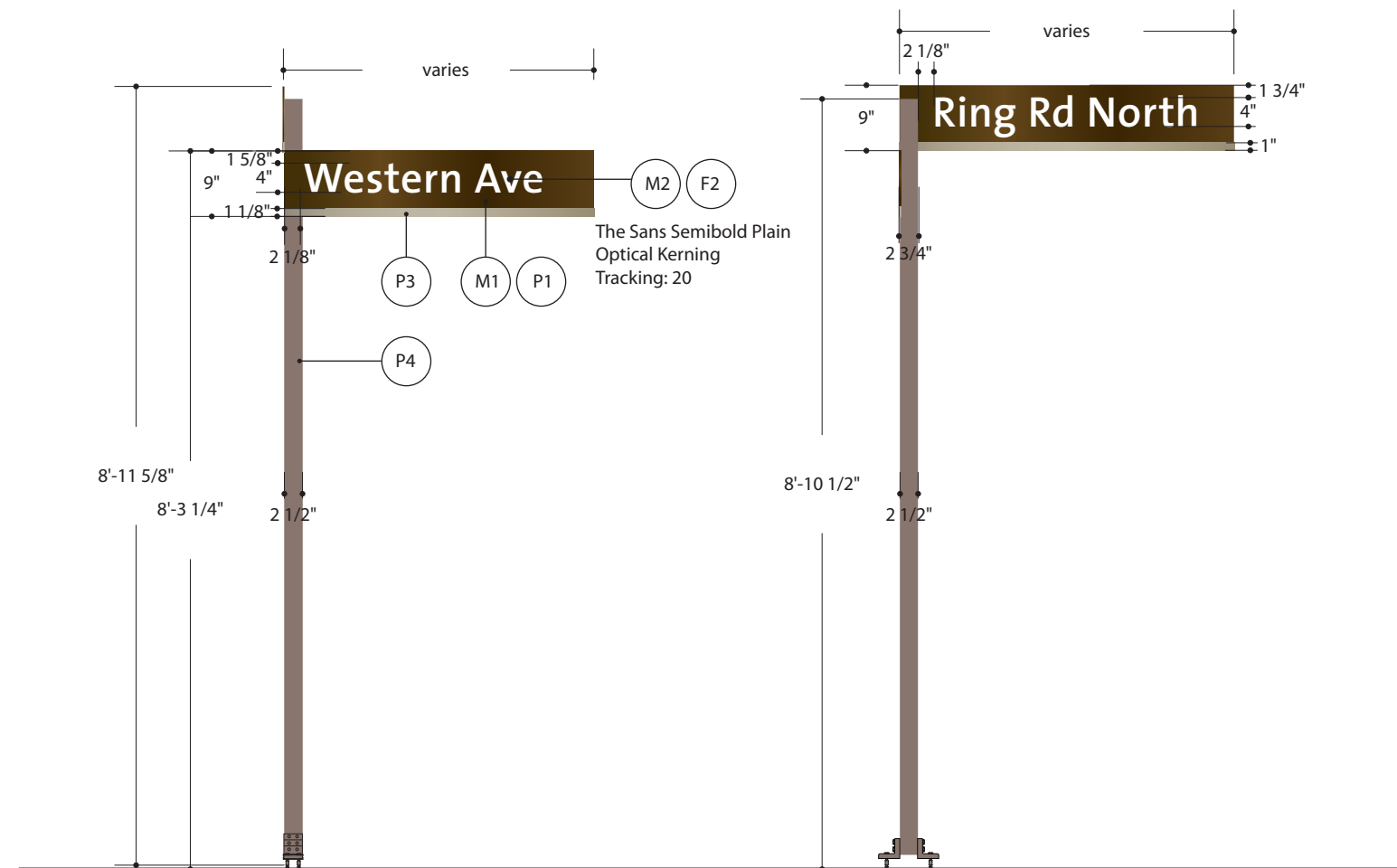

1 Elevation ST20 Street Identification
scale: 1/2"=1'-0"

3 Side view ST20
scale: 1/2"=1'-0"

THIS DRAWING REPRESENTS DESIGN INTENT ONLY.
FABRICATOR WILL BE RESPONSIBLE TO VERIFY ALL
CONDITIONS IN FIELD PRIOR TO SHOP DRAWINGS.
REFER TO SIGN LOCATION PLAN AND MESSAGE
SCHEDULE FOR SIGN TYPES AND LOCATIONS.

Client/Project		Project No.
Western Michigan University Signage Bid Document		14WMU249001
Date	Revisions	Scale
12.12.16		As noted

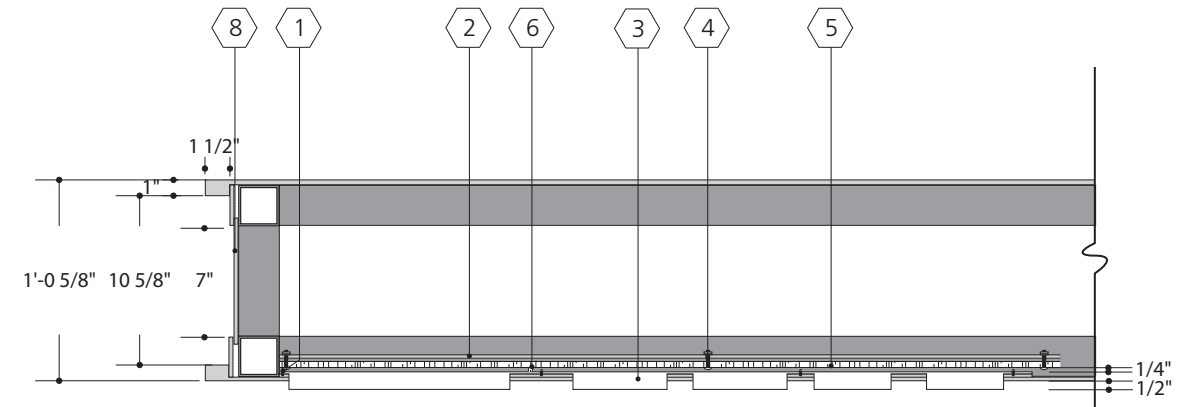

- 1** Threaded stud is fillet welded to the interior side of cabinet, nut secures acrylic to aluminum
- 2** 1/8" thick aluminum plate with welded stud attachment; mechanically fastened to internal structure
- 3** 1" thick router-cut acrylic with routed-out flange and white diffuser film applied to back side.
- 4** DLC Lumisheet is mechanically fastened to aluminum mounting plate
- 5** DLC Lumisheet LED Light Panel connected to approved 60 watt, 12 volt DC exterior rated power supply. Reference page 5.4 for LED and power supply details. Provide details for dimming capabilities. Power supply with a 10 year warranty is recommended, fabricator to provide details for review prior to installation.
- 6** Low voltage wire to remote transformer
- 7** Router-cut, push through acrylic disc with Vivid Green/Pantone 355C 3M translucent film applied
- 8** 1/4" thick aluminum perforated panel, 1/8" Holes on 3/16" Centers, Staggered Pattern, is welded to aluminum side panels

Notes:
Fabricator to ensure that the screens have sufficient ventilation. Fans may need to be installed to ensure the correct ventilation.

Fabricator to determine best location of power switch and electrical connection.

Fabricator to specify how components will be accessed and serviced.

Fabricator must isolate dissimilar materials. All associated hardware must be stainless steel.

THIS DRAWING REPRESENTS DESIGN INTENT ONLY. FABRICATOR WILL BE RESPONSIBLE TO VERIFY ALL CONDITIONS IN FIELD PRIOR TO SHOP DRAWINGS. REFER TO SIGN LOCATION PLAN AND MESSAGE SCHEDULE FOR SIGN TYPES AND LOCATIONS.

Client/Project Western Michigan University Signage Bid Document		Project No. 14WMU249001
Date 12.12.16	Revisions	Scale As noted

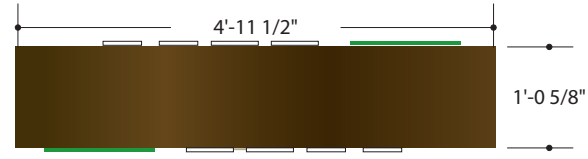

2 Plan view
scale: 1/2" = 1'-0"

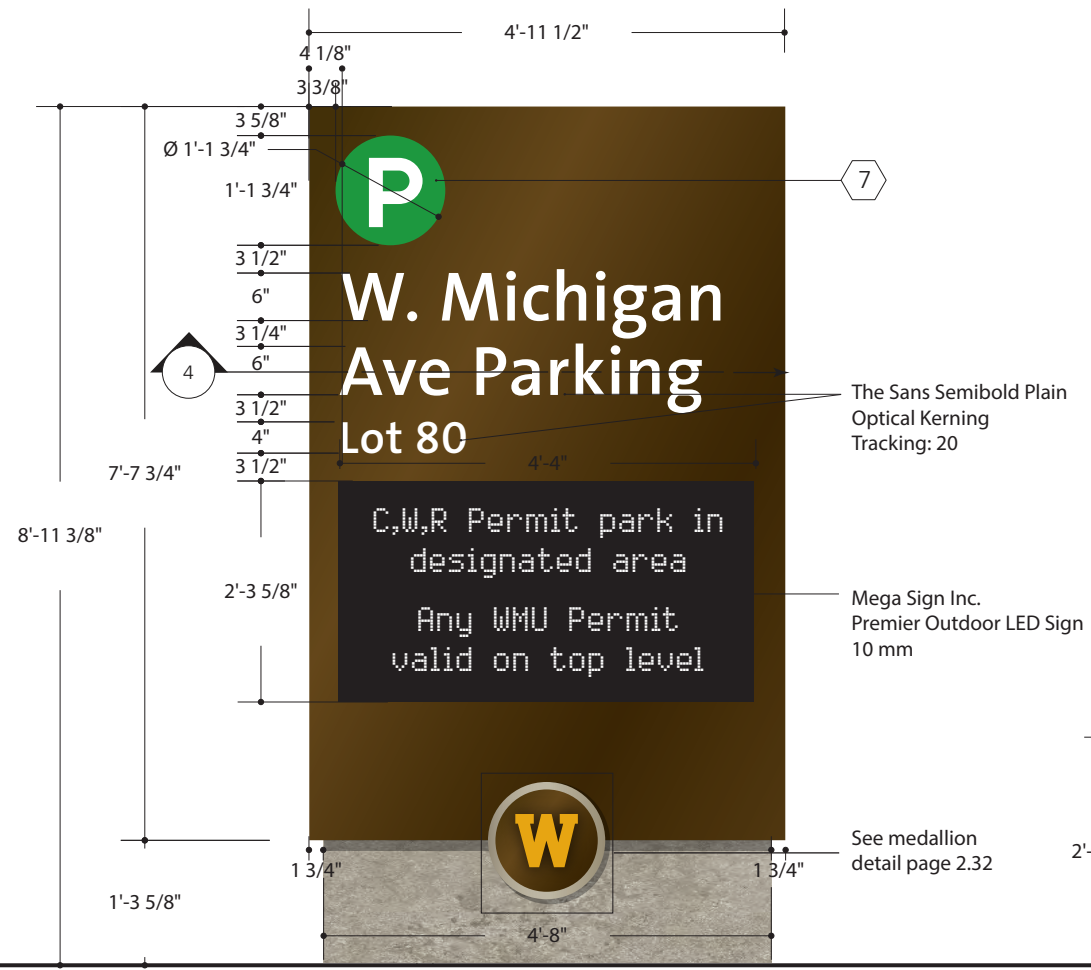

1 Elevation – ST 17B Parking Garage ID - double-faced
scale: 1/2" = 1'-0"

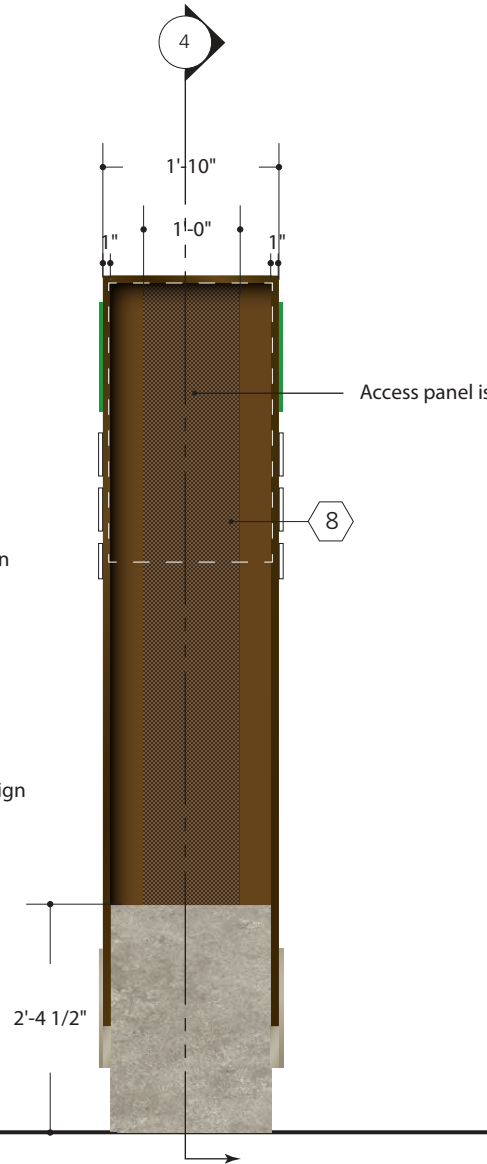

3 Side view
scale: 1/2" = 1'-0"

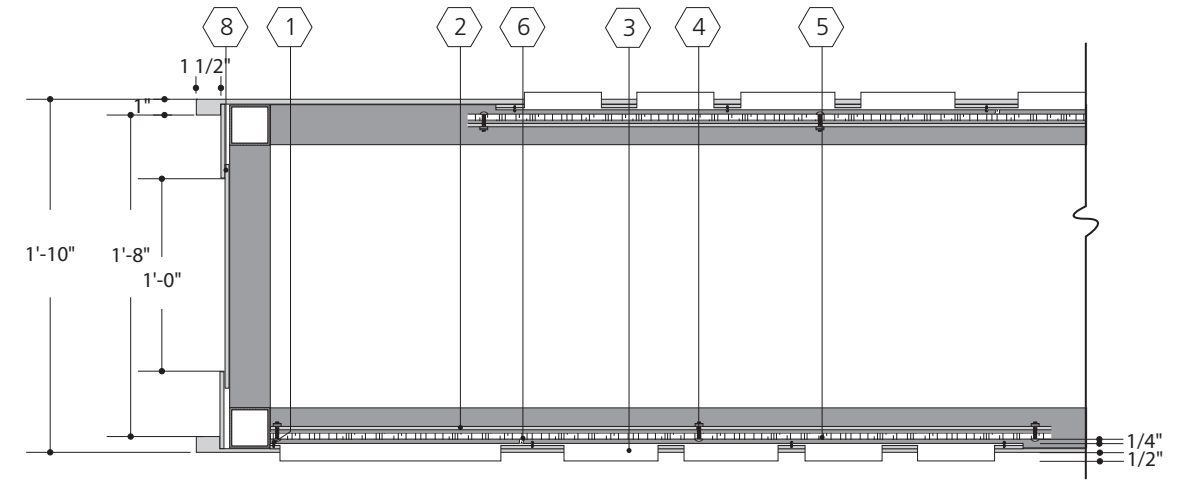

4 Section view
scale: 1" = 1'-0"

Access panel is located on sign side

- 1 Threaded stud is fillet welded to the interior side of cabinet, nut secures acrylic to aluminum
- 2 1/8" thick aluminum plate with welded stud attachment; mechanically fastened to internal structure
- 3 1" thick router-cut acrylic with routed-out flange and white diffuser film applied to back side.
- 4 DLC Lumisheet is mechanically fastened to aluminum mounting plate
- 5 DLC Lumisheet LED Light Panel connected to approved 60 watt, 12 volt DC exterior rated power supply. Reference page 5.4 for LED and power supply details. Provide details for dimming capabilities. Power supply with a 10 year warranty is recommended, fabricator to provide details for review prior to installation.
- 6 Low voltage wire to remote transformer
- 7 Router-cut, push through acrylic disc with Vivid Green/Pantone 355C 3M translucent film applied
- 8 1/4" thick aluminum perforated panel, 1/8" Holes on 3/16" Centers, Staggered Pattern, is welded to aluminum side panels

Client/Project Western Michigan University Signage Bid Document		Project No. 14WMU249001
Date 12.12.16	Revisions	Scale As noted

THIS DRAWING REPRESENTS DESIGN INTENT ONLY. FABRICATOR WILL BE RESPONSIBLE TO VERIFY ALL CONDITIONS IN FIELD PRIOR TO SHOP DRAWINGS. REFER TO SIGN LOCATION PLAN AND MESSAGE SCHEDULE FOR SIGN TYPES AND LOCATIONS.

ST 26 Building directory/map

- 1 1/4" thick aluminum "frame" panel, routed out to receive 1/8" map panel. Z-clips anchored to the back of the panel
- 2 Map is vinyl-wrapped 1/8" thick panel set in behind sign "frame" panel. Map and directory provided as artwork by WMU Office of University Relations.
- 3 1/4" thick aluminum panel attached to frame
- 4 Side enclosures are welded to internal structure
- 5 Top of sign is mechanically fastened to secure sign panels

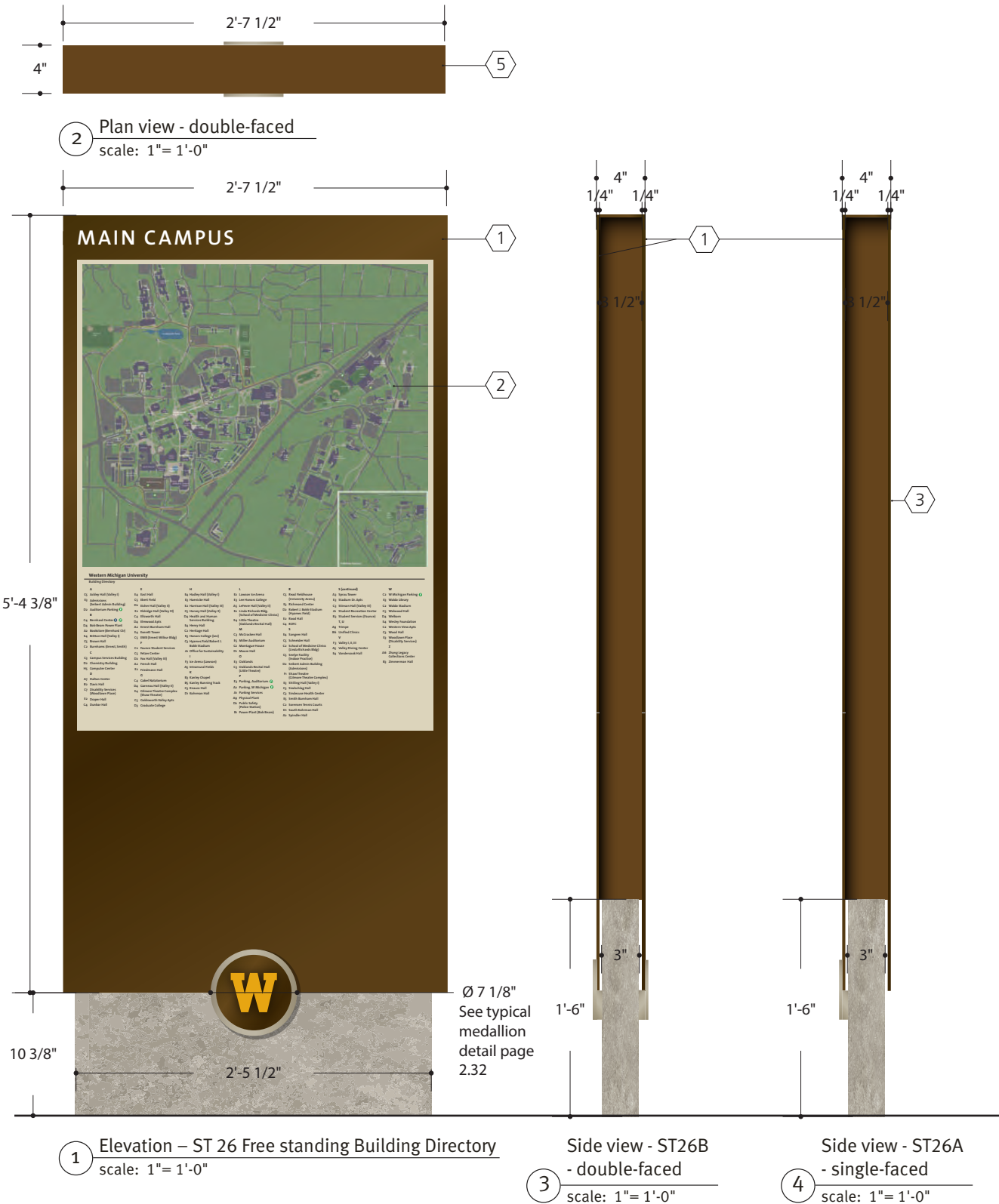

Note:
Fabricator must isolate dissimilar materials.
All associated hardware must be stainless steel.
Provide (2) 3/4" conduits for future power & data.
Stub through sign base/footing.

THIS DRAWING REPRESENTS DESIGN INTENT ONLY.
FABRICATOR WILL BE RESPONSIBLE TO VERIFY ALL CONDITIONS IN FIELD PRIOR TO SHOP DRAWINGS.
REFER TO SIGN LOCATION PLAN AND MESSAGE SCHEDULE FOR SIGN TYPES AND LOCATIONS.

Client/Project Western Michigan University Signage Bid Document		Project No. 14WMU249001
Date 12.12.16	Revisions	Scale As noted

- 1 1/4" thick aluminum "frame" panel, routed out to receive 1/8" map panel. Z-clips anchored to the back of the panel
- 2 Internal structure is 3" square extruded steel pole with 1 1/2" square extruded cross-bars.
- 3 1/8" thick aluminum sheet, welded to internal structure, with holes to accept z-clips.
- 4 Map is vinyl-wrapped 1/8" thick panel set in behind sign "frame" panel. Map and directory provided as artwork by WMU Office of University Relations.
- 5 1/4" thick aluminum panel attached to frame
- 6 Side enclosures are welded to internal structure
- 7 Top of sign is mechanically fastened to secure sign panels
- 8 Medallion is welded to sign panel
- 9 2' 5" x 3 1/2" weld plate
- 10 Reinforced concrete footer; to be engineered by fabricator

Note:
Fabricator must isolate dissimilar materials.
All associated hardware must be stainless steel.
Provide (2) 3/4" conduits for future power & data.
Stub through sign base/footering.



1 Detail: Map panel
scale: 1" = 1'-0"

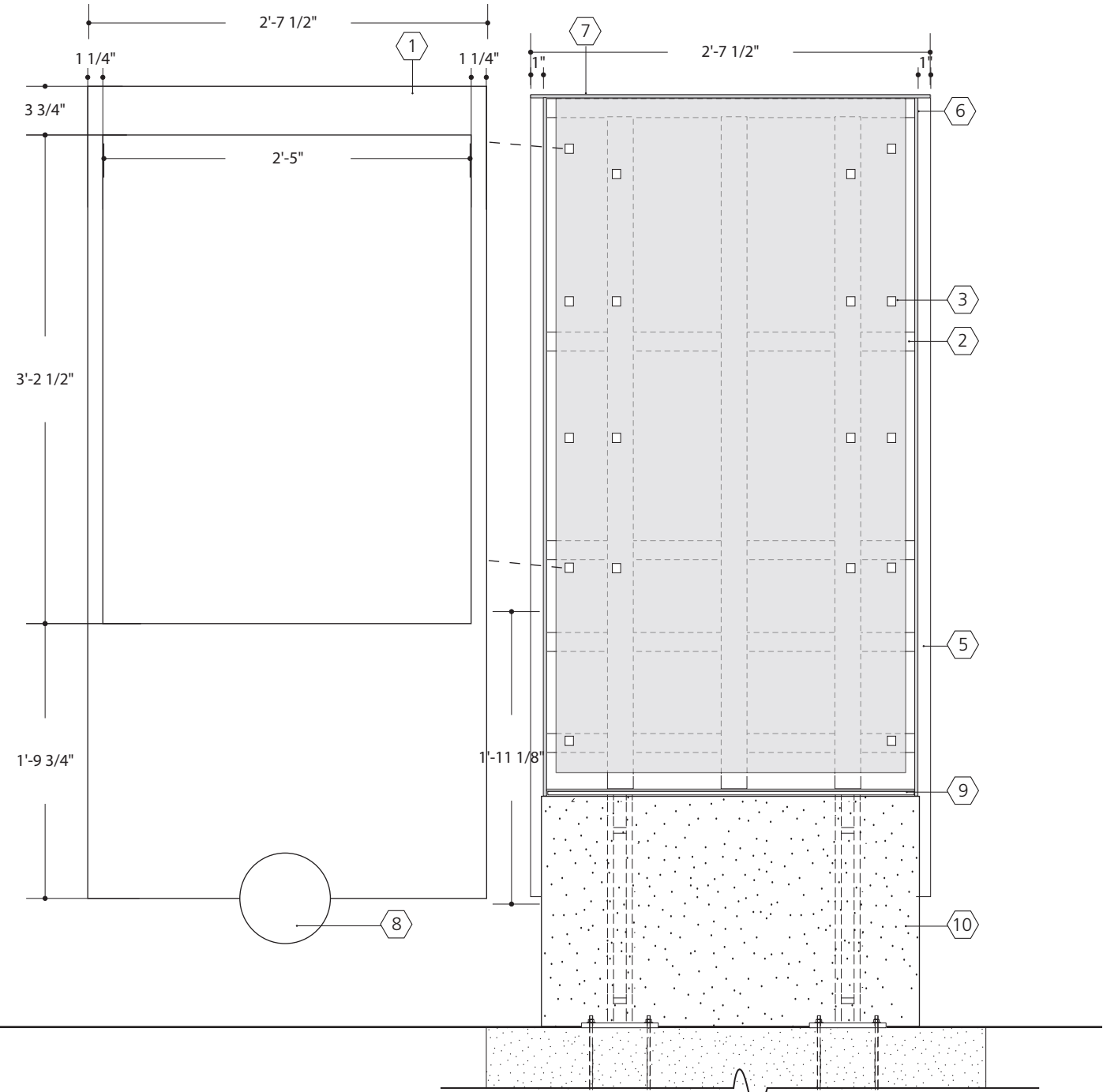

2 Construction detail elevation
scale: 1" = 1'-0"

THIS DRAWING REPRESENTS DESIGN INTENT ONLY.
FABRICATOR WILL BE RESPONSIBLE TO VERIFY ALL
CONDITIONS IN FIELD PRIOR TO SHOP DRAWINGS.
REFER TO SIGN LOCATION PLAN AND MESSAGE
SCHEDULE FOR SIGN TYPES AND LOCATIONS.

Client/Project Western Michigan University Signage Bid Document		Project No. 14WMU249001
Date 12.12.16	Revisions	Scale As noted

ST 27 Pedestrian Directional with map

DRAWINGS

3.30



1 Layout – Map panel – ST 27 Ped Directional w/ map scale: 3"= 1'-0"

Note: Map and directory provided as artwork by WMU Office of University Relations.

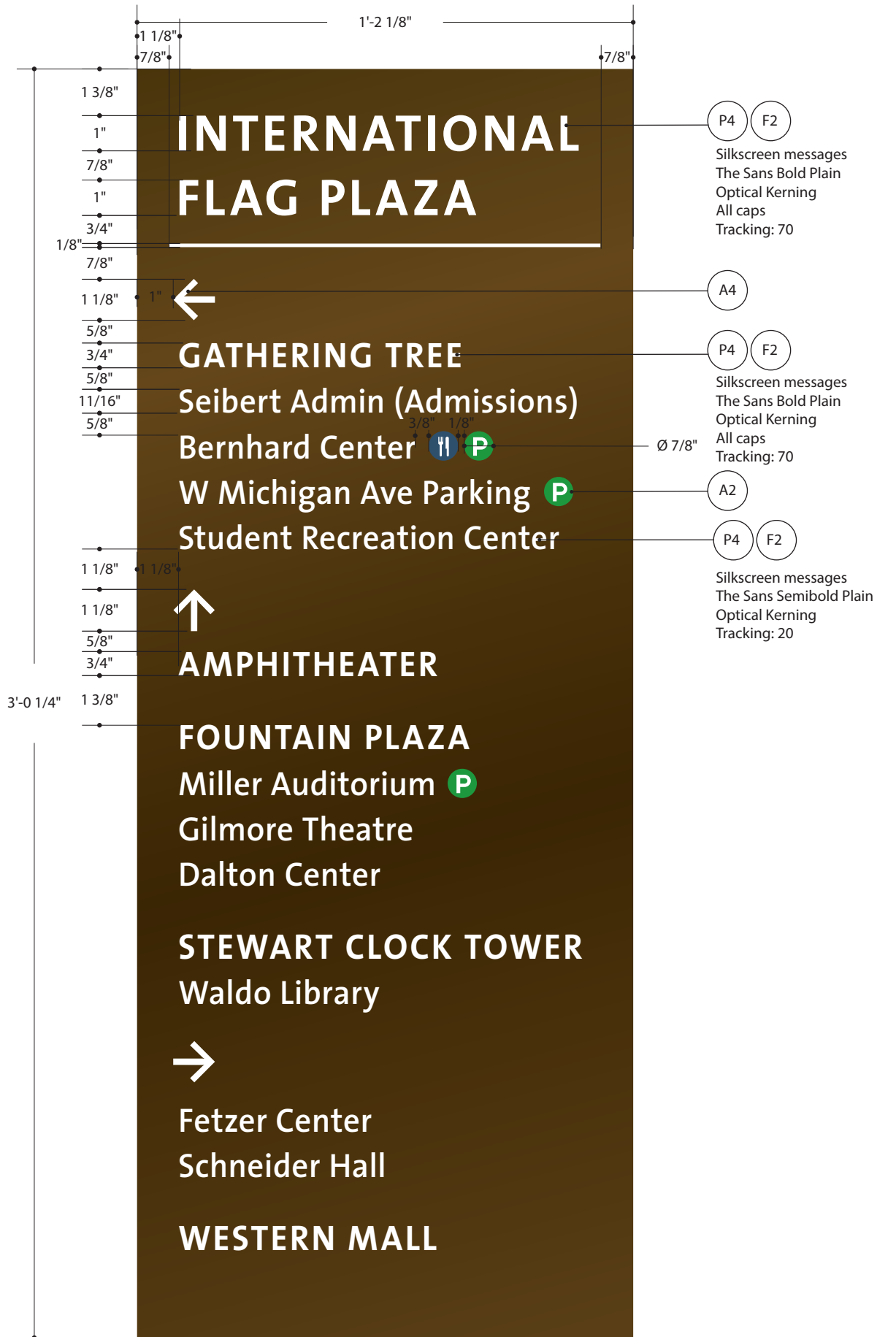

2 Layout – Top panel – ST 27 Ped Directional w/ map scale: 3"= 1'-0"

THIS DRAWING REPRESENTS DESIGN INTENT ONLY. FABRICATOR WILL BE RESPONSIBLE TO VERIFY ALL CONDITIONS IN FIELD PRIOR TO SHOP DRAWINGS. REFER TO SIGN LOCATION PLAN AND MESSAGE SCHEDULE FOR SIGN TYPES AND LOCATIONS.

Client/Project Western Michigan University Signage Bid Document	Project No. 14WMU249001
Date 12.12.16	Revisions
Scale As noted	

ST 27 Pedestrian Directional with map



Plan view - Pedestrian directional pad - corner condition

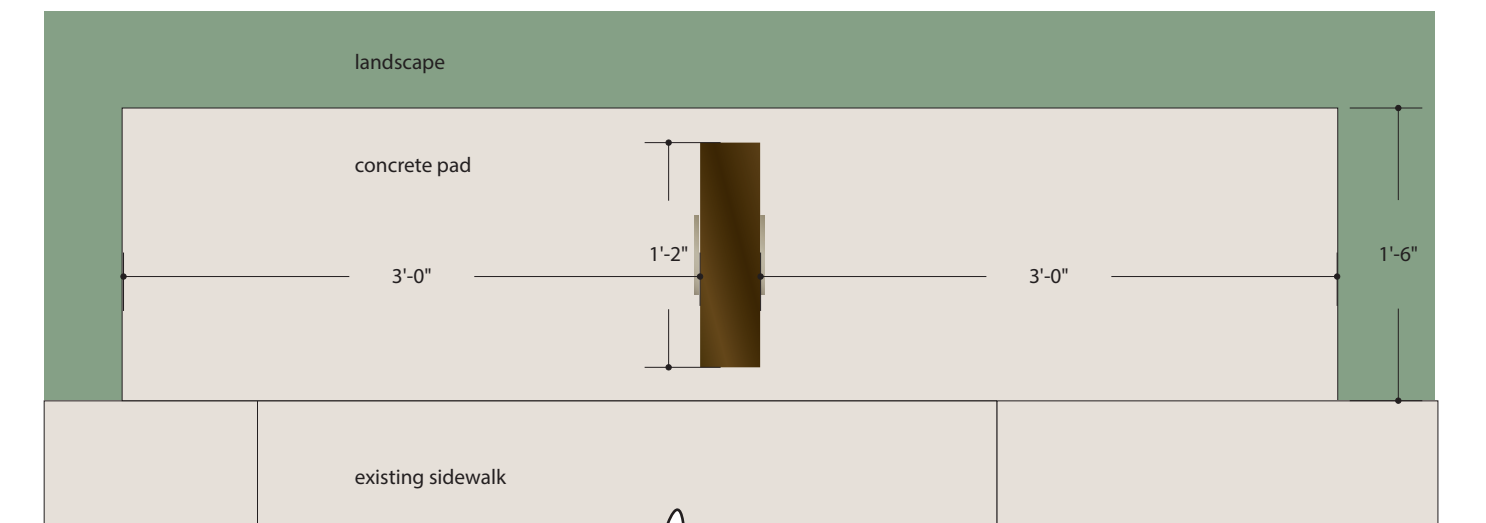

Plan view - Pedestrian directional pad - single path condition



ST 27 In situ

THIS DRAWING REPRESENTS DESIGN INTENT ONLY. FABRICATOR WILL BE RESPONSIBLE TO VERIFY ALL CONDITIONS IN FIELD PRIOR TO SHOP DRAWINGS. REFER TO SIGN LOCATION PLAN AND MESSAGE SCHEDULE FOR SIGN TYPES AND LOCATIONS.

Client/Project		Project No.
Western Michigan University Signage Bid Document		14WMU249001
Date	Revisions	Scale
12.12.16		As noted

ST 29 - Pedestrian Directional



2 Plan view - double-faced
scale: 1"=1'-0"

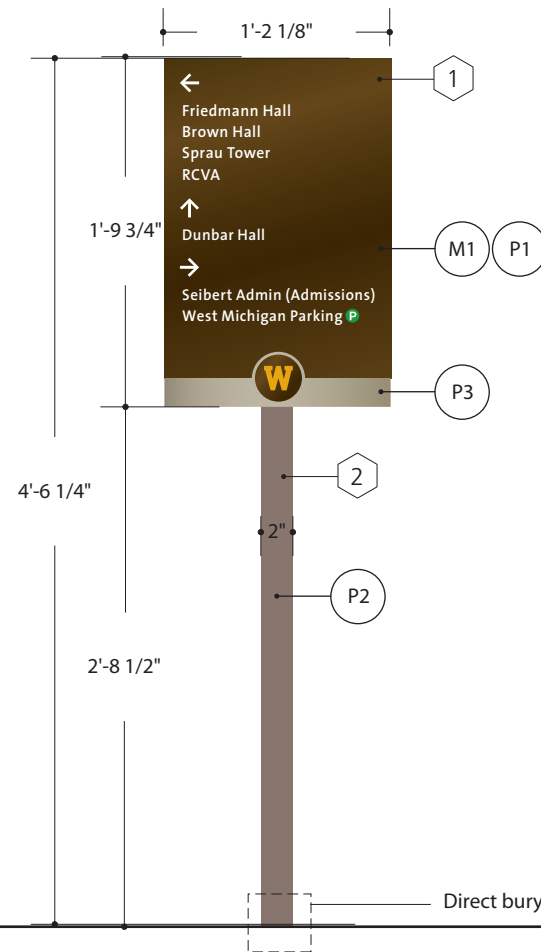

1 Elevation – ST 29 Pedestrian directional
scale: 1"=1'-0"



5 Plan view - single-faced
scale: 1"=1'-0"

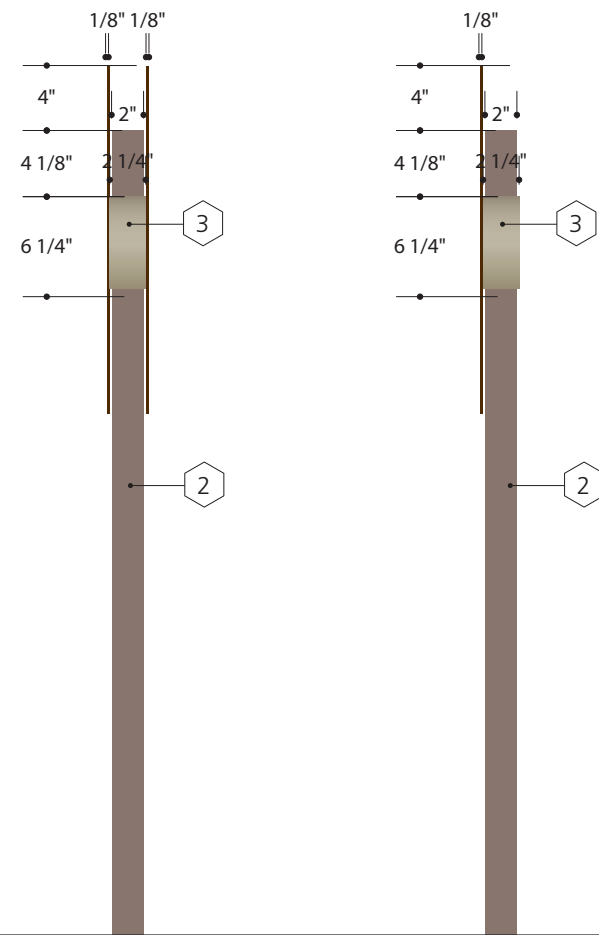

3 Plan view - double-faced
scale: 1"=1'-0"

4 Side view - single-faced
scale: 1"=1'-0"

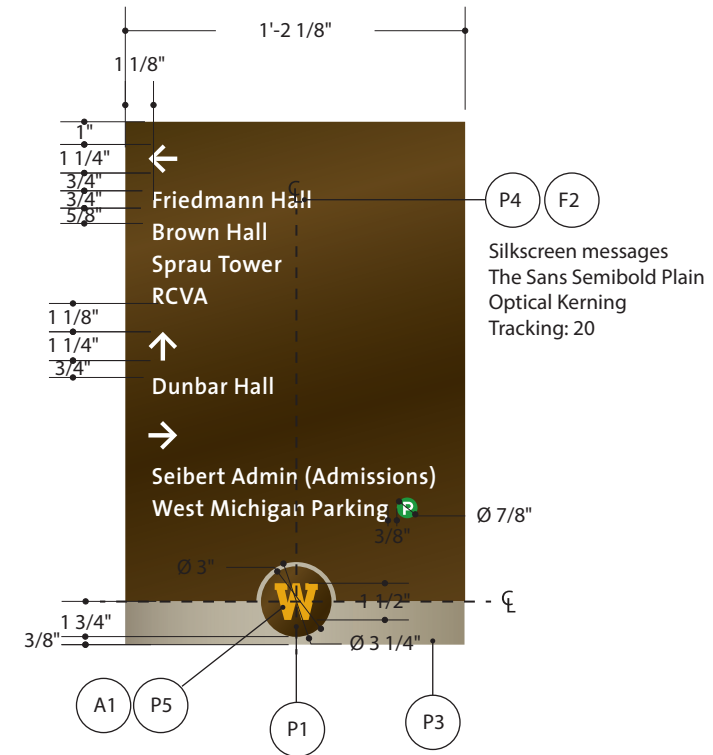

6 Layout
scale: 1 1/2"=1'-0"

- 1 1/8" thick aluminum sign panel mechanically fastened to cuff
- 2" square aluminum sign post
- 2 1/4" square aluminum extruded sign cuff. See page 3.9 for typical detail.

THIS DRAWING REPRESENTS DESIGN INTENT ONLY. FABRICATOR WILL BE RESPONSIBLE TO VERIFY ALL CONDITIONS IN FIELD PRIOR TO SHOP DRAWINGS. REFER TO SIGN LOCATION PLAN AND MESSAGE SCHEDULE FOR SIGN TYPES AND LOCATIONS.

Client/Project Western Michigan University Signage Bid Document		Project No. 14WMU249001
Date 12.12.16	Revisions	Scale As noted

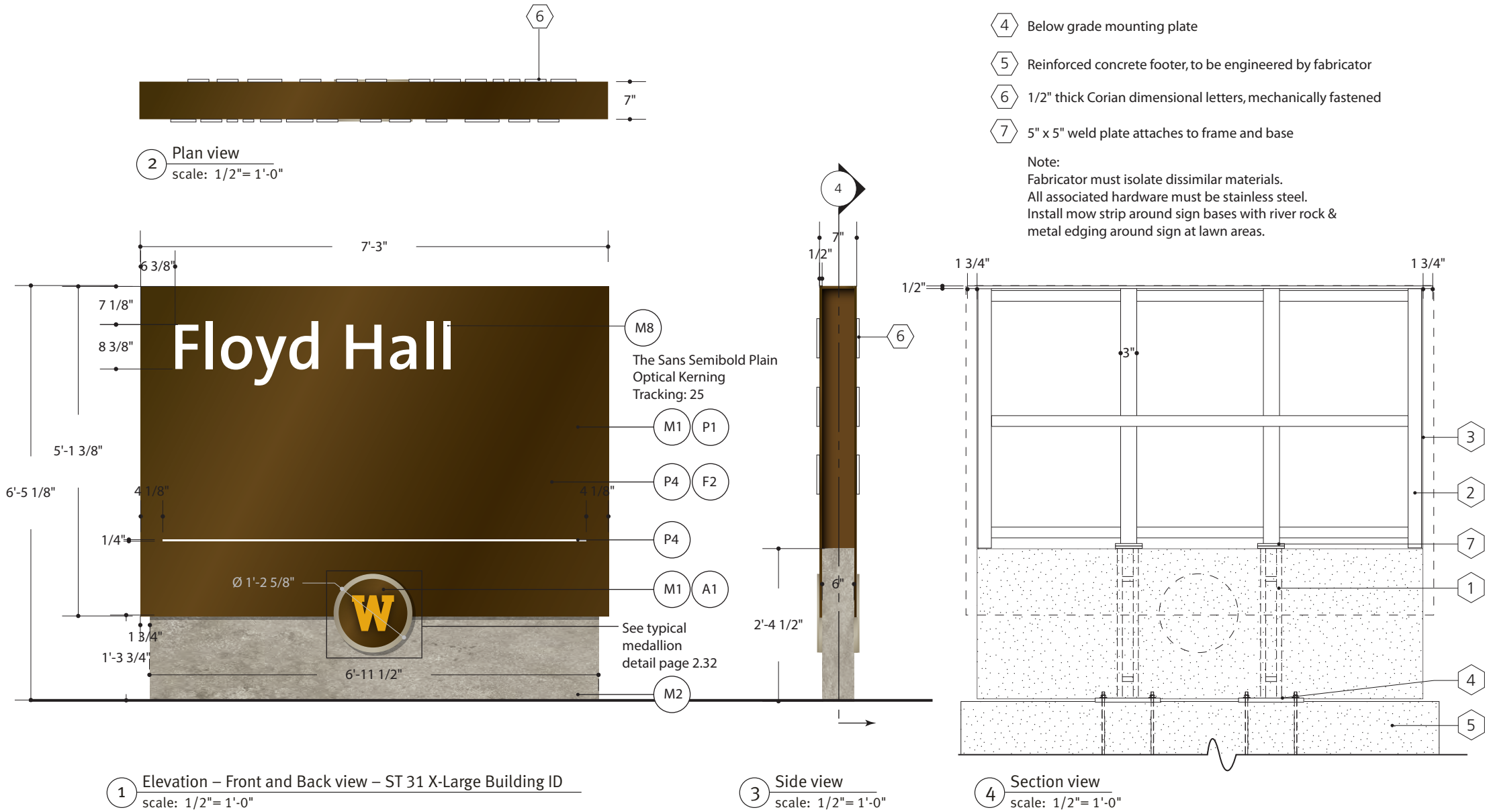

THIS DRAWING REPRESENTS DESIGN INTENT ONLY.
FABRICATOR WILL BE RESPONSIBLE TO VERIFY ALL
CONDITIONS IN FIELD PRIOR TO SHOP DRAWINGS.
REFER TO SIGN LOCATION PLAN AND MESSAGE
SCHEDULE FOR SIGN TYPES AND LOCATIONS.

Client/Project		Project No.
Western Michigan University Signage Bid Document		14WMU249001
Date	Revisions	Scale
12.12.16		As noted

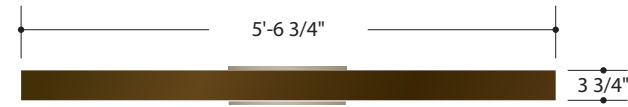

Note: Install mow strip around sign bases with river rock & metal edging around sign at lawn areas.

2 Plan view
scale: 1/2" = 1'-0"

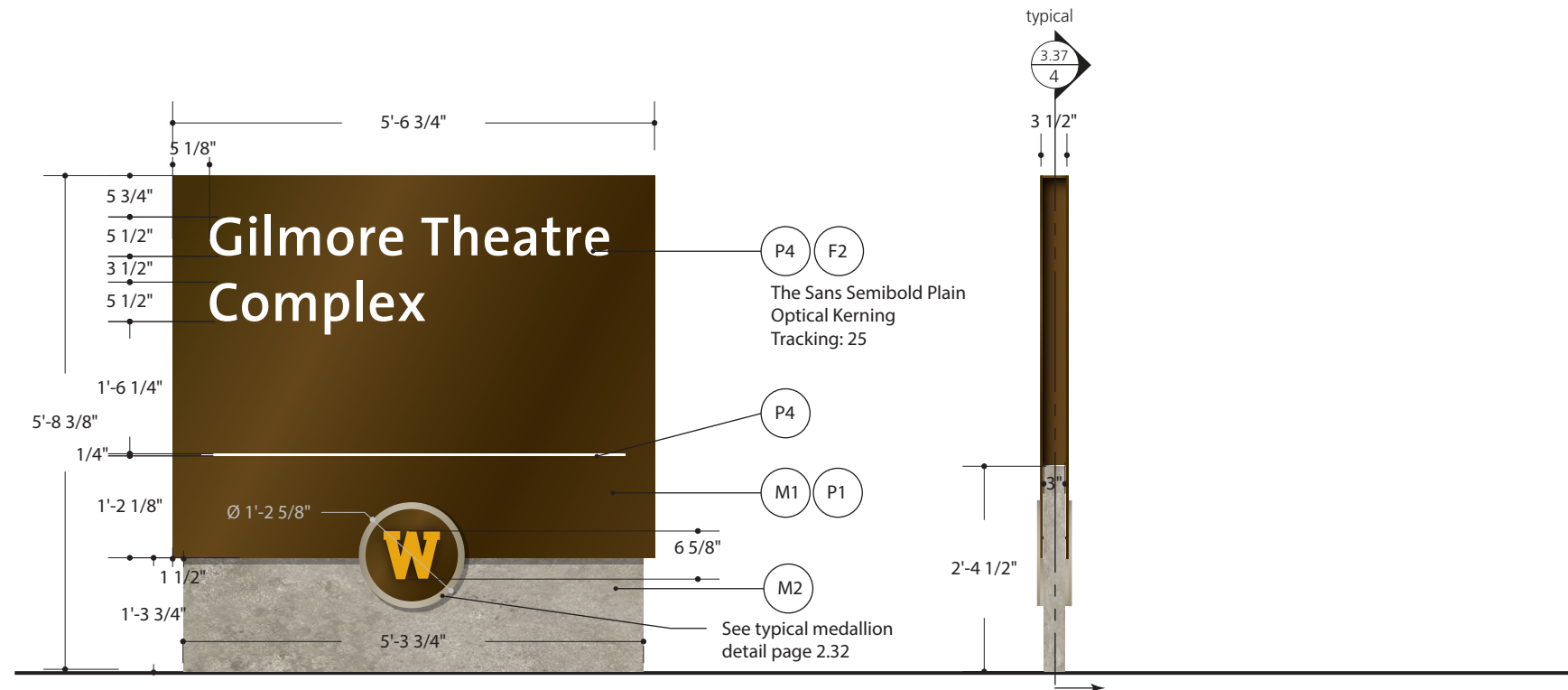

1 Elevation – Front and Back view – ST 32 Building ID - Large
scale: 1/2" = 1'-0"

3 Side view
scale: 1/2" = 1'-0"

THIS DRAWING REPRESENTS DESIGN INTENT ONLY. FABRICATOR WILL BE RESPONSIBLE TO VERIFY ALL CONDITIONS IN FIELD PRIOR TO SHOP DRAWINGS. REFER TO SIGN LOCATION PLAN AND MESSAGE SCHEDULE FOR SIGN TYPES AND LOCATIONS.

Client/Project Western Michigan University Signage Bid Document		Project No. 14WMU249001
Date 12.12.16	Revisions	Scale As noted



2 Plan view
scale: 1/2" = 1'-0"

- 1 1/8" thick aluminum panel attached to frame
- 2 Steel sign frame
- 3 Aluminum side panels welded to frame
- 4 Below grade mounting plate
- 5 Reinforced concrete footer, to be engineered by fabricator
- 6 Daktronics Galaxy GS6 15.85 MM Outdoor LED sign, double-sided
- 7 Precast concrete with 1" rod weldment
- 8 5" x 5" weld plate attaches to frame and base
- 9 1" thick router-cut acrylic with routed-out flange and white diffuser film applied to back side.

Notes:
Fabricator to ensure that the screens have sufficient ventilation. Fans may need to be installed to ensure the correct ventilation.

Fabricator to determine best location of power switch and electrical connection.

Fabricator to specify how components will be accessed and serviced.

Fabricator must isolate dissimilar materials. All associated hardware must be stainless steel.

Install mow strip around sign bases with river rock & metal edging around sign at lawn areas.

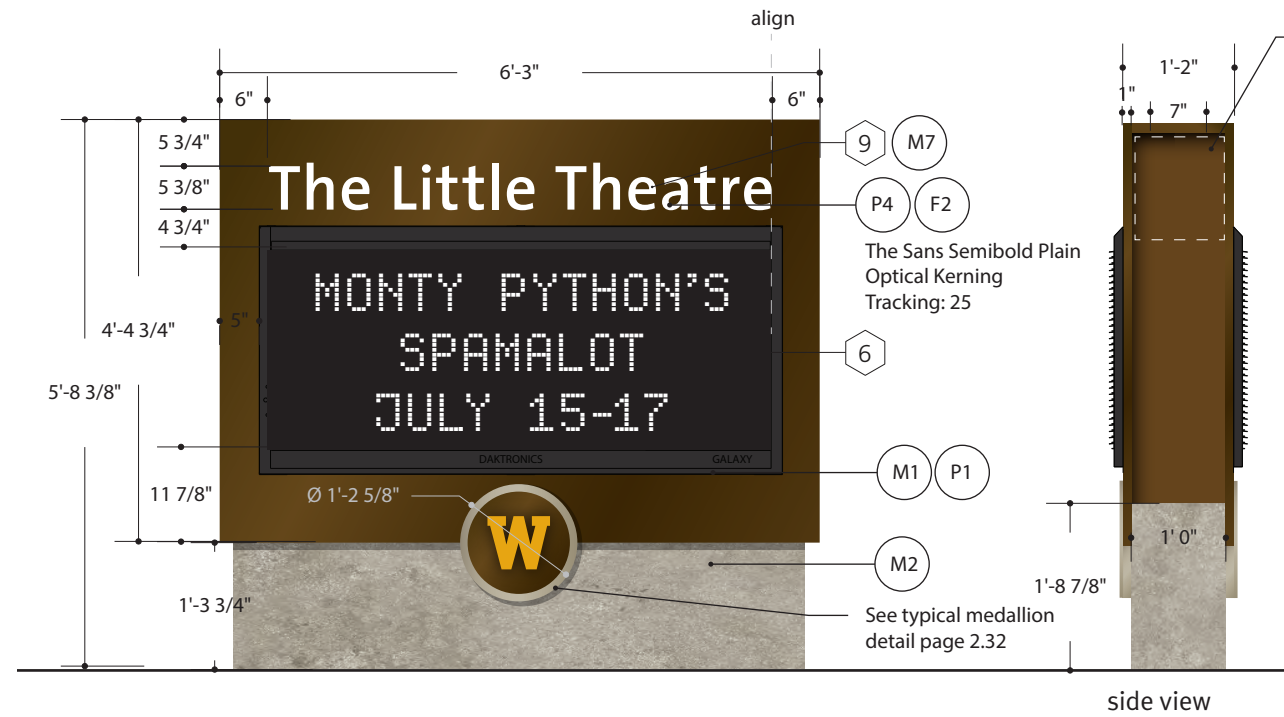

1 Elevation – Front view – ST 33 Building ID - Large w/ LED
scale: 1/2" = 1'-0"

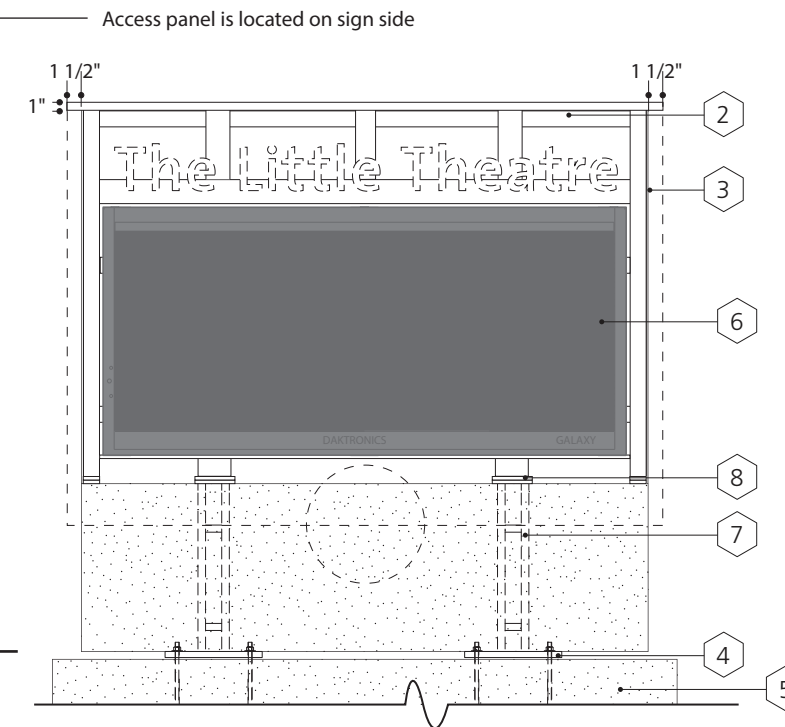

4 Section view
scale: 1/2" = 1'-0"

THIS DRAWING REPRESENTS DESIGN INTENT ONLY. FABRICATOR WILL BE RESPONSIBLE TO VERIFY ALL CONDITIONS IN FIELD PRIOR TO SHOP DRAWINGS. REFER TO SIGN LOCATION PLAN AND MESSAGE SCHEDULE FOR SIGN TYPES AND LOCATIONS.

Client/Project Western Michigan University Signage Bid Document		Project No. 14WMU249001
Date 12.12.16	Revisions	Scale As noted

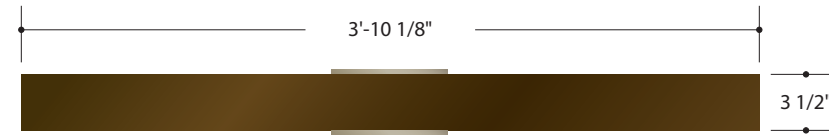

2 Plan view
scale: 1"= 1'-0"

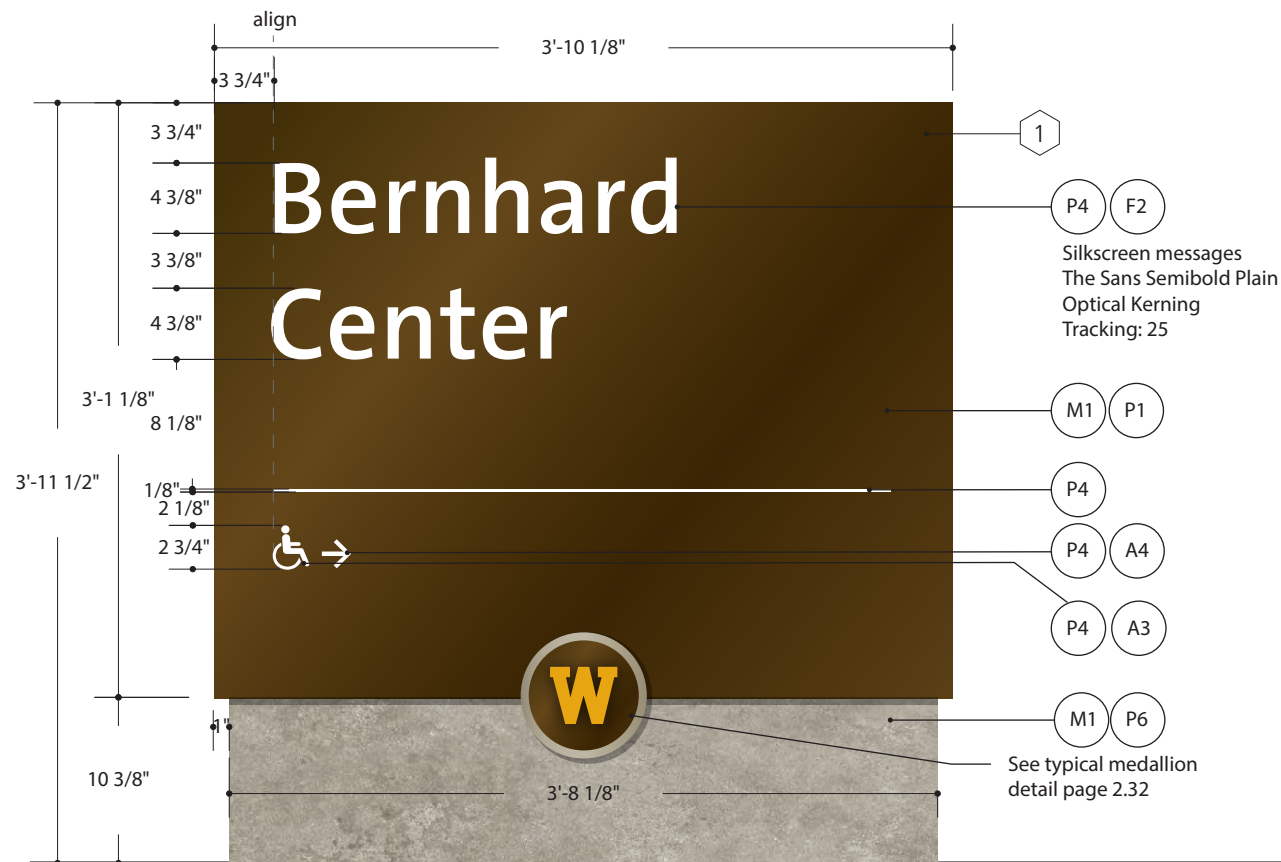

1 Elevation – Front and Back view – ST 34 Building ID - Medium
scale: 1"= 1'-0"



3 Side view
scale: 1"= 1'-0"

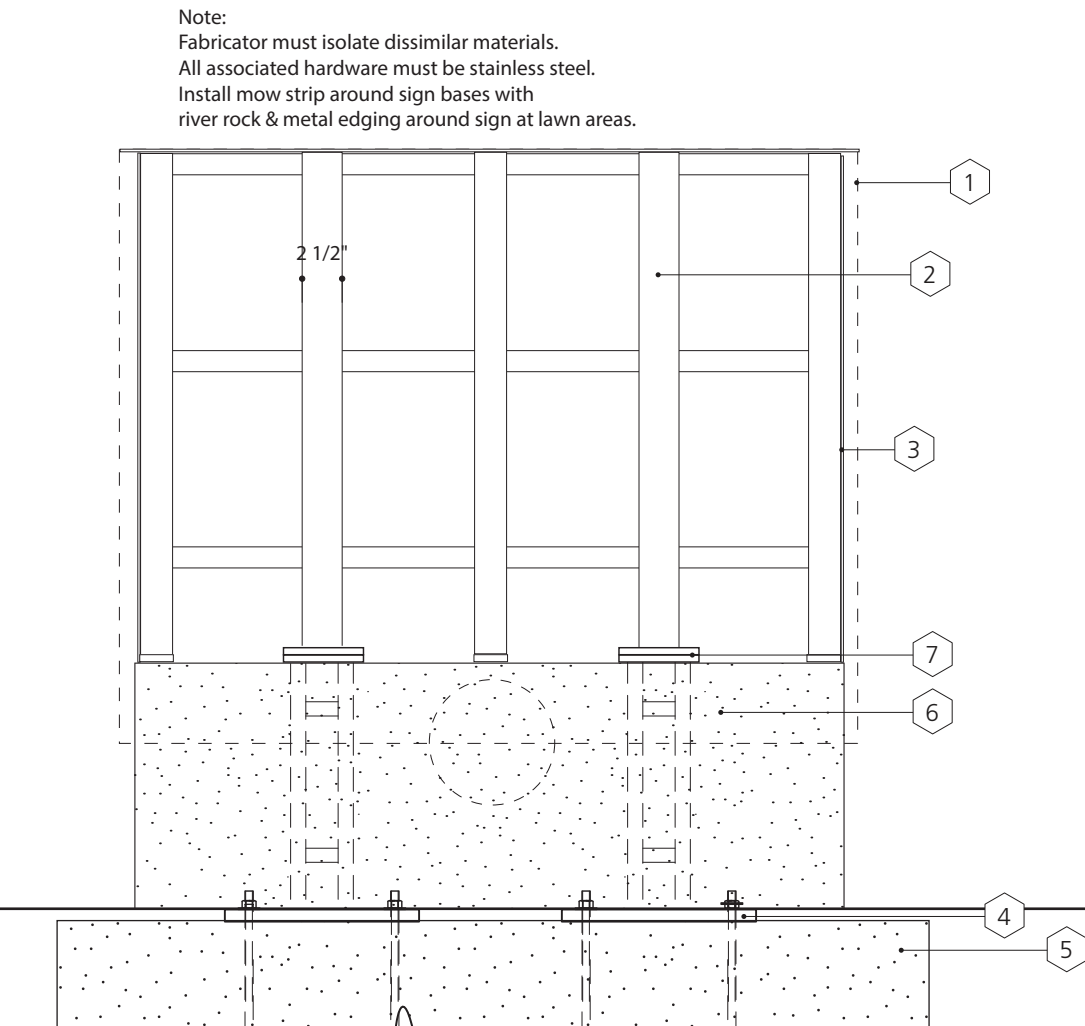

4 Section view, typical
scale: 1"= 1'-0"

- 1 1/8" thick aluminum panel attached to frame
- 2 Steel sign frame
- 3 Aluminum side panels welded to frame
- 4 8" x 8" x 3/4" thick below grade mounting plate
- 5 Reinforced concrete footer, to be engineered by fabricator
- 6 Precast concrete with 1" rod weldment
- 7 6" x 3" x 1/2" thick weld plate attaches to frame and base

Note:
Fabricator must isolate dissimilar materials.
All associated hardware must be stainless steel.
Install mow strip around sign bases with
river rock & metal edging around sign at lawn areas.

THIS DRAWING REPRESENTS DESIGN INTENT ONLY.
FABRICATOR WILL BE RESPONSIBLE TO VERIFY ALL
CONDITIONS IN FIELD PRIOR TO SHOP DRAWINGS.
REFER TO SIGN LOCATION PLAN AND MESSAGE
SCHEDULE FOR SIGN TYPES AND LOCATIONS.

Client/Project Western Michigan University Signage Bid Document		Project No. 14WMU249001
Date 12.12.16	Revisions	Scale As noted

ST 35 Small Building ID and St 36 X-small Building ID

DRAWINGS

3.38

Note: Install mow strip around sign bases with river rock & metal edging around sign at lawn areas.



2 Plan view ST 35
scale: 1"= 1'-0"



5 Plan view ST 36
scale: 1"= 1'-0"

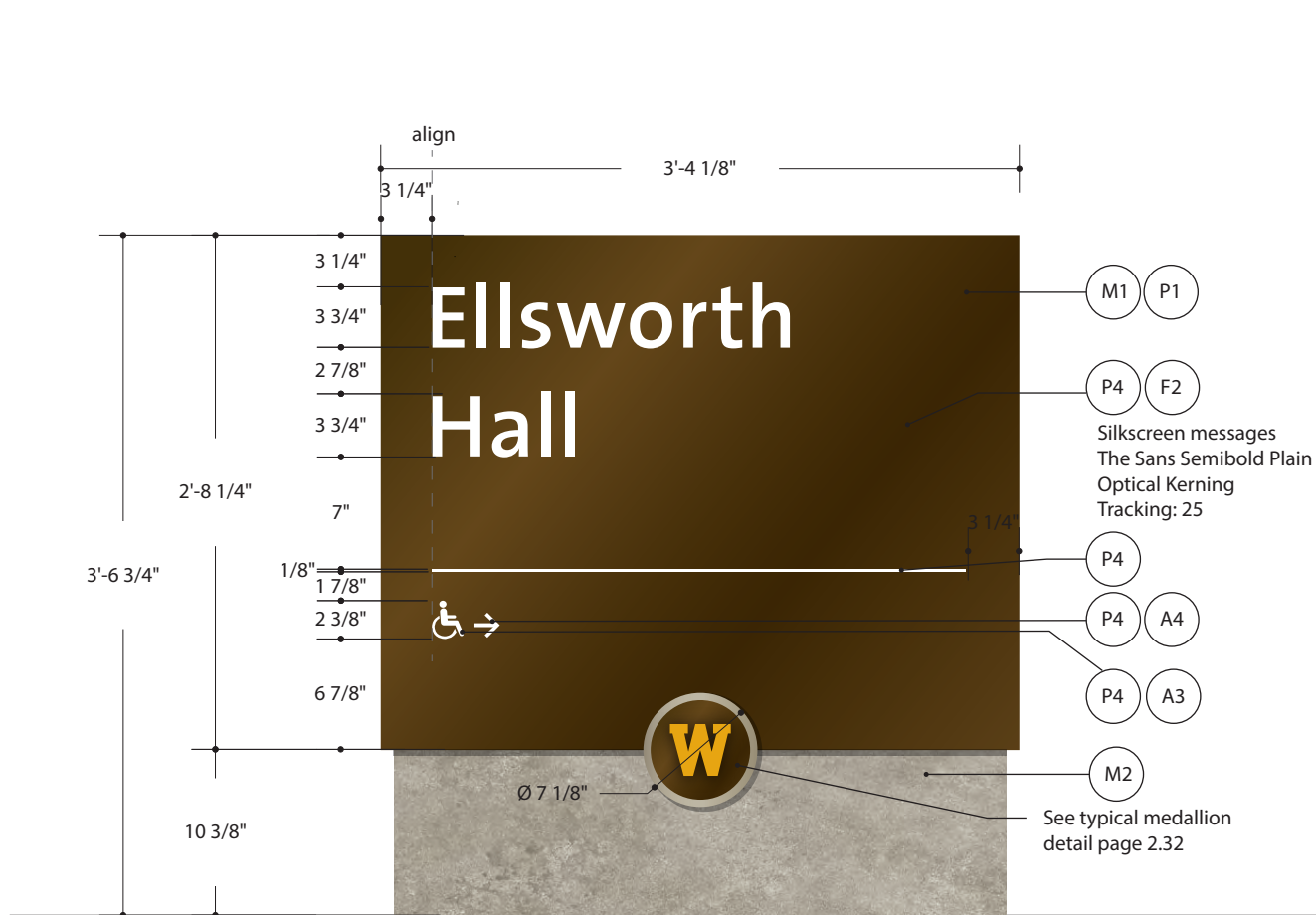

1 Elevation – Front and Back view – ST 35 Building ID - Small
scale: 1"= 1'-0"

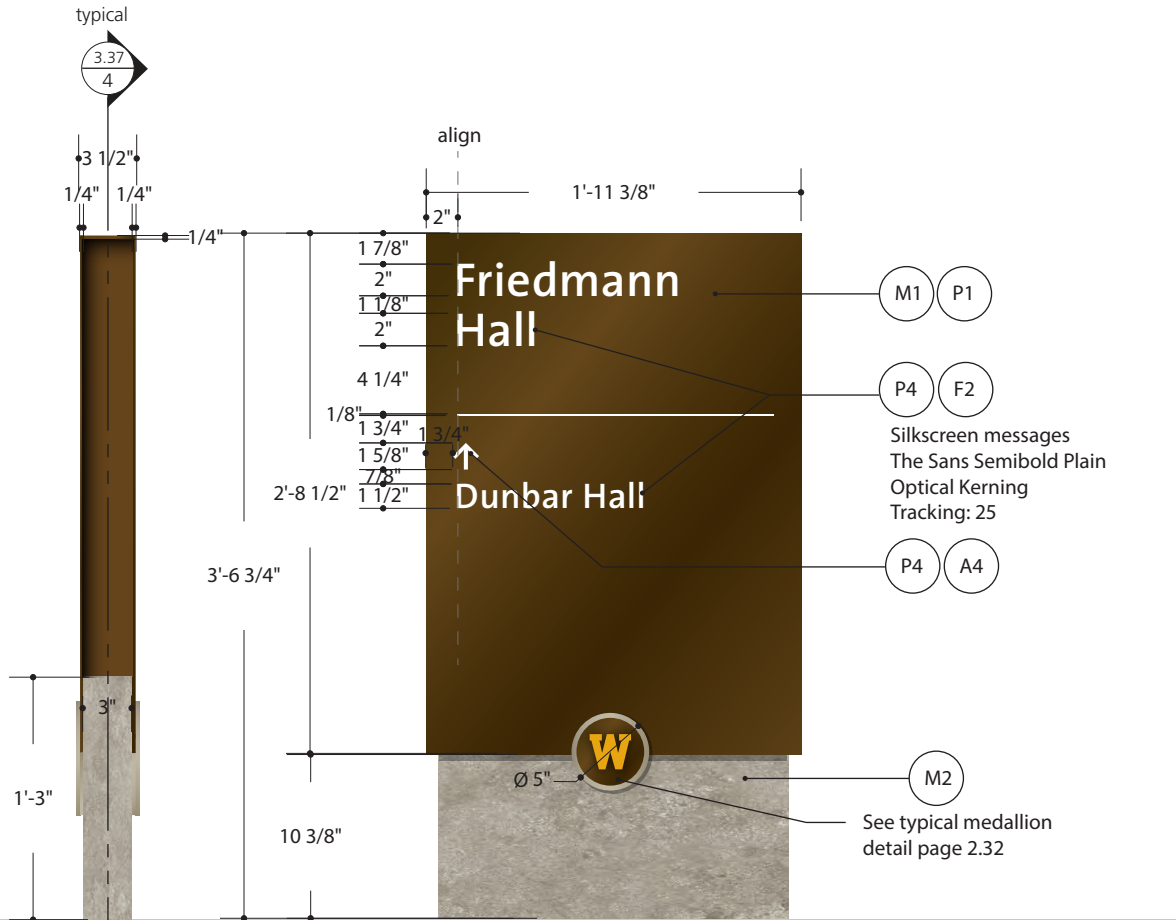

3 Side view ST 35 & ST 36
scale: 1"= 1'-0"

4 Elevation – Front and Back view – ST 36 Building ID - X-Small
scale: 1"= 1'-0"

THIS DRAWING REPRESENTS DESIGN INTENT ONLY.
FABRICATOR WILL BE RESPONSIBLE TO VERIFY ALL
CONDITIONS IN FIELD PRIOR TO SHOP DRAWINGS.
REFER TO SIGN LOCATION PLAN AND MESSAGE
SCHEDULE FOR SIGN TYPES AND LOCATIONS.

Client/Project Western Michigan University Signage Bid Document		Project No. 14WMU249001
Date 12.12.16	Revisions	Scale As noted

ST 40 Vinyl Building ID and ST 41 Building-mounted ID

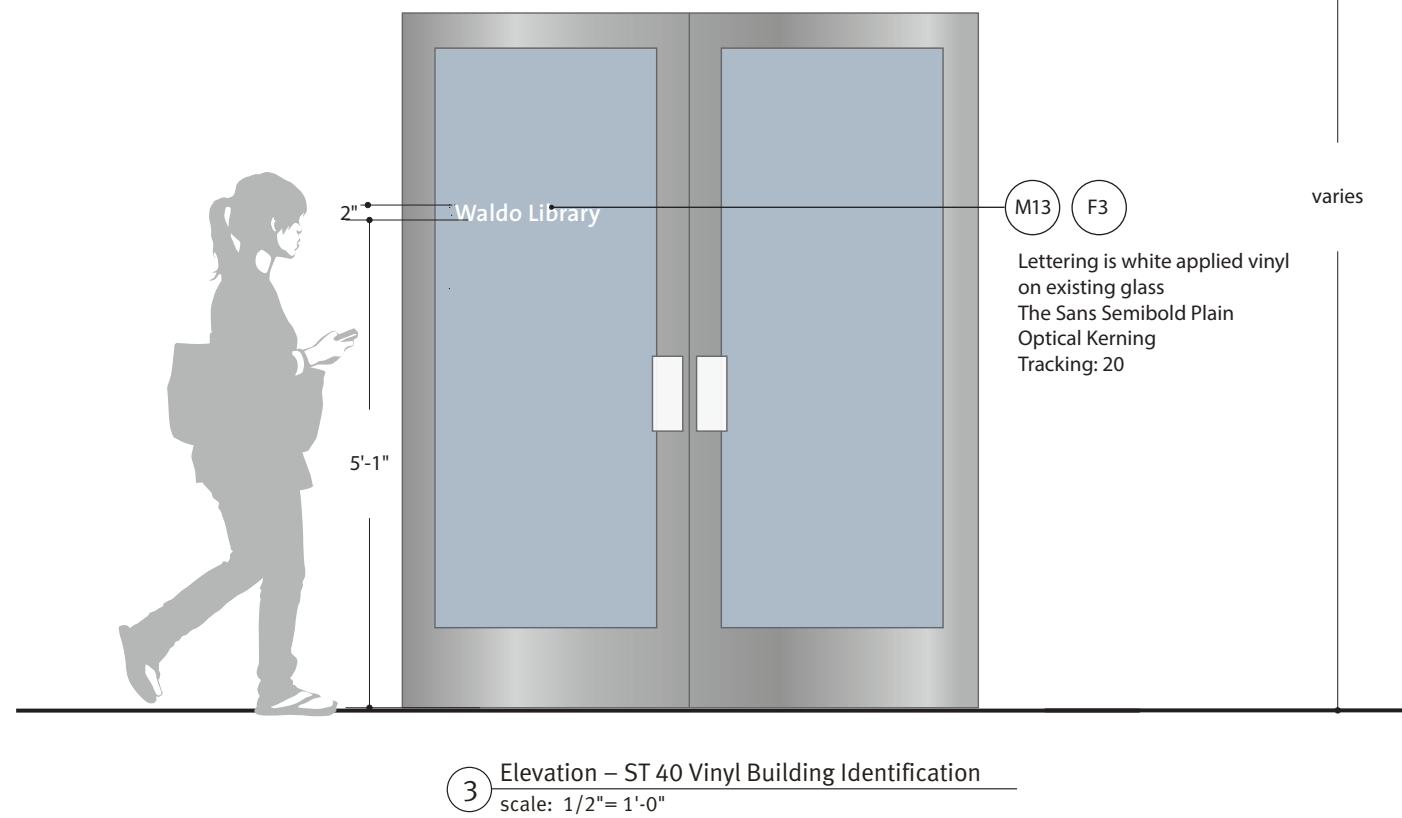
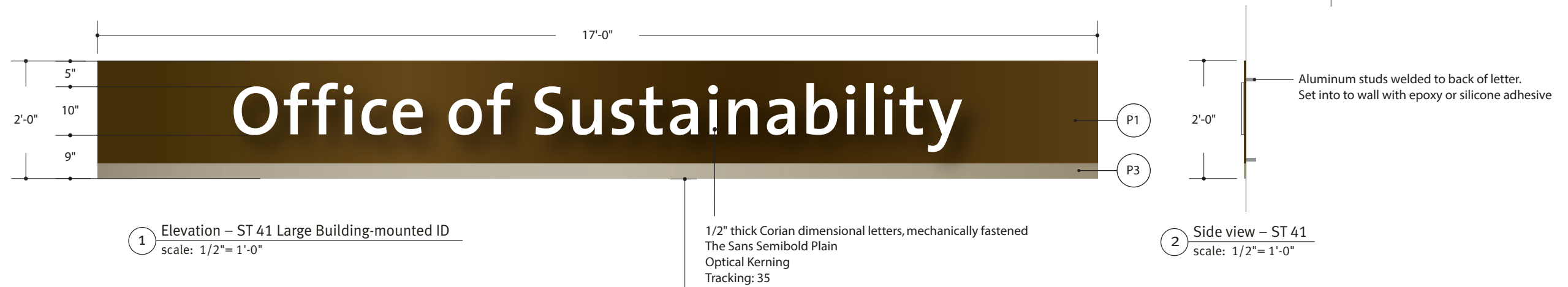

THIS DRAWING REPRESENTS DESIGN INTENT ONLY. FABRICATOR WILL BE RESPONSIBLE TO VERIFY ALL CONDITIONS IN FIELD PRIOR TO SHOP DRAWINGS. REFER TO SIGN LOCATION PLAN AND MESSAGE SCHEDULE FOR SIGN TYPES AND LOCATIONS.

Client/Project		Project No.
Western Michigan University Signage Bid Document		14WMU249001
Date	Revisions	Scale
12.12.16		As noted

ST 42 Recognition sign

DRAWINGS

3.42

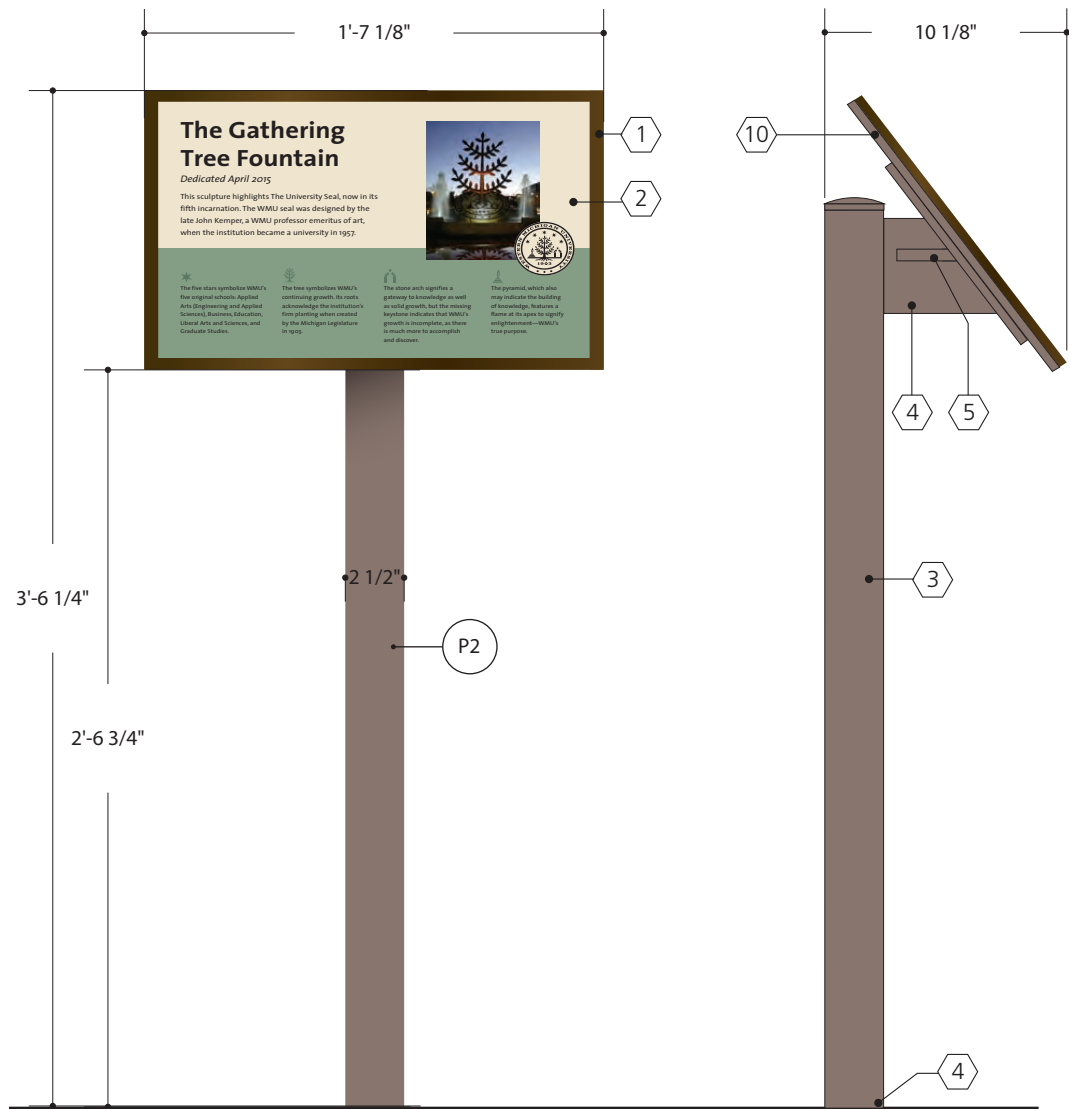

1 Elevation – ST 42 Recognition sign
scale: 1 1/2"= 1'-0"

2 Side view – ST 42 Recognition sign
scale: 1 1/2"= 1'-0"

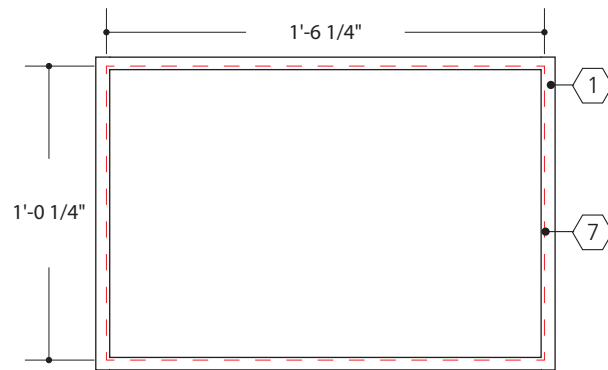

3 Elevation – Frame
scale: 1 1/2"= 1'-0"

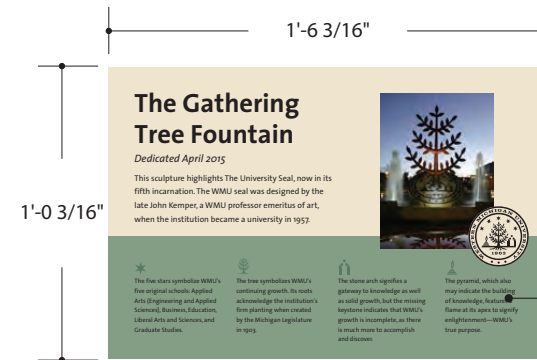

4 Elevation – Graphic insert panel
scale: 1 1/2"= 1'-0"

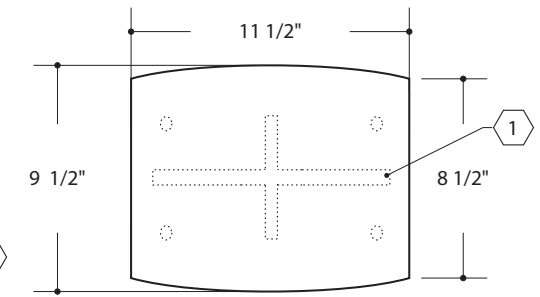

5 Elevation - Small backplate - ST 42
scale: 1 1/2"=1'-0"

Left Piece

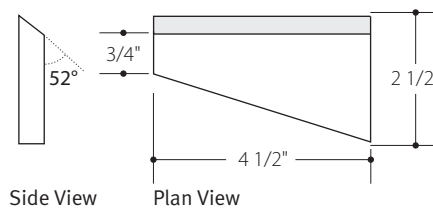

6 Attachment pieces
scale: 3"=1'-0"

Center Piece

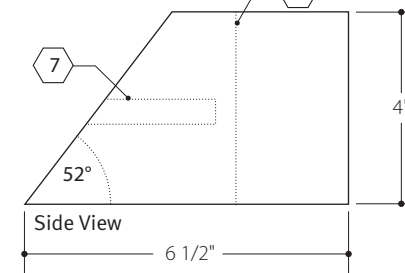

Right Piece

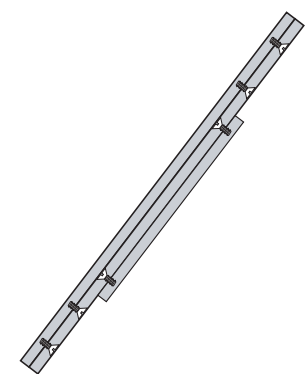
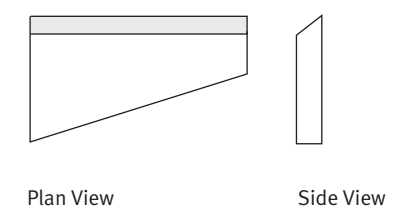

7 Screw placement detail
scale: 1 1/2"=1'-0"

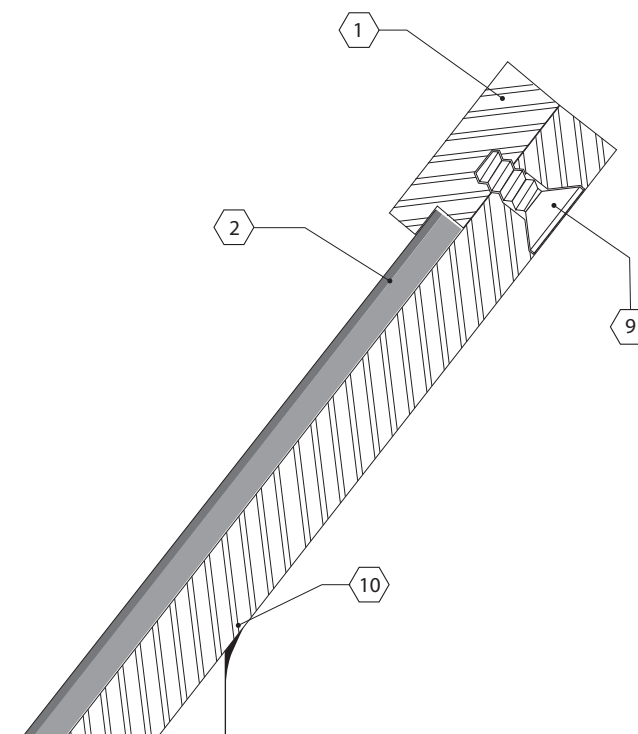

8 Detail - typical tableau frame construction
scale: full size

- 1 3/8" thick Aluminum frame, routed to accept interpretive panel
- 2 3/16" thick HPL insert panel
- 3 Ø 2 1/2" aluminum extruded upright tube
- 4 Direct burial. See details page 3.43
- 5 Dotted red line represents routed area. (Minimum 1/8" lip on all sides)
- 6 Plug-weld of supports
- 7 Location of left piece weld
- 8 Edge of sign post
- 9 Stainless steel machine screws countersunk with tamper resistant heads
- 10 3/8" thick aluminum plate welded to display post

Client/Project Western Michigan University Signage Bid Document		Project No. 14WMU249001
Date 12.12.16	Revisions	Scale As noted

THIS DRAWING REPRESENTS DESIGN INTENT ONLY. FABRICATOR WILL BE RESPONSIBLE TO VERIFY ALL CONDITIONS IN FIELD PRIOR TO SHOP DRAWINGS. REFER TO SIGN LOCATION PLAN AND MESSAGE SCHEDULE FOR SIGN TYPES AND LOCATIONS.

ST 43 Recognition sign - wall-mounted

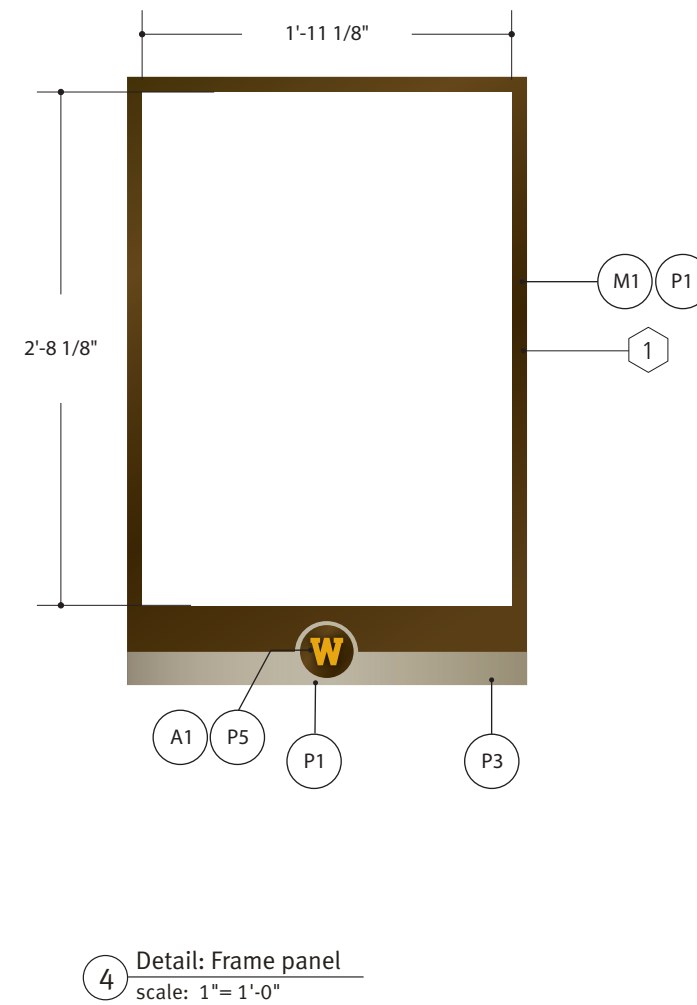
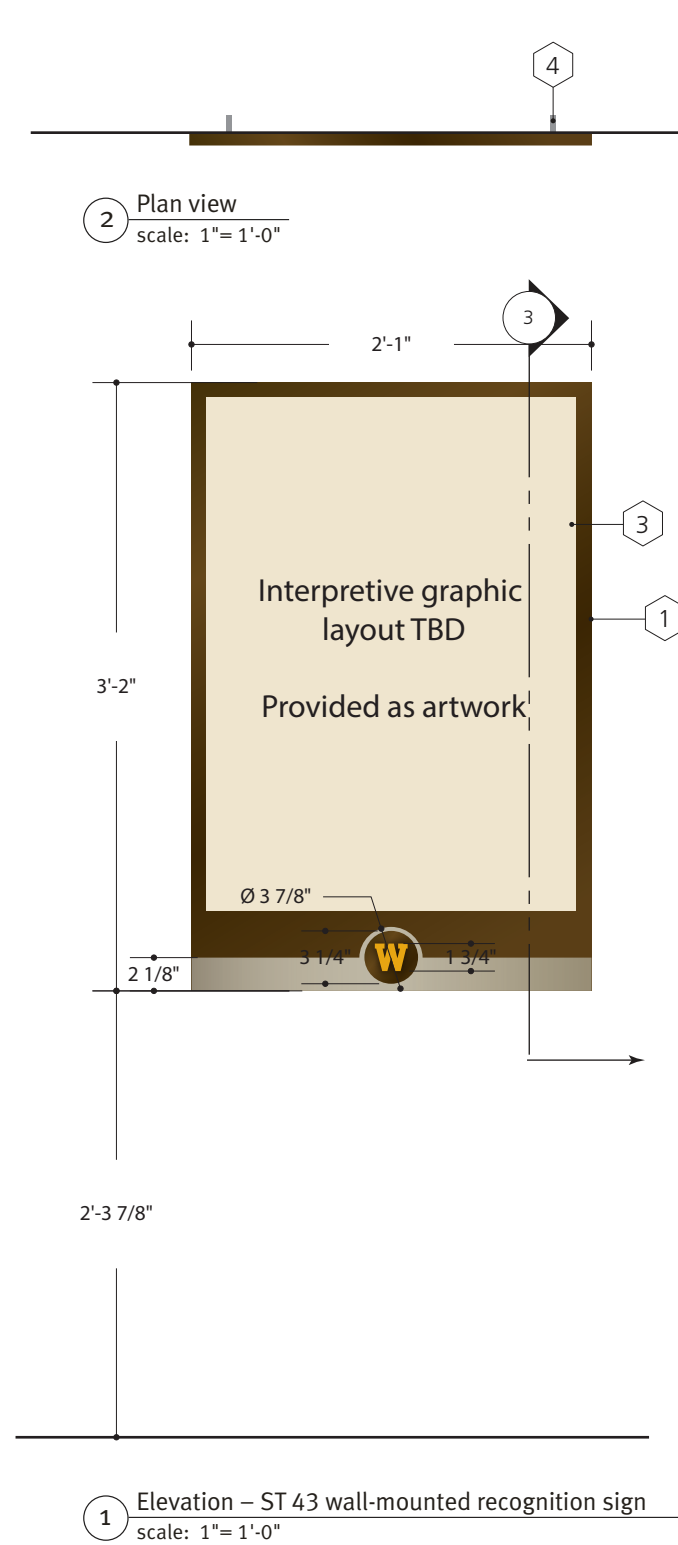

- 1 3/8" thick aluminum frame, routed out to accept graphic panel
- 2 1/4" thick aluminum back panel with z-clips anchored to face
- 3 3/16" thick HPL insert panel
- 4 Aluminum studs welded to back sign panel.
Set into to wall with epoxy or silicone adhesive.

THIS DRAWING REPRESENTS DESIGN INTENT ONLY.
FABRICATOR WILL BE RESPONSIBLE TO VERIFY ALL
CONDITIONS IN FIELD PRIOR TO SHOP DRAWINGS.
REFER TO SIGN LOCATION PLAN AND MESSAGE
SCHEDULE FOR SIGN TYPES AND LOCATIONS.

Client/Project Western Michigan University Signage Bid Document		Project No. 14WMU249001
Date 12.12.16	Revisions	Scale As noted

ST 45 & ST 46 Plaza signs

DRAWINGS

3.44

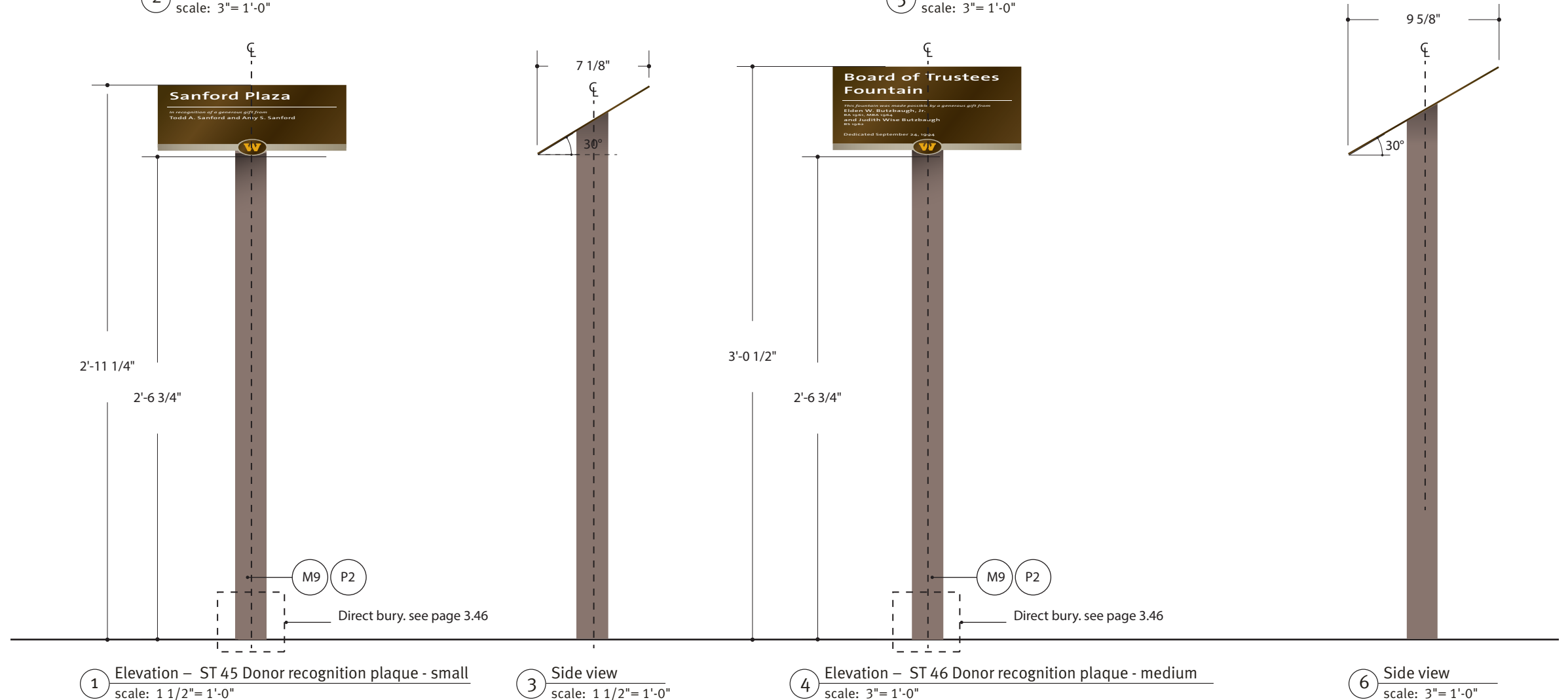
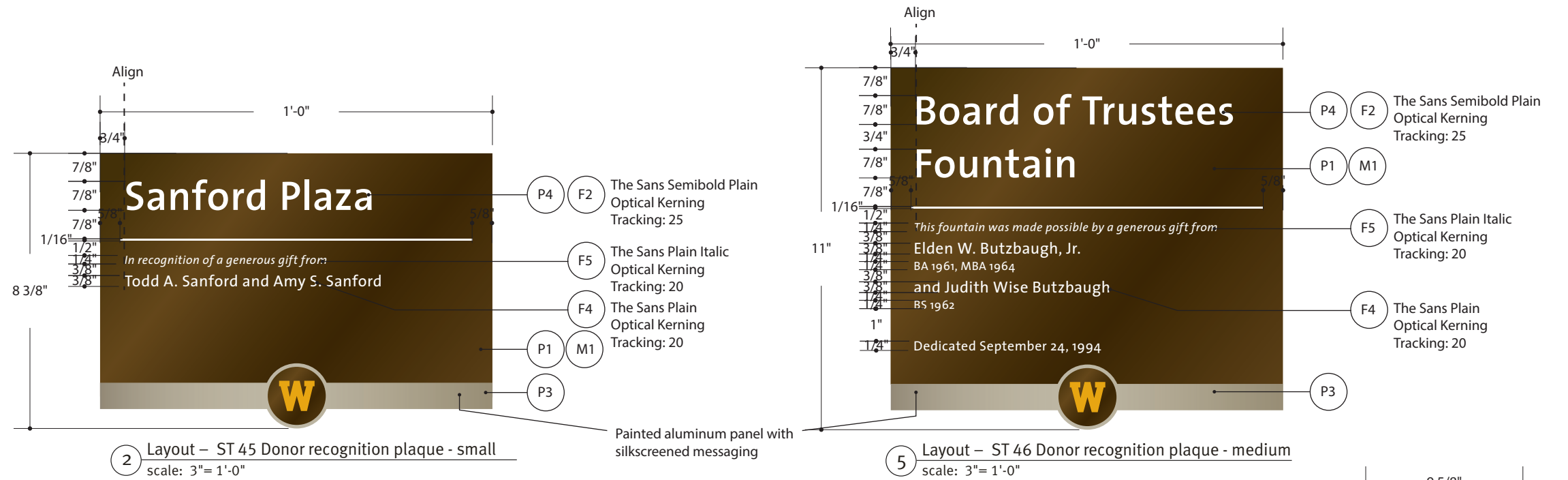

THIS DRAWING REPRESENTS DESIGN INTENT ONLY.
FABRICATOR WILL BE RESPONSIBLE TO VERIFY ALL
CONDITIONS IN FIELD PRIOR TO SHOP DRAWINGS.
REFER TO SIGN LOCATION PLAN AND MESSAGE
SCHEDULE FOR SIGN TYPES AND LOCATIONS.

Client/Project		Project No.
Western Michigan University Signage Bid Document		14WMU249001
Date	Revisions	Scale
12.12.16		As noted

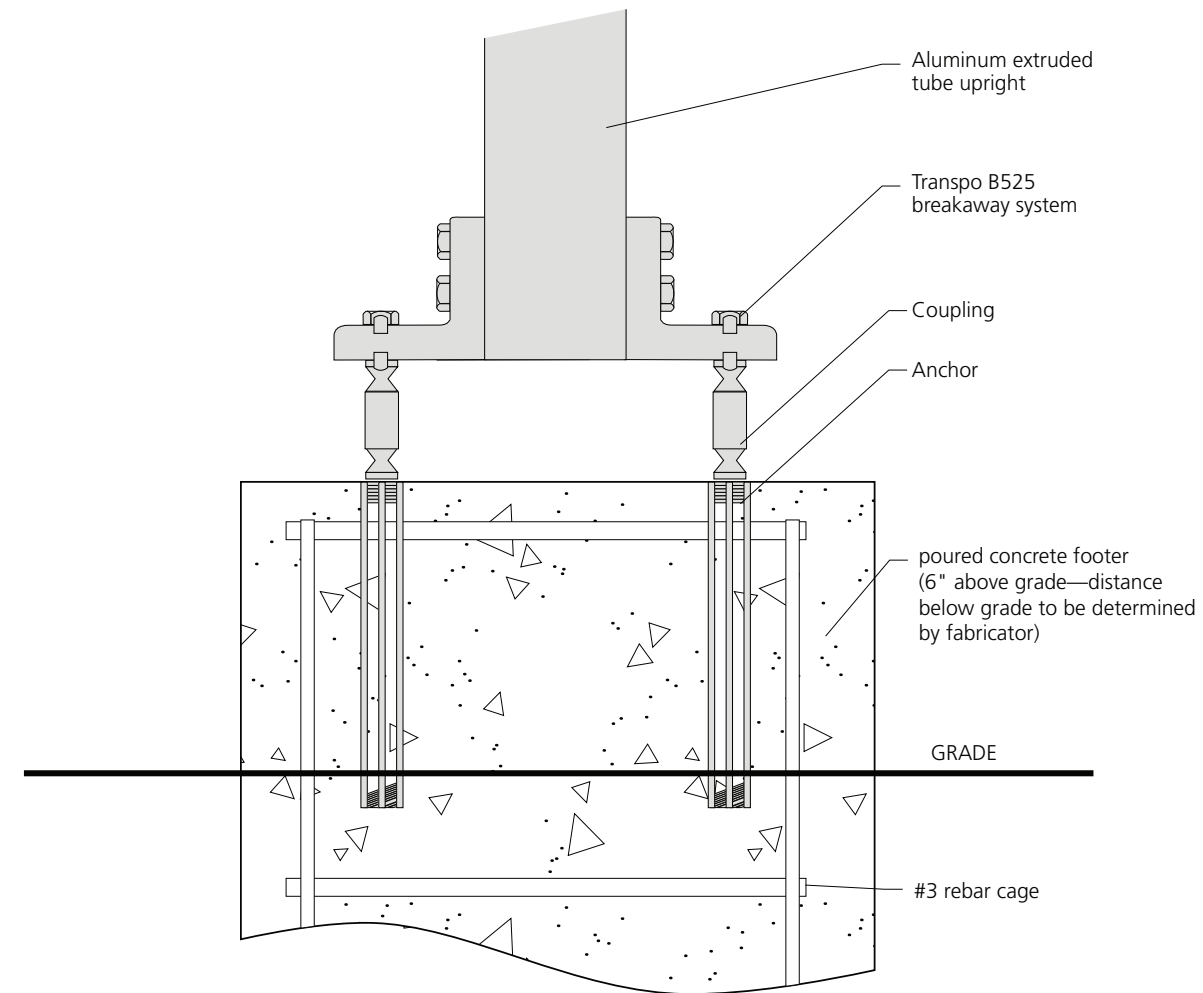

C Typical Section Detail - Concrete Footer
scale: nts

THIS DRAWING REPRESENTS DESIGN INTENT ONLY. FABRICATOR WILL BE RESPONSIBLE TO VERIFY ALL CONDITIONS IN FIELD PRIOR TO SHOP DRAWINGS. REFER TO SIGN LOCATION PLAN AND MESSAGE SCHEDULE FOR SIGN TYPES AND LOCATIONS.

Client/Project		Project No.
Western Michigan University Signage Bid Document		14WMU249001
Date	Revisions	Scale
12.12.16		As noted

Direct bury detail

DRAWINGS

3.46

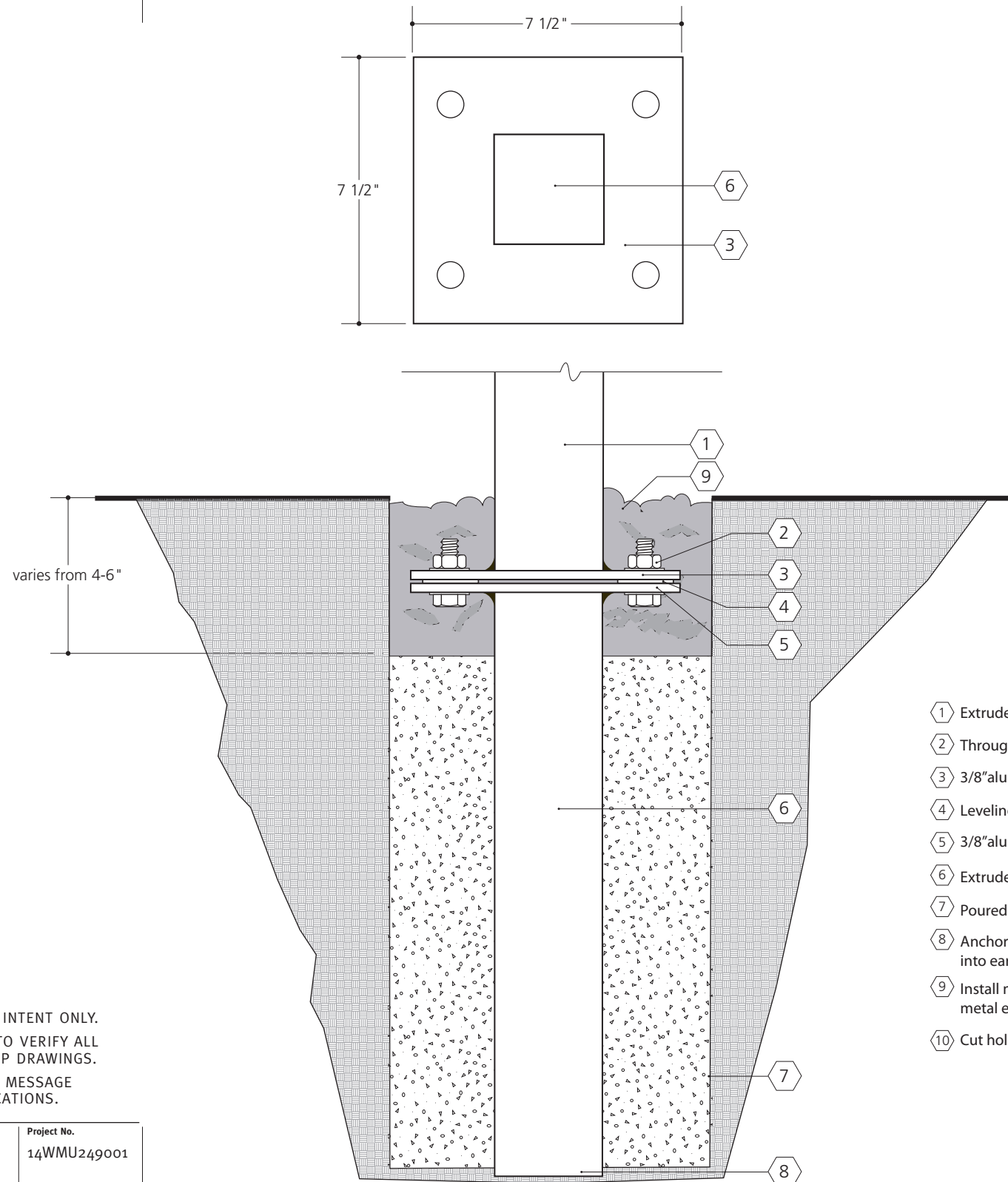

- ① Extruded alum tube upright (varies from Ø 2" to Ø 5")
- ② Through bolts
- ③ 3/8" alum baseplate welded to upright
- ④ Leveling washers
- ⑤ 3/8" alum matchplate welded to anchor tube
- ⑥ Extruded alum anchor tube
- ⑦ Poured concrete footer (fabricator to engineer footer size)
- ⑧ Anchor tube penetrates beneath footer into earth to allow drainage
- ⑨ Install mower strip around sign bases with river rock and metal edging around sign at lawn areas
- ⑩ Cut hole in base and match plates for water drainage

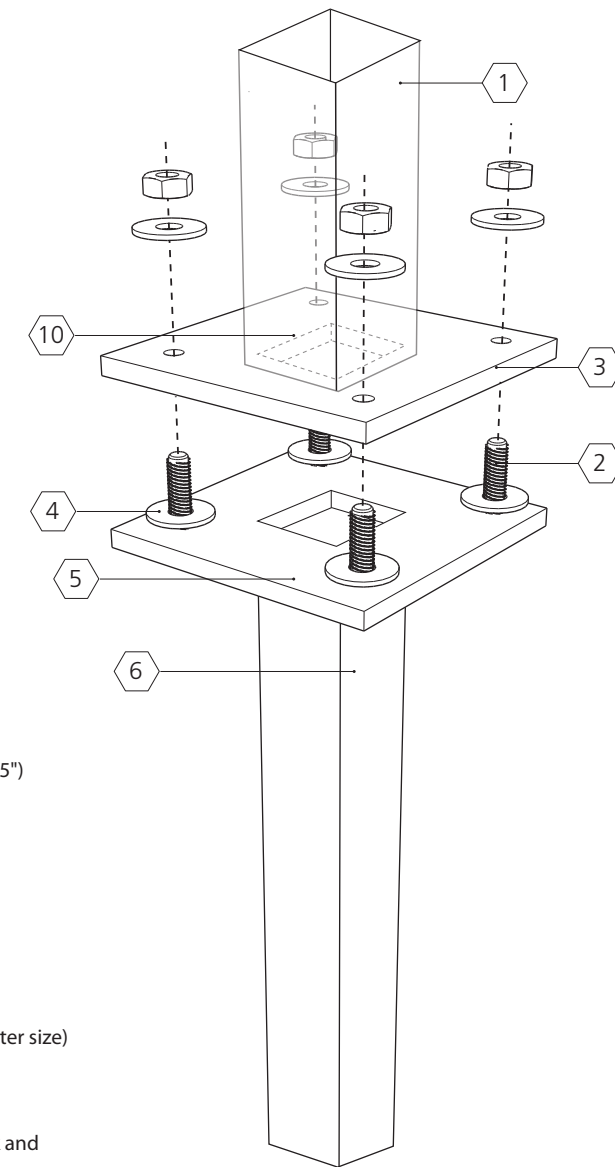

② Axo exploded view
n t s

① Typical match plate installation detail
scale: 3" = 1'-0"

THIS DRAWING REPRESENTS DESIGN INTENT ONLY. FABRICATOR WILL BE RESPONSIBLE TO VERIFY ALL CONDITIONS IN FIELD PRIOR TO SHOP DRAWINGS. REFER TO SIGN LOCATION PLAN AND MESSAGE SCHEDULE FOR SIGN TYPES AND LOCATIONS.

Client/Project Western Michigan University Signage Bid Document	Project No. 14WMU249001
Date 12.12.16	Revisions
Scale As noted	

Section 4 **Performance Specifications**

1.01 Work Included

- A** Labor, materials, equipment and services necessary for the fabrication, delivery and installation of signage as described in the detail drawings.
- B** Refer to the message schedule for a complete list of sign types and quantities.
Signs listed on message schedule should match those indicated on sign location plans. Contractor to notify owner of any discrepancies in sign quantities by doing take-offs before manufacturing signs.
- C** Signage is located at Western Michigan University in Kalamazoo, Michigan.
- D** For all signs, all fasteners, support structures required for installation.

1.02 Related Work

- A** General requirements: all work to be done in a professional manner and to the highest trade standards.
- B** Use OSHA safety requirements if necessary for pedestrian or vehicular safety.

1.03 Regulatory Requirements

- A** Observe applicable codes, sign ordinances and ADA guidelines for handicapped and fire/life safety signing.
- B For Electrical Work**
 - 1 National Electrical Code
 - 2 National Electrical Safety Code
 - 3 Life Safety Code - NFPA 101
 - 4 OSHA
 - 5 Applicable Federal, State and Local Codes
 - 6 Underwriters Laboratory Inc. (UL)

1.04 Reference Standards
Refer to current editions of the following:

- A** ASTM B221—Aluminum-alloy extruded bars, rods, wire, shapes and tubes.
- B** ASTM D822—Light and water exposure apparatus (carbon-arc type) for testing paint, varnish, lacquer and related products.
- C** ASTM A276—Stainless Steel -alloy extruded bars, rods, wire, shapes and tubes.
- D** ASTM E84—Surface burning characteristics of building materials.
- E** FS L-P-391—Plastic sheet, rods and tubing, rigid, cast, materials.
- F** FS L-P-387—Plastic sheet, laminated, thermosetting.

- G** ASTM C 880—Stone, granite flexural strength testing
- H** ASTM C 1354—Stone, granite anchorage testing
- I** PEI—Porcelain Enamel Institute.
- J** UL 943—Fluorescent lamp ballasts.
- K** ASTM A36—Structural Steel
- L** ASTM A123—Zinc (Hot Galvanized) coatings on products fabricated from rod, pressed and forged steel shapes, plates and bars.
- M** TM B135 QQ-B-613 (Fed Spec)—Brass, Muntz 280
- N** PS-1—Construction and industrial plywood.
- O** CDA—Copper Development Association, Inc.
- P** AWI—Comply with applicable requirements of “Architectural Woodwork Quality Standards” published by the Architectural Woodwork Institute.
- Q** ASTM- WK10687 New Standard Practice for the Determination of Luminance under Monochromatic LED Illumination
- R** ASTM C 143-74—Concrete slump test.
- S** ASTM D3933-98 - Standard Guide for Preparation of Aluminum Surfaces for Structural Adhesives Bonding (Phosphoric Acid Anodizing)

1.05 Submittals
A Bid submittal requirements

- 1 All of the following bid submittals must be provided to be considered a qualified bid.
- 2 All proprietary contractual paperwork provided by the client filled out accurately, including all requested bonding and insurance information.
- 3 Submit completed spreadsheet (file provided) with all requested line item prices. Ensure that all row and column totals add up properly. Use the provided format, do not use a different spreadsheet format.
- 4 Submit a projected project schedule. Schedule will show major milestones such as sample submittals, fabrication, and installation. The payment schedule will be tied to reaching these milestones. Schedule will be updated regularly throughout the project.

B Requirements

- 1 Schedule shop drawings, product data and sample submittals for delivery at the same time.
- 2 The owner may hold shop drawings, product data and samples in cases where a partial submittal cannot be reviewed until associated items have been received.
- 3 Allocate not less than two weeks, plus mailing time, for processing by the owner.

C Schedule

- 1 Submit Gantt style schedule with all pertinent dates and milestones for the project.
- 2 Include submittal delivery dates, fabrication and installation dates
- 3 Allow several weeks in schedule for review and revision time for all submittals.
- 4 Revise schedule regularly as project details dictate.

D Shop Drawings

NOTE: All final shop drawings must have an engineering stamp from a state licensed engineer before being approved for fabrication.

- 1 Submit three (3) sets of shop drawings as outlined below.
- 2 Include plans, elevations, sections and large scale details of sign wording and lettering layout for each sign in the message schedule. Show anchorages and accessory items. Provide mounting templates.
- 3 Show fabrication and installation details, including all sign components such as extrusions, brackets, bracing, hardware, internal framing, foundations, etc.
- 4 Provide engineering data to confirm viability of signs and supports, including structural stability of all signs, fasteners and foundation design.
- 5 Structural details must be reviewed and stamped by a state certified structural engineer, ensuring structural integrity and safety.
- 6 For illuminated sign units: shop drawings shall also include the following:
 - a Fixture type.
 - b Fixture and lamp/ballast voltage.
 - c Fixture and lamp wattage.
 - d Complete photometric data.
 - e Wiring diagrams, including connection to building power supply.
 - f UL registration number (fabricator MUST be UL approved).

E Subcontractor qualifications information

- 1 The total percentage of subcontracted work on this project is not to exceed 25% including installation.
- 2 **Fabricator must submit credentials for any subcontractor selected to execute any portion of this contract. This must be submitted with proposal or bid. Demonstrate subcontractors qualifications for doing specified work.**

THIS DRAWING REPRESENTS DESIGN INTENT ONLY. FABRICATOR WILL BE RESPONSIBLE TO VERIFY ALL CONDITIONS IN FIELD PRIOR TO SHOP DRAWINGS. REFER TO SIGN LOCATION PLAN AND MESSAGE SCHEDULE FOR SIGN TYPES AND LOCATIONS.

Client/Project		Project No.
Western Michigan University Signage Bid Document		14WMU249001
Date	Revisions	Scale
12.12.16		As noted

F Samples

- 1 Submit three sets of each sample as required.
- 2 Owner reserves the right to reject any samples that do not satisfy the construction, finish or color requirements. Submit additional samples as required to obtain final approval.
- 3 Samples shall be labeled on the back, designating item number, name of manufacturer, sign type and location.
- 4 Samples should represent extreme variations in color and texture that might occur during fabrication.
- 5 Samples are required for the following products:
 Paints
 M4 - Direct print to retro-reflective vinyl
 M5 - Precast concrete
 M6 - Full size print of vinyl map graphic
 M7 - Acrylic letter with M13 applied to back
 M11 - Glass
 M12 - 3M Translucent Graphic film
- 6 An installable prototype is recommended for the following sign types:
 Sign Type 10 Vehicular Directional - Small
 Sign Type 15 Parking Regulatory
 Sign Type 27 Pedestrian Directional w/ map
 Sign Type 32 Building ID - Large
 Sign Type 34 Building ID - Medium
- 7 Prior to final shop drawing submission, fabricator to create a scaled partial mock-up to test the glass tower element for the tall center component of the gateways (GW3-003). Mock-up to detail the glass laminates opacity and recommended light fixture illumination and wash of the glass. Mock-up to include two (2) glass opacity options for review. Client and design team will provide final approval on materials based on mock-up review.

G Maintenance Data

- 1 Submit two (2) copies of each manufacturer's recommendations for maintenance of all items.
- 2 The instructions shall cover cleaning, repair, repainting and maintenance of signs, including data on cleaning solutions or methods of application which should be avoided.

1.06 Delivery OF ATTIC STOCK (if any)

- A** For any attic stock ordered, package separately or in like groups labeled as to contents. Include installation hardware, adhesives and installation instructions; include a reasonable array of alternate adhesives, fasteners or materials to be able to respond effectively to varying field conditions.

1.07 Protection

- A** Store and protect assemblies from injury at the shop, in transit to the job and until erected in place, completed, inspected and accepted.
- B** Packaging should not be taped to sign surface. Bubble wrap should be removed upon delivery to prevent damage to sign surfaces.
- C** Take special precautions to prevent pilferage both prior to and after installation. Be prepared to provide replacements for any material so removed from the site.

1.08 Inspection

- A** Materials, colors and fabricated or partially fabricated items shall be available for inspection at the factory or elsewhere, by the owner or designer during the process of manufacture and until final delivery, installation and acceptance, to determine whether or not there is compliance with the requirements of these specifications.
- B** Approval prior to the time of final acceptance shall not preclude rejection of delivered items which do not satisfy these specifications.

1.09 Reordering

- A** All items specified herein shall be available to the owner in additional quantities for a period of 10 years after completion of all work called for in this specification.

1.10 WARRANTY

All warranties on fabricator's standard contract forms must be modified to match warranty criteria mentioned herewith. Any changes in warranty length or criteria must be negotiated prior to contract signing. Any discrepancies from fabricator's contract are superseded by this performance specification.

ALL PAINT FINISH WARRANTIES MUST BE ACCOMPANIED BY SIGNED WARRANTY AGREEMENTS WITH THE PAINT MANUFACTURER AND FINISHER.

- A** Warrant all products (including, but not limited to, materials, hardware and finishes) against any and all defects due to workmanship for a minimum period of 2 years from date of installation.
- B** Correct any and all defects in material and/or workmanship which may appear during the warranty period by restoring defective work to the standard of the contract documents at no cost to the owner and to the owner's satisfaction.
- C** Vinyl die-cut letters shall be warranted for five years against delamination from substrate.

- D** Correct any and all paint finish defects which may appear during the warranty period by restoring defective work to the standard of the contract documents at no cost to the owner and to the owner's satisfaction.

PAINT FINISHES SHALL BE WARRANTED AS FOLLOWING:

- 1 All Matthews paint products must be clear coated with MPC super Satin Clear Kit, a two-component 1.24 ready to spray VOC compliant, acrylic polyurethane clear, which was developed to provide extended performance under the toughest conditions. See the MPC194 specifications on page 5.2. Fabricator to provide extended warranty from Matthews to client on completion of project.
- 2 PPG Corafon fluoropolymer solvent-based paint - 10 years for gloss retention as measured in accordance with ASTM D523 using 60 degree readings. 10 years for color retention as measured by ASTM D2244 Section 6.3 using Hunter LAB Color difference.

- E** Additional corrections shall include, but not be limited to, the following:

- 1 Bubbling, crazing, chalking, rusting or other disintegration of the sign face or of the messages or of the edge finish of the sign inserts or panel.
- 2 Corrosion developing beneath paint surfaces of the support systems (except when it is the result of obvious vandalism or other external damage to the paint surfaces).
- 3 Corrosion of the fastenings.
- 4 The signs not remaining true and plumb on their supports or walls.
- 5 Fading of the colors when matched against a sample of the original color and material.
- 6 Discoloration of metal finishes.
- 7 Uneven illumination; dark or hot spots.

1.11 ALTERNATE FABRICATION

- A** The drawings show design intent only. The fabricator is responsible for fabrication and overall level of quality. Any changes in design, materials, fabrication techniques or details necessary to the successful completion of this project should be communicated to owner in a timely fashion.

Further development and engineering of designer's details (for fabrication and installation) is expected and should be shown in the shop drawings.

THIS DRAWING REPRESENTS DESIGN INTENT ONLY. FABRICATOR WILL BE RESPONSIBLE TO VERIFY ALL CONDITIONS IN FIELD PRIOR TO SHOP DRAWINGS. REFER TO SIGN LOCATION PLAN AND MESSAGE SCHEDULE FOR SIGN TYPES AND LOCATIONS.

Client/Project Western Michigan University Signage Bid Document		Project No. 14WMU249001
Date 12.12.16	Revisions	Scale As noted

PERFORMANCE SPECIFICATIONS

4.4

- B** The designer recognizes that manufacturers may have shop fabrication techniques that differ from details shown. Suggested changes in fabrication that do not alter the design intent nor reduce the quality will be considered by the designer provided they are submitted in sketch form as soon as possible prior to shop drawing preparation.
- C** Any value engineering changes during fabrication shall be credited to the owner.

2.01 Quality Assurance

- A** Materials used for this project shall be new and not reconditioned or re-purposed.
- B** Use only personnel thoroughly skilled and experienced with the products and method for fabrication and installation of signage specified.
- C** The owner shall reserve the right to reject any shop drawings, samples or other submittals, as well as any finished product or installation, that cannot meet the standard of quality established. Any such decision will be considered final and not subject to recourse.
- D** The intent of the contract documents is to provide everything necessary for a complete contract. In the event of conflict or omission, the fabricator shall consult the owner for resolution.
- E** Materials and hardware not specified, but necessary to the complete functioning of the sign, shall conform to the quality level established.

2.02 Preferred material suppliers

- A** Products listed below are specified for this project. These products have either been tested on prior projects and have delivered proven results, or have properties unique to this project. Any suggested substitutions must have documentation demonstrating the same level of quality and warranty **prior** to bidding. Bids are subject to disqualification if unauthorized substitutions are used.
- B As listed under specific headings.**
See drawings for manufacturers of specified materials.

2.03 Sign Types

- A Factory silkscreen or mask and spray:**
 - 1 On aluminum
- B Vinyl graphics (letters or other die-cut shapes):**
 - 1 On aluminum

C Aluminum structures:

- 1 Extrusions, as noted.
- 2 Aluminum sheet or plate, rolled as necessary.
- 3 Aluminum hardware.

2.04 Design Requirements

The contractor shall be responsible for the message layout of all directional message panels. Fabricator must produce scale drawings of message layouts for review prior to fabrication. Layout spacing and letterheights to be based on typical layout guideline drawing pages. Any discrepancies or unusual layout issues should be brought to the attention of the designer.

A Type specifications

- 1 Typeface: the following typefaces as manufactured by Adobe Systems are used (NO substitutions will be accepted):
 - F1) Clearview Hwy 3-W
 - F2) The Sans Semibold Plain
 - F3) The Sans Bold Plain
- 2 Size: all letter heights specified are based on the height of a capital letter.
- 3 Alignment: When setting type or installing cut letters, ensure that letters are perfectly straight and even, with no characters set crooked or "popping up."
- 4 Spacing
 - a See drawings for samples of letterspacing programs. The proper letter and word spacing is of extreme importance to the desired look of the signs.
 - b Drawings were prepared in Adobe Illustrator CS6, Version 16.0.0, with a specified kerning/letterspacing/tracking option for all upper/lower case/capital letters. The general kerning should be set at optical.
 - c Contractor is responsible for visual corrections to the typesetting that might be necessary. Any problems in spacing or copy fitting should be brought to the attention of the designer for solution.

B Visual justification

- 1 Display type may align mechanically but not optically. When flushing copy message left, a visual adjustment shall be made compensating for those letter forms that must be extended into the left hand margin to appear flush. For example, S and O must extend beyond the left margin slightly.

C Arrow and symbol specifications

- 1 Symbols: symbols and pictographs shall conform to the symbol signs issued by the Department of Transportation and the American Institute of Graphic Arts. To obtain more information and reproduction art-

work or digitized Macintosh compatible AI GA symbols, contact:

Society for Environmental Graphic Design
1000 Vermont Avenue
Suite 400
Washington, DC 20005
202.638.5555

- 2 Arrows on all signs shall use the arrow files which will be provided by the owner to the successful bidder. Arrow size will be dimensioned by height as shown in the drawings.

D Artwork

- 1 The contractor shall be provided electronic AI CS6 files with project artwork and templates. The final output quality of artwork for finished signage shall be the responsibility of the contractor. The owner's representative reserves the right to reject artwork if it fails to meet the standard of quality established.

2.05 Materials

A Aluminum extrusions: for mounting plates and structural frames shall conform to ASTM B- 221, Alloy 6063-T6. Shapes, sizes and weights of members shall be as required for structural stability. All connections of aluminum members shall be heli-arc welded, continuous fillets, ground smooth on all exposed faces, unless specifically detailed otherwise. Aluminum finishes shall be hereinafter specified.

B Aluminum sheet and plate: Type 5052-H-32 alloy aluminum, thickness as indicated. For painted finish, faces shall be etched to give an even satin finish and remove oxidation, then conversion coated to improve paint adhesion and inhibit corrosion. Surface shall be belt-sanded for a smooth finish, edges filed and ground then immersed in hot alkaline cleaner to remove contamination. For anodized finish, prepare for finish AA-M31-C21-A31.

Coating to protect aluminum by uniformly penetrating, filling and sealing surface pores. Coating should provide an invisible barrier to weathering, airborne contaminants, graffiti, industrial air pollution, mildew and salt air. Coating should not yellow, peel or flake. Coating should be guaranteed a minimum of seven years. Sign panels shall be pre-drilled in proper locations before any priming, painting or coating processes.

Aluminum should have consistency of color and finish throughout the project.

C Hangers, brackets and accessories: shall be of the type and size indicated. Where such items are not specifically called for, provide hangers, brackets and accessories as required for the proper execution of the work, as approved by the owner.

THIS DRAWING REPRESENTS DESIGN INTENT ONLY. FABRICATOR WILL BE RESPONSIBLE TO VERIFY ALL CONDITIONS IN FIELD PRIOR TO SHOP DRAWINGS. REFER TO SIGN LOCATION PLAN AND MESSAGE SCHEDULE FOR SIGN TYPES AND LOCATIONS.

Client/Project		Project No.
Western Michigan University Signage Bid Document		14WMU249001
Date	Revisions	Scale
12.12.16		As noted

D Finishes for aluminum

All finishes to protect aluminum by uniformly penetrating, filling, and sealing surface pores. Coating should provide an invisible barrier to weathering, airborne contaminants, graffiti, industrial air pollution, mildew, and salt air. Coating should not yellow, peel or flake. Coating should be guaranteed a minimum of seven years. Sign panels shall be pre-drilled in proper locations before any priming, painting or coating processes.

Aluminum should have consistency of color and finish throughout the project.

Aluminum components must be finished in one of the following paint types:

1 Acrylic Polyurethane - Matthews Paint

Ultraviolet inhibited aliphatic isocyanate acrylic system engineered for extreme color and gloss retention. Degree of gloss is specified in design drawings. One coat 74- 734 and 74-735 metal pre-treat at .25 mils DFT or one coat 74-793 spray bond at .15 to .25 mils DFT and one coat Matthews Acrylic Polyurethane 2 mils DFT. As a final step, spray one coat of satin clear Matthews Acrylic Polyurethane 2 mils DFT for a protective top coat

2 Fluoropolymer -Solvent based -Corafalon ADS - PPG

Two component fluoropolymer finish with 100% FEVE (fluoropolymer) resin and an aliphatic isocyanate curing agent. Degree of gloss is specified in design drawings. Solvent clean bare aluminum per SSPC SP-1. ADS wash primer ADS225/ADS226 @ .03-.05 Mils DFT.

For components with textured finishes:
Use single coat of Matthews Acrylic Polyurethane (black) with Matthews 287113SP suede additive for texture. Apply Corafalon topcoat in color specified.

Paint touch-up process - Corafalon

1 Do not touch up scratches using paintbrush.

2 Prep area by sanding with a very fine grit sand paper. Mix Corafalon products on site immediately before spraying. Spray all locations with scratches in one batch. Mix Component A - Corafalon ADS and Component B - Corafalon ADS1B (curing agent) Spray. Expected pot-life for this product is four

hours. Apply paint using a PREVAL Spray Gun - available at:
www.prevalspraygun.com

3 Spray in an even motion, feathering the edge of the spray perimeter

4 Protect message panels, adjacent areas and ground beneath signs from overspray.

3 Grip-gard® BC basecoat solid, metallic and pearl colors - Akzo Nobel

1 Grip-Gard BC Basecoat is designed specifically to meet the color, application and quality demands of the Sign and Exhibit Manufacturer. With extremely fast tape times and a tremendous range of solid, metallic and pearl colors, Grip-Gard BC Basecoat is ideal for fast production, particularly on multi-color signs. Grip-Gard BC Basecoat must be used in conjunction with Grip-Gard BC Clearcoat in order to provide protection from the environment.

All products that are to be sanded: you may have to initial sand, but final sanding with #P500 to #P600 grit paper dry or #P600 to #P800 grit wet is recommended.

Get-on-wet products: please follow recommendation for product in use by consulting the relevant Technical Data Sheet.

Please reference the grip-gard® bc basecoat solid, metallic and pearl colors technical data sheet top-coats.

4 Anodizing

Phosphoric acid anodizing is a chemical and electric treatment to aluminum to produce a hard, transparent surface that is integral with the base aluminum.

Aluminum shall be properly cleaned and pretreated prior to anodizing process.

E Pressure sensitive legends

1 Use "Scotchcal" brand film manufactured by 3M. Thickness: .003 inch minimum, .006 inch maximum. Material shall consist of a tough, flexible, pigmented, vinyl film and shall be processed with compatible screen printing inks and clear coatings as recommended by the film manufacturer. The film shall be

pre-coated with pressure-sensitive adhesive. The adhesive shall be protected by a treated paper liner which shall be easily removable without soaking in water or other solvents.

2 Use "Scotchlite" brand reflective sheeting manufactured by 3M. Thickness: .0065 inch minimum, .0075 inch maximum. Material shall consist of transparent plastic having a smooth, flat outer surface embedded with spherical lens elements. Material shall be capable to being processed with compatible screen printing inks and clear coatings as recommended by the sheeting manufacturer. The sheeting shall be pre-coated by a treated paper liner that shall be easily removable without soaking in water or other solvents.

3 Shall be guaranteed against delamination for a period of 5 years.

F Silkscreen ink

Formulate epoxy silkscreen inks specifically for surfaces on which they will be used. Add catalytic or bonding agents as necessary to maximize adherence and vandal resistance.

G Direct Substrate Printed Media

1 Process: "Direct Substrate Printers" shall provide high-quality, full color images directly onto a variety of flat substrates. Substrate examples include (but are not limited to) Acrylic, PVC, Polycarbonate, Aluminum, Stainless Steel, Wood, etc.

2 Printer Characteristics: printer to have C, M, Y, K, CL and W print heads (minimum) with UV curable inks and UV LED Lamp to cure ink while printing. Minimum reproduction print quality up to 1440 dpi. Flatbed printing size for substrates up to (and including) 48" x 96". Printer to accept substrates up to 2" thick.

3 Capabilities: Printer to have white ink capabilities to create under-coat/primer on dark substrates and opaque under-coat/primer on clear substrates. Clear ink to provide protective over-coating and variable sheen finishes including full-surface glossy printing. Printer to have mask pattern capability to effectively curb visible banding. Printer to have variable drop function to produce smooth and natural gradations.

THIS DRAWING REPRESENTS DESIGN INTENT ONLY. FABRICATOR WILL BE RESPONSIBLE TO VERIFY ALL CONDITIONS IN FIELD PRIOR TO SHOP DRAWINGS. REFER TO SIGN LOCATION PLAN AND MESSAGE SCHEDULE FOR SIGN TYPES AND LOCATIONS.

Client/Project Western Michigan University Signage Bid Document		Project No. 14WMU249001
Date 12.12.16	Revisions	Scale As noted

PERFORMANCE SPECIFICATIONS

4.6

H Concrete

- 1 All concrete footers are to be poured in place.
- 2 All concrete footers are to be poured from thoroughly mixed and agitated concrete in order prevent unreasonable voids in the finished casting.
- 3 Concrete to meet specified “PSI Test” for strength: 3,500 psi minimum.
- 4 Concrete to meet specified “Slump test” before pouring footing.
- 5 All footings to extend past the frost line.
- 6 Any footers or posts for signs will be placed in wet concrete and allowed to fully cure in place before any signage is attached or mounted to it in any way.
- 7 Finish: All exposed faces of concrete shall receive a finish to match existing, adjacent surfaces.

I Construction Adhesives

- 1 **Acrylic and light aluminum panels** - VHB tape
Very high bond acrylic tape for bonding metals and plastics. VHB can be used on both finished and unfinished surfaces.
Prepare surface by removing grease, loose contaminants and oxidized spots using an isopropanol wipe down no more than fifteen minutes prior to adhesion.
- 2 **Heavy gauge aluminum sheets and components** - Lord 201 Acrylic adhesive
Two-part acrylic structural adhesive for bonding metals and plastics. Series 201 can bond both finished and unfinished surfaces.
Two-part acrylic structural adhesive should only be used in addition to mechanical fastener.
Prepare surface by removing grease, loose contaminants and oxidized spots.
Apply by spraying rolling or brushing on single surface to produce bond lines 5-10 mils thick and both surfaces to produce 25-50 mils thick.
Use Lord spec charts to determine correct accelerator process.

J Adhesive tape

Closed-cell foam type with adhesive surfaces on both faces. Thicknesses and widths of tapes shall be as required to safely secure signs to various wall finishes, but in no case shall be less than 1/16 inch thick and 1/2 inch wide. Adhesive tape shall be equal to Norton Sealant Tape No. 1001 Series.

K Liquid adhesive: Silicone Silastic 732 RTV adhesive/sealant as manufactured by Dow Corning.

L Extruded polycarbonate sheet: Polished on both surfaces. Notched Izod impact strength of 12 to 16 ft.-lbs. per inch per ASTM D-256 Elongation % of 100 per ASTM D-638 Modulus of elasticity (psi) of 345,000, per ASTM

D-638 Heat deflection temperature of 270°F @ 264 psi, per ASTM D-648

M Acrylic: cast acrylic sheet, in thicknesses and colors specified. Flame polish exposed edges. Exposed edges must be free of saw marks.

N LED lighting:

- 1 High efficiency, long life series parallel lighting system
- 2 Sign housings and frame shall be fully sealed against light leakage.

O Other lighting sources

- 1 Provide all specific call-outs on shop drawings for lamp type, necessary transformers or ballasts and all necessary electrical draws for service installation.
- 2 Locate all transformers on shop drawings. All necessary electrical hardware must be hidden.

P ADA-compliant photopolymer: Sign face: polyamide resin; carrier: polyester, .011 inch thick; photomechanical, monolithic, tactile plaque sign construction. To comply with relevant ADA regulations and requirements indicated for materials, thickness, finish colors designs, shapes, sizes and details of construction. Sign copy to be in relief 1/32 inch minimum from plaque first surface by manufacturer’s photomechanical stratification processes. Precisely formed, crisp, uniformly opaque and chip-resistant graphics to comply with relevant ADA regulations and the requirements indicated for size, style, spacing, content, position, finishes and colors.

Q Extruded polycarbonate sheet: Polished on both surfaces. Notched Izod impact strength of 12 to 16 ft.-lbs. per inch per ASTM D-256 Elongation % of 100 per ASTM D-638 Modulus of elasticity (psi) of 345,000, per ASTM D-638 Heat deflection temperature of 270°F @ 264 psi, per ASTM D-648

R Acrylic: cast acrylic sheet, in thicknesses and colors specified. Flame polish exposed edges. Exposed edges must be free of saw marks.

S Lexan film: General Electric Lexan Velvet Surface, matte second surface 5 mils or .010 inch thick.

2.06 FABRICATION

A Report any discrepancies between drawings, specifications and owner requirements and request direction from owner before proceeding.

B Verify measurements in field as required for work fabricated to fit job conditions. Before starting work, examine adjoining work on which work of this section is in any way dependent for perfect workmanship and fit.

C Make work in ample time not to delay job progress and deliver to job at such time as required for proper coordination. Fabricate work true to line and detail with clean, sharply defined profiles. Finish surfaces smooth unless otherwise specified.

D Do cutting, punching, drilling and tapping required for attachment or other work coming in contact with signage work where indicated.

E Changeability: fabricate signs in such a manner that each of the major mounting components may be removed and replaced with similar components by maintenance personnel, but not by unauthorized personnel.

F Construction: fabricate all joints, corners, miters, etc., with work accurately machined, filed and fitted, rigidly framed together at joints and contact points. Carefully match all work to provide a perfect continuity of lines and design, with metal in contact having hairline joints. Make joints of such character and assembly to be strong and as rigid as adjoining sections. Make exposed joints where joint is least conspicuous. **Corners and sharp edges shall be slightly eased.** All edges shall be finished and free of saw marks.

Allow for expansion and contraction of materials from temperature changes, especially when two materials with different coefficients of expansion are used together.

Detail signs to minimize deflection from snow, ice, water or their own weight.

G Engineering: the system shall be engineered to eliminate buckling of any members, failure at any points, distortions or other damage.

The system shall be engineered to be rigid with minimum deflection and rotation under stress and shall be able to withstand movement, shear and torsional loads.

Exposed areas of signs shall not oilcan. Signs shall be designed as structurally self-supporting units. The suspension systems and substructure shall be designed by the sign manufacturer to perform in accordance with the contract documents.

H Connections and accessories: weights of connections and accessories shall be adequate to sustain and withstand stresses and strains to which they will be normally subjected.

I Sign panels - general

- 1 Surface finish: provide surface finishes that are free from lines, mottling, ridges, variations in color, orange peel, bubbles, pinholes, mottling, crazing, grit and coarse particles. This applies to all methods of fabrication and finishing. Use clear coatings for durability, surface protection, appearance and maintenance.

THIS DRAWING REPRESENTS DESIGN INTENT ONLY. FABRICATOR WILL BE RESPONSIBLE TO VERIFY ALL CONDITIONS IN FIELD PRIOR TO SHOP DRAWINGS. REFER TO SIGN LOCATION PLAN AND MESSAGE SCHEDULE FOR SIGN TYPES AND LOCATIONS.

Client/Project Western Michigan University Signage Bid Document		Project No. 14WMU249001
Date 12.12.16	Revisions	Scale As noted

- 2 Material: sign panel material is stated in the schedules under "Notes" and/or on drawings.
- 3 Opacity: except for internally illuminated signs, all signs shall have opaque background and opaque graphics.
Note: all colors, especially in the acrylic signs, are to be clear and match references exactly.–Washed out or weak colors will not be accepted.

J Anchors and fastenings

- 1 Mechanical
 - a Provide anchors and fasteners required to secure work in place.
 - b Surface finish: do not expose fastenings on surface of sign panels unless specifically noted otherwise. Do not deform, distort or discolor sign face surfaces by attachment of concealed fastenings.
 - c Corrosion resistance: all fastenings shall be non-corrosive and resistant to oxidation or other corrosive action, of the same composition completely through their cross sections, particularly when used below grade. Use highest quality stainless steel hardware and fasteners.
 - d Anchors, inserts or fasteners shall be compatible with sign materials, shall not result in galvanic action or chemical interaction of adhesives and shall have demonstrable and sufficient strength for intended use.
 - e Steel anchors and fastenings for exterior use shall be galvanized in accordance with ASTM A153.
 - f Stability: fabricate and install signs with fastenings to withstand all actions imposed by use; 30 psf wind perpendicular to surfaces, water, ice, snow loads and similar forces.
 - g Anchor bolts in concrete shall be cast in place. Manufacturer shall furnish instructions for the setting of anchors and bearing plates. Manufacturer shall ascertain that the items are properly set during the process of the work.
 - h Color: secure work with fastenings of same color and finish as the components they secure where they are exposed to view, unless noted otherwise.
 - i Security: All exposed fasteners must be vandal resistant and have vandal-proof "spanner" type slots to be removed only with a special driver head.

K Messages

The fabricator is responsible for the message layout of all directional message panels. Fabricator must produce scale drawings of message layouts for review prior to fabrication. Layout spacing and letter heights to be based on typical layout guideline drawing pages.

- 1 Layout: layouts are shown on the drawings. All messages including braille shall be flush left, unless noted otherwise. Correct line breaks are indicated in the "Message" column of the schedule and should be followed exactly. **Any problems in message layout shall be brought to the attention of the owner for solution.**
- 2 Fabrication: execute all signs such that letter forms are true and clean. Letter forms with rounded corners, or chipped, nicked, cut or ragged edges, will not be accepted. This applies to all methods of fabrication and copy application.
- 3 Copy: message copy on detail drawings is for layout purposes only. Actual copy is listed in the "Message" column of the schedule. Certain copy may be provided later by the owner.
- 4 Capitalization: directions for upper and lower case are found in the "Message" column of the schedule must be followed exactly.
- 5 Single or double faces: all signs that are double sided will be noted as such in the drawings and message schedule. For double sided signs, the message will be indicated as "Side A" and "Side B" or "Side C" and "Side D".

L Surface-applied messages

- 1 Reflectivity and specular gloss
 - a Non-reflectorized message: 60 degree specular in accordance with ASTM Test D523.
- 2 Thickness: as indicated in specifications herein.
- 3 Color and color fastness
 - a Exposed surfaces and finishes shall show no discernible color change or chalking when exposed for 1,000 hours in an Atlas Twin Arc Weathermaster Model HCDL-X, or equivalent, when tested in accordance with ASTM D822.
- 4 Interletter spacing: follow examples in drawings. Show sample interletter and interword spacing in sample submissions as specified.
- 5 Layout: positions for all messages, symbols, arrows, lines, etc., for all signs are clearly indicated on the drawings and shall be complied with.
- 6 Artwork: contractor shall be responsible for all final reproduction artwork for all messages, symbols, arrows and restroom floor plan drawings.
- 7 Fabrication:
 - a Screened messages: execute all silkscreen printing in such a manner that all edges and corners of finished letter forms are true and clean. Letterforms, color areas or lines with rounded corners, edge buildup or bleeding, sawtoothing, etc., will not be accepted. Execute all silkscreening from photo-screens prepared from typesetter's reproduction of the copy specified. Typesetter's reproductions

- shall be no smaller than 75% of the actual size specified. All above work is included in this contract. Hand cut screens will not be acceptable.
- b Die-cut messages: die-cut, pre-spaced, pre-aligned messages (numbers, words, phrases and arrows) from 3.0 mil flexible film coated with continuous adhesive pressure sensitive backing to meet characteristics specified for surface-applied messages. Execute die-cutting in such a manner that all edges and corners of finished letter forms are true and clean. Letter forms with round positive or negative corners, nicked, cut or ragged edges, etc., will not be acceptable.

M Illuminated signs

- 1 All means of internal illumination for signs shall be positioned in accordance with the copy layout to provide even light distribution to the copy.
- 2 Fabricator must apply diffuser materials as necessary to eliminate hot spots created by the illumination (especially with LED signs).
- 3 All exterior fixtures and those in wet-damp locations shall be fitted with seals and gaskets to form a weatherproof, watertight assembly and shall be of rust resistant construction and finish.
- 4 LED illumination:
 - a Provide all step-down transformers and connection devices necessary for electrician to connect to service
 - b Hide any external connections or J-boxes within the structure of the sign.
- 6 Provide emergency shut-off switches on exterior of sign, per UL regulations.
- 7 Provide photo-cell device hidden near the sign face to automatically switch the sign on and off
- 8 Encase all electrical wiring in flexible metal conduit or metal raceways. Hide raceways from view. Tie into BAS where applicable.

THIS DRAWING REPRESENTS DESIGN INTENT ONLY. FABRICATOR WILL BE RESPONSIBLE TO VERIFY ALL CONDITIONS IN FIELD PRIOR TO SHOP DRAWINGS. REFER TO SIGN LOCATION PLAN AND MESSAGE SCHEDULE FOR SIGN TYPES AND LOCATIONS.

Client/Project Western Michigan University Signage Bid Document		Project No. 14WMU249001
Date 12.12.16	Revisions	Scale As noted

PERFORMANCE SPECIFICATIONS

4.8

3.01 Inspection

- A Examine the substrates and conditions under which the signs are to be installed and notify the owner in writing of conditions detrimental to the proper and timely completion of the work. Do not proceed with the work until unsatisfactory conditions have been corrected.
- B An Electrical permit will need to be acquired from the State of Michigan.

3.02 Installation

- A **Install sign units and components with concealed fasteners, unless otherwise shown.** Refer to detail drawings for general method. Verify each surface in filed to determine specific, appropriate hardware.

Drawings in this package may not indicate any below-ground or in-wall structural tie-ins or connections that may be necessary to assure stable and secure installation of signs. Sign fabricator is responsible for determining where such connections are necessary and for coordinating with related trades to make them.

- B **Locations:** refer to drawings for approximate locations. Any discrepancies or apparent deviations from drawing locations because of different site conditions shall be brought to the attention of the owner for solution. The owner must be present for field placement of sign.

It shall be the responsibility of the Contractor to determine the location of underground structures and utilities by the use of test pit excavation prior to excavation operations.

Test pits shall be of the size, depth and location as approved by the Engineer. Each pit shall be tamped backfilled.

Test pit excavation will be measured on the basis of the volume of material actually removed from within the limits specified. Tamped backfill will not be measured but shall be included in the price bid for test pit excavation.

Price provided shall include all excavation, tamped backfill, labor, tools, equipment and incidentals necessary to complete the installation of each sign.

- C **For ground-mounted signs, provide whatever replacement concrete, pavers, bricks, etc. are necessary to match adjacent surfaces exactly.** Seams should be parallel or perpendicular to sign face and be symmetrical around post(s).

- D **Note that this institution experiences heavy public use.** Challenging environmental conditions such as inclement weather, theft and vandalism will be routine problems. Signs must be securely mounted. Contractor is responsible for suggesting alternative fabrication or installation methods if required to prevent theft or vandalism.

- E **Install signs to be level, plumb and at the proper height.** Cooperate with other trades for installation of sign units.

- F **Clean and polish, remove excess adhesive.**

G Fixture installation

- 1 Install lighting fixtures with seals and gaskets. Conceal all wiring in or within the construction.
- 2 Lamp installation
 - a Do not install lamps for permanent use until operating voltage is verified and established.
 - b Install lamps in accordance with lamp and fixture manufacturer's instructions.
- 3 Ballast installation
 - a Install ballasts at factory unless specifically indicated otherwise. Mount on rubber grommets or sound isolating details to reduce noise transmission.

3.03 Cleanup

- A Periodically (at least daily) and upon completion of the installation, remove all waste, dirt, wrappings and excess materials, tools and equipment, and carefully and thoroughly clean all surfaces to the satisfaction of the owner.

3.04 Property Damage

- A Protect all adjacent surfaces from damage and pay the cost of repairing any damage to the property caused by delivery or installation of materials. In all cases, match existing surfaces.

THIS DRAWING REPRESENTS DESIGN INTENT ONLY. FABRICATOR WILL BE RESPONSIBLE TO VERIFY ALL CONDITIONS IN FIELD PRIOR TO SHOP DRAWINGS. REFER TO SIGN LOCATION PLAN AND MESSAGE SCHEDULE FOR SIGN TYPES AND LOCATIONS.

Client/Project Western Michigan University Signage Bid Document		Project No. 14WMU249001
Date 12.12.16	Revisions	Scale As noted

Section 6 **Appendix I**

Product specifications



Doc# 1001
WWW.DLC-LUMISHEET.COM

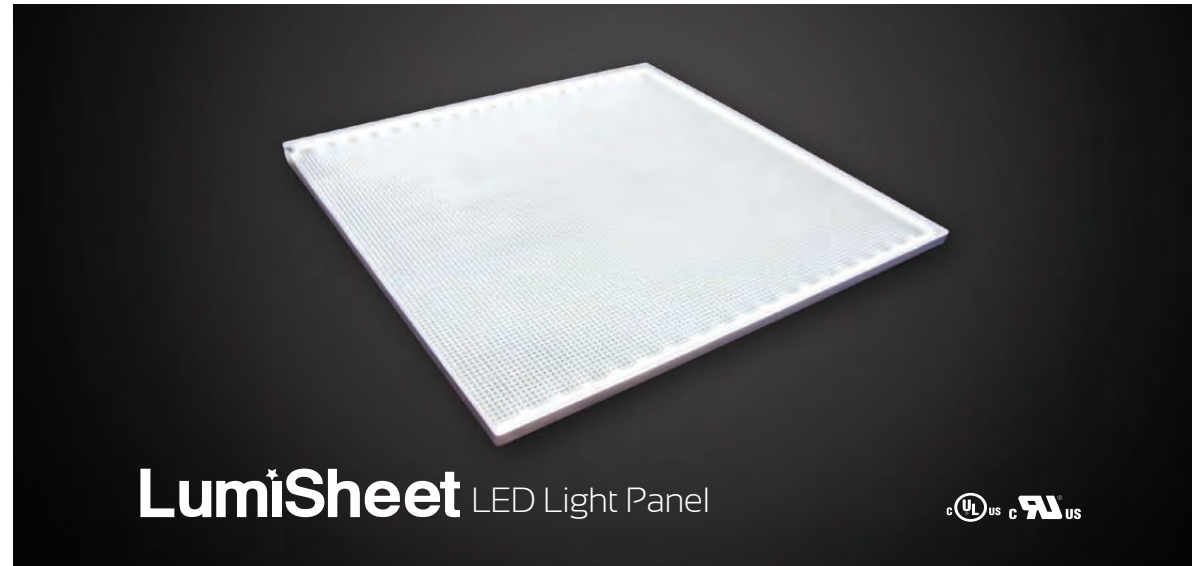

LumiSheet LED Light Panel

The LumiSheet is designed to emit a bright, even output of light across the entire surface of the panel. Unlike traditional light panels, which have the light source mounted on the exterior of the LGP (Light Guide Plate), LumiSheet integrates high brightness LEDs and heat sink into our exclusive 3D V-cutting LGP which makes it possible to produce "frameless", rectangular or special shaped LED light panels for various application needs.

Features

- AVAILABLE IN CUSTOM SIZES & SHAPES
- CAN BE USED IN "FRAMELESS" DESIGNS
- 3D V-CUTTING TECHNOLOGY
- HIGH BRIGHTNESS (2,000 - 10,000 LUX)
- PATENTED HEAT SINK TECHNOLOGY TO MAXIMIZE LED LIFESPAN (70,000 HOURS)
- LOW POWER CONSUMPTION (70% LESS THAN FLUORESCENT)
- ENERGY SAVING AND MAINTENANCE FREE
- SUPERIOR CONSISTENT LIGHT QUALITY
- ADVANCED 3-YEAR WARRANTY



1-866-766-0509 | 1-905-474-0555 | RFQ@DLC-LUMISHEET.COM



Doc# 1001
WWW.DLC-LUMISHEET.COM

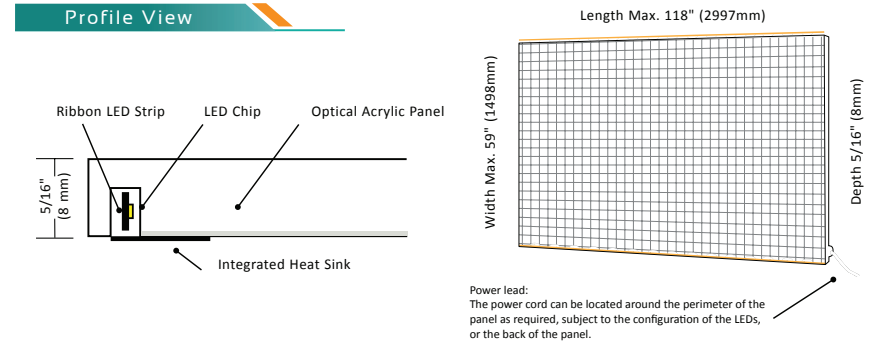

Specification					
Electrical					
Input Voltage	12 VDC				
Power Consumption	4.0 Watts/ft (Standard)				
Wire Size	20 AWG 2 wire				
Wiring	Each panel must have direct connection to power supply. Do not wire panels in series				
Connector	2.1/5.5mm barrel plug. Standard 5' (1500mm), Optional 10' (3000mm)				
Certification	UL / cUL (E346146) listed, UL/cUL (E362079) recognized components for signage				
Physical					
Color Temperature	3000K	3500K	4100K	5300K	6300K
Mounting	Wall mounted with screws, Z-clips, U-channel, or mirror clips (refer to Mounting Options - Page 47)				
Operating Temperature	- 30 °c (- 22 °F) ~ + 40 °c (+ 104 °F)				
Environment	Dry location only				
Thickness	5/16" (8mm)				
Minimum Size	2"W x 2"L (50mm x 50mm)				
Maximum Size	59"W x 118"L (1499mm x 2997mm)				
Weight	1.95 lbs /sq. ft. (9.54 kg/sq. M)				

Order Information					
Series #	Size Length x Width (inch/mm)*	Color Temp	Illuminated Face Option	Cable Length	LED Location
LLP 12 8mm 12V	CS - Custom shape (drawing may be required)	- 3000K - 3500K - 4100K - 5300K - 6300K	- SFI - Single Face* - DFI - Double Face	- WL15 - 5' (1500mm) power cord with 2.1/5.5mm barrel plug* - WL30 - 10' (3000mm) power cord with 2.1/5.5mm barrel plug	- L1 - LED along 1 long edge - L2 - LED along 2 long edges* - S1 - LED along 1 short edge - S2 - LED along 2 short edges - S4 - LED along All 4 edges - CI - Custom Illumination

*Acrylic and other manufacturing components and methods may contribute to an expansion or contraction of sizes based on environmental or tooling factors. Please allow a minimum of ± 1/8" (3.175mm) to compensate for any changes in the outside dimensions of this product.

*DLC strives to maintain tight control over specification factors. However specifications are subject to change on rare occasion and may not be reflected in the catalogue.

1-866-766-0509 | 1-905-474-0555 | RFQ@DLC-LUMISHEET.COM

THIS DRAWING REPRESENTS DESIGN INTENT ONLY. FABRICATOR WILL BE RESPONSIBLE TO VERIFY ALL CONDITIONS IN FIELD PRIOR TO SHOP DRAWINGS. REFER TO SIGN LOCATION PLAN AND MESSAGE SCHEDULE FOR SIGN TYPES AND LOCATIONS.

Client/Project		Project No.
Western Michigan University Signage Bid Document		14WMU249001
Date	Revisions	Scale
12.12.16		As noted



Doc# 1001
WWW.DLC-LUMISHEET.COM

LumiSheet (Specifications by Size)				
Size (inch)	Size (mm)	LED Strip	*Average Surface Brightness (Lx)	Power Consumption (W)
6 x 6	150 x 150	1 side	6,000	2.0
12 x 12	300 x 300	1 side	3,000	4.0
24 x 24	600 x 600	2 sides	3,200	15.0
36 x 36	900 x 900	2 sides	2,600	23.0
48 x 48	1200 x 1200	2 sides	2,200	30.0
48 x 96	1200 x 2400	2 sides	2,200	60.0
Ø 6	Ø 152	all around	19,000	5.8
Ø 12	Ø 300	all around	13,000	11.2
Ø 24	Ø 600	all around	5,400	24.0
Ø 36	Ø 900	all around	4,500	36.0
Ø 48	Ø 1200	all around	3,500	48.0

**Brightness data was measured Jan, 2015.*

Typical Surface Brightness Measure

24" x 48" LumiSheet with 5300K LEDs lit along 2 long edges (30W)

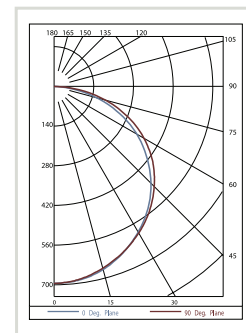
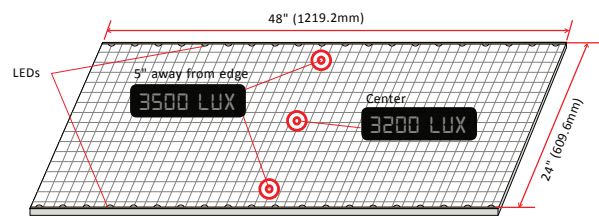

12" x 12" panel with 5300K LED lit along 2 edges (8W)

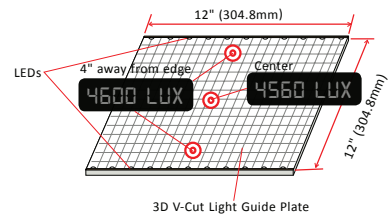

48" x 96" LumiSheet with 5300K LEDs lit along 2 long edges (60W)

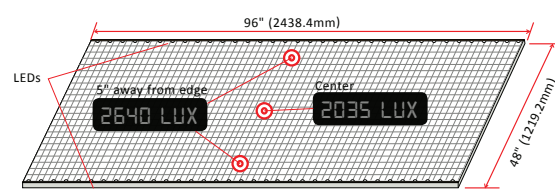

*Brightness readings are for reference only. Actual reading may differ for different LEDs, LGPs or even different meters.

1-866-766-0509 | 1-905-474-0555 | RFQ@DLC-LUMISHEET.COM

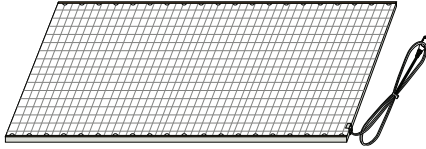
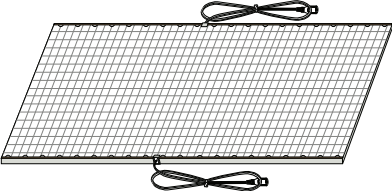
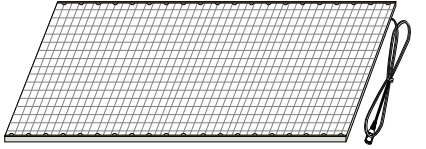
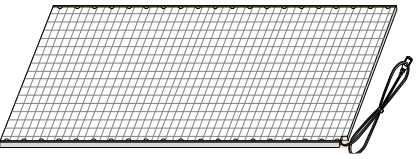

Doc# 1001
WWW.DLC-LUMISHEET.COM

Typical Power Cord Exits	
Standard 1  Power cord exits from short side (edge) corner (standard)	Standard 2  Power cord exits from the middle of each long side for LumiSheet longer than 6 ft
Option 1  Power cord exits from the back side of LumiSheet	Option 2  Recessed (notched) power cord exits

LumiSheet - Surface Mounting Options (Mounting accessories are sold separately)

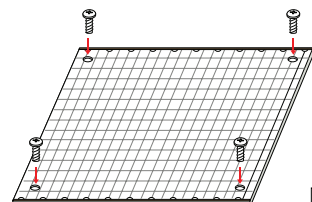
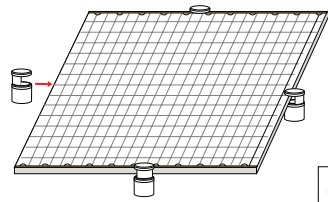
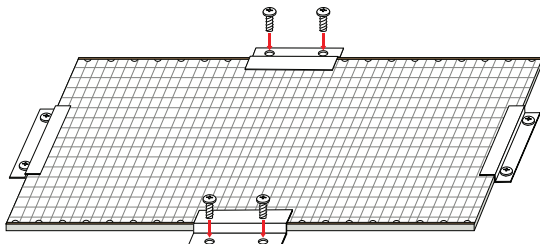
Option 1: Screw mounting with pre-drilled holes  *Holes can be drilled at factory according to drawings supplied.	Option 2: Mounting with Standoffs 
Option 3: Mounting with Z clips 	

1-866-766-0509 | 1-905-474-0555 | RFQ@DLC-LUMISHEET.COM

THIS DRAWING REPRESENTS DESIGN INTENT ONLY. FABRICATOR WILL BE RESPONSIBLE TO VERIFY ALL CONDITIONS IN FIELD PRIOR TO SHOP DRAWINGS. REFER TO SIGN LOCATION PLAN AND MESSAGE SCHEDULE FOR SIGN TYPES AND LOCATIONS.

Client/Project Western Michigan University Signage Bid Document		Project No. 14WMU249001
Date 12.12.16	Revisions	Scale As noted

APPENDIX

5.4

Note:
ST30 & St 33 Use the Daktronics Galaxy model.

All other signs with a digital LED screen use the Mega Sign Premier model.

For additional information, contact:
Mega Sign, Inc.
Dan Soriano
daniel@megasigninc.com
213.222.4194

Daktronics
Ryan Stratton
ryan.stratton@daktronics.com
586.850.2113

THIS DRAWING REPRESENTS DESIGN INTENT ONLY. FABRICATOR WILL BE RESPONSIBLE TO VERIFY ALL CONDITIONS IN FIELD PRIOR TO SHOP DRAWINGS. REFER TO SIGN LOCATION PLAN AND MESSAGE SCHEDULE FOR SIGN TYPES AND LOCATIONS.

Client/Project		Project No.
Western Michigan University Signage Bid Document		14WMU249001
Date	Revisions	Scale
12.12.16		As noted



Quotation Number: 150-0711-2
Prepared For:

Quotation Date: 7/11/2016
Project Name:
Prepared By: Daniel
Quote Valid: 7/31/2016

Quotation Summary

**Includes Free Custom Graphics Package:
36 Custom Designed Static Graphics
(3 per month for 1 year)**

Accessories / Communication

Digital Temperature Probe Included
Auto Dimming Sensor Included
Wireless Communication Normal Range

Electrical Requirements (per face)

Regular Operating Watts: 1355
Total Boot Up Watts: 4516
Regular Operating Amps: 11.3
Boot Up Amps: 37.6
AC Power Required: 120

Display Specification

Series Mega HD
Model: P1677Real
Color: Full Color
Pixel Matrix: 140 x 140
Resolution: 16mm
Cabinet Dimension 7ft 6in x 7ft 6in
Display Dimension 7ft 4in x 7ft 4in
Total Weight (lbs) 506
Maintenance: Front Module Access
Minimum Character Height: 4.4 inch
Maximum Character Height: 87.19 inch

LED / Pixel Specification

LED Pixel Pitch 16mm
Brightness: 13,000 NITS
Viewing Angle: 160H/ 120V
LEDs Per Pixel: 1R,1G,1B

Term of Purchase

FOB: Los Angeles
Warranty: 5 Year Parts Warranty
Deposit: 50% Deposit
Balance Due: 50% Prior to Shipment
Delivery < 4 Weeks

S4 Premier SERIES FULL COLOR
MODEL # P1677REAL

Model #	Pixel Matrix	Module Matrix	Frame Size
P1677REAL	140 x 140 px	7 x 7	7ft 6in x 7ft 6in



Top



Double Faced ↔



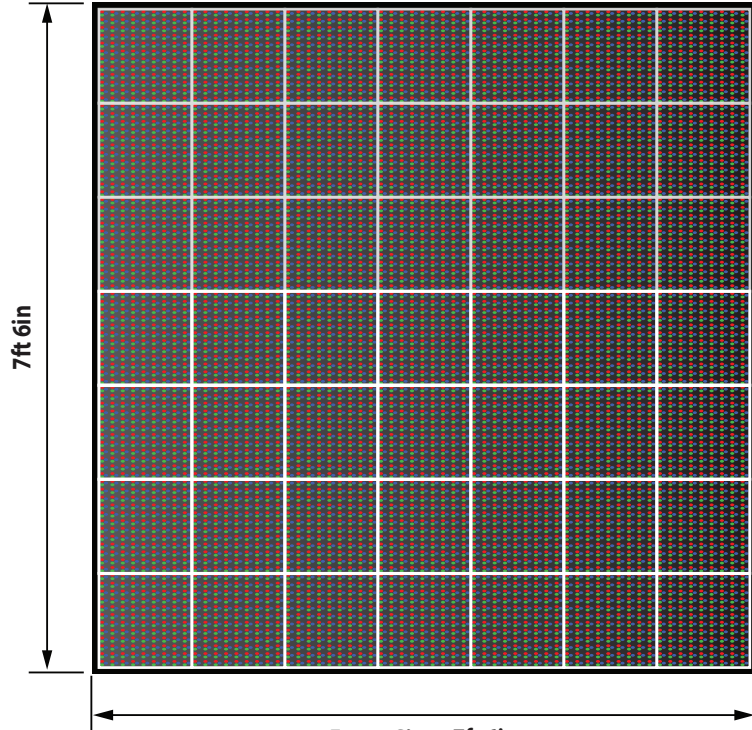

Front

Frame Size 7ft 6in

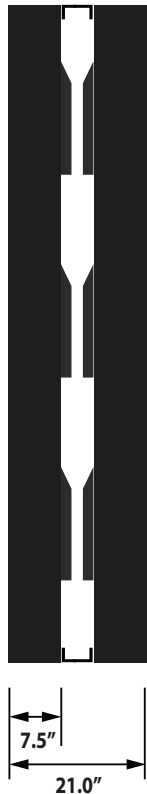

Back

7.5" | 21.0"

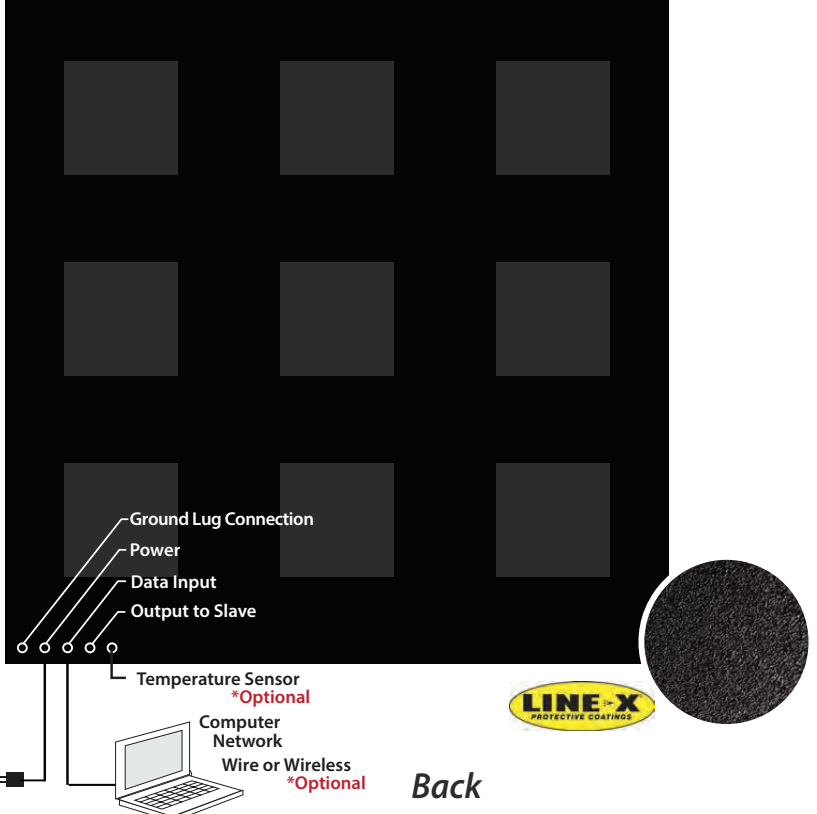

Ground Lug Connection
 Power
 Data Input
 Output to Slave
 Temperature Sensor *Optional
 Computer Network Wire or Wireless *Optional



In this age of technology, digital LED signs are becoming more and more paramount to the success of business advertising. With our MEGA LED DISPLAY, you have the ability to display ultra sharp text, images, and videos to engage and capture the attention of onlookers. Designed and engineered in our California facilities, you can expect the highest quality out of the MEGA LED DISPLAY : weather proof structure, aluminum body, energy efficiency, conformal coated power supplies, and only the top quality LEDs for vibrant colors and extended lifeline. * Picture may be different than actual product! This is a reference guide only!

THIS DRAWING REPRESENTS DESIGN INTENT ONLY. FABRICATOR WILL BE RESPONSIBLE TO VERIFY ALL CONDITIONS IN FIELD PRIOR TO SHOP DRAWINGS. REFER TO SIGN LOCATION PLAN AND MESSAGE SCHEDULE FOR SIGN TYPES AND LOCATIONS.

Client/Project Western Michigan University Signage Bid Document		Project No. 14WMU249001
Date 12.12.16	Revisions	Scale As noted

MEGA SIGN, INC. MEGA LED TECHNOLOGY 6500 Flotilla st. Commerce CA 90040 TOLL FREE : 888.315.7446 TEL : 213.746.7445 FAX : 213.764.7442 info@megasigninc.com	Title <h3 style="text-align: center;">Model# P1677REAL</h3>	Electrical <h3 style="text-align: center;">1355 Max Watts - 11.1 Amps at 120 Volts</h3>	
	Date <h3 style="text-align: center;">7 / 11 / 2016</h3>	Drawn by <h3 style="text-align: center;">Philip K.</h3>	



Innovative LED Display Solution Since 2006



Innovative LED Display Solution Since 2006



• *Designed and Built in the USA*

Our experienced fabricators, designers, and management team take great pride in delivering quality in every display we build in our 69,000 square foot factory in Commerce, CA.



• *Five Year Parts and Factory Labor Warranty*

We stand behind everything we build. That's why we offer an industry-leading 5-year parts + factory labor warranty with an optional on-site labor warranty.

• *Built to Last*

With oversized rain hoods on vents, built in surge suppression, EMI filters, front & rear waterproof LED modules and data connectors, LINE-X coating, solid state control systems, waterproof plugs, and DELTA power supplies that are 40% more heat tolerant, your sign is going to look and perform just like the day you bought it for years to come.

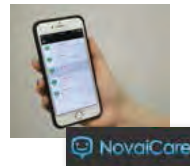

• *Tons of Customizations*

Need something tiny and simple? Big and robust? We've got you covered. MEGA offers a huge array of display sizes, shapes and resolutions to perfectly match your needs.



• *Price Match Guarantee*

We offer a price match guarantee. One of our competitors quoted you a better price? Send it to us and we'll match it.

* The price match guarantee is limited to products manufactured in the United States that are UL / MET certified. The product must be comparable or identical in size, pitch, brightness, and cabinet material with a 5 year manufacturer's warranty. MEGA SIGN Inc. does not price match any products that are manufactured outside of the United States, constructed with a steel cabinet, refurbished or used, quoted with discounts, incentives, installation costs, coupons, promotions, or 3rd party marketplace prices. The price match guarantee is only valid for pre-production quotes. If these conditions are not met, Mega Sign Inc. reserves the right to waive the price match guarantee.



• *Toll Free Support - for Life*

We take care of our customers, and we'll never leave you hanging out to dry. When you buy a MEGA LED product, you're automatically entitled to support for the entire life of that sign. For free.

THIS DRAWING REPRESENTS DESIGN INTENT ONLY. FABRICATOR WILL BE RESPONSIBLE TO VERIFY ALL CONDITIONS IN FIELD PRIOR TO SHOP DRAWINGS. REFER TO SIGN LOCATION PLAN AND MESSAGE SCHEDULE FOR SIGN TYPES AND LOCATIONS.



Client/Project		Project No.
Western Michigan University Signage Bid Document		14WMU249001
Date	Revisions	Scale
12.12.16		As noted

06

07

OUR PRODUCTS



Versa LED DISPLAY

Communicate to your prospects as they pass by with VERSA, our scrolling indoor / outdoor display that's easy to work with, built to last and priced just right.

- Thin & Lightweight
- Low Energy Consumption
- Indoor / Outdoor
- 1 year Warranty



Premier LED DISPLAY

Our premium outdoor display, crafted with the perfect blend of rugged durability, unparalleled flexibility and visual precision.

- High Definition
- Capable of Supporting Any-size
- Outdoor
- 5 year Warranty



SMD LED DISPLAY

Our ultra high-resolution indoor display, designed and built with one goal in mind—to make your organization or event shine.

- Ultra High Resolution
- Live Streaming Video
- Indoor / Outdoor
- 3 year Warranty

INTRODUCTION TO PREMIER

Bright, bold, and built to last, PREMIER commands attention—which means more visitors and more customers.



20mm, 6ft 6in x 15ft 1in
Indiana, PA
www.megasigninc.com



THIS DRAWING REPRESENTS DESIGN INTENT ONLY. FABRICATOR WILL BE RESPONSIBLE TO VERIFY ALL CONDITIONS IN FIELD PRIOR TO SHOP DRAWINGS. REFER TO SIGN LOCATION PLAN AND MESSAGE SCHEDULE FOR SIGN TYPES AND LOCATIONS.

Client/Project		Project No.
Western Michigan University Signage Bid Document		14WMU249001
Date	Revisions	Scale
12.12.16		As noted

SPECIAL FEATURES — THE MEGA DIFFERENCE

You can't build a quality LED sign without quality components. Let us show you how our attention to detail translates to the real world and helps bring you more business.

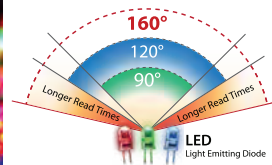

· High Quality LEDs
: We use better LED chips which means MEGA LED signs degrade slower than usual for long lasting brightness, consume less power for more efficiency, and have a wide viewing angle for longer read times.



· High Contrast Modules
: Our modules faces are made from the highest quality polycarbonate, and are meant to resist warping, cracking and fading in even the harshest weather conditions with a dark matte black finish that creates a better contrast for sharper images.



- NEW EXCLUSIVE MEGA TECHNOLOGY -
· Fully Encapsulated in Silicone
: Our modules are IP67 rated in the front and IP65 rated in the back for complete protection from dust, water, and humidity.



- NEW EXCLUSIVE MEGA TECHNOLOGY -
· Water Proof IP 65 Connectors
: Water proof data and power connectors to increase connectivity and reliability even in the wettest conditions.



- NEW EXCLUSIVE MEGA TECHNOLOGY -
· Upgradable Modules
: With Premier you'll never be stuck wishing you would have gone with a higher resolution. Whatever pixel pitch you choose now, you can always upgrade later. Just purchase the new panels, pop off the old ones, and you're good to go.

SPECIAL FEATURES — THE MEGA DIFFERENCE



· Quick Release Modules
: Four Quick release 90° turns with an allen key to replace our modules, that's it.



· All Aluminum Cabinet
: Aluminum is lighter than iron cabinets, and it resists corrosion much better too—keeping your sign safe and sound through the years.



· Line-X Coating
: We're not done yet—LINE-X coatings seal in our signs to keep all the weather outside, where it belongs.



· Conformal Coated Power Supplies
: Conformal coating extends the life of our power supplies, keeping our signs lit longer than our competitors. Rated for high heat tolerance up to 140°.

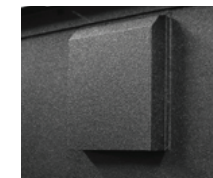

· Oversized Rain Hoods
: With 12" tall oversized rain hoods, rain water doesn't stand a chance to penetrate our cabinets even in strong winds.



· Surge Suppression & EMI Filters
: Built in surge suppressors will protect all the sensitive electronic components while EMI filters will reduce any potential electromagnetic noise for a trouble-free display.

THIS DRAWING REPRESENTS DESIGN INTENT ONLY. FABRICATOR WILL BE RESPONSIBLE TO VERIFY ALL CONDITIONS IN FIELD PRIOR TO SHOP DRAWINGS. REFER TO SIGN LOCATION PLAN AND MESSAGE SCHEDULE FOR SIGN TYPES AND LOCATIONS.



Client/Project		Project No.
Western Michigan University Signage Bid Document		14WMU249001
Date	Revisions	Scale
12.12.16		As noted

VIEWING DISTANCE

The distance between pixels is called pitch. Our higher resolution signs use PHYSICAL PITCH resolution measurements, meaning the pixels on the display are an accurate representation of the pixels in your original source image. However our 20mm pitch uses even array 4 LED distribution to produce 10mm virtual pixels.

The end result is a display with high pixel density, with text, videos and animations with incredibly vivid color depth and brightness. Pixel pitch is very important for how well your sign performs—check below for the ideal pitch for each viewing distance.



MODULE COMPARISON

Here's a more detailed guide to help you pick the best PREMIER display for your needs:

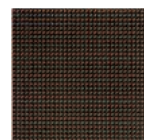

PREMIER 10MM

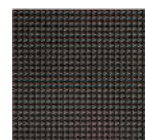

PREMIER 13.3MM



PREMIER 16MM



PREMIER 20MM / 10MM VIRTUAL
(4 LED EVEN ARRAY)

	PREMIER 10MM	PREMIER 13.3MM	PREMIER 16MM	PREMIER 20MM / 10MM VIRTUAL (4 LED EVEN ARRAY)
Pixel Composition	1 Red, 1 Green, 1 Blue	1 Red, 1 Green, 1 Blue	1 Red, 1 Green, 1 Blue	2 Red, 1 Green, 1 Blue
Brightness	> 9,000 NITS	> 11,000 NITS	> 13,000 NITS	> 10,000 NITS
Letter Size	3" Minimum	4.5" Minimum	5" Minimum	6" Minimum
Best Use	All Type of Contents	Pictures, Video, Text	Pictures, Animation, Video, Text	Animation, Pictures, Text
Minimum Viewing Distance	25 + feet	50 + feet	60 + feet	80 + feet
Optimal Viewing Distance	100 +	120 +	150 +	155 +

* More pixels provide better resolution display.

SOFTWARE — COMMAND CENTER OF YOUR SIGN

LED sign software is extremely important, which is why we designed ours to make your life as simple as possible. Now, anyone can program an LED sign without spending hours on the phone with tech support.

· XM Player Express (for VERSA, PREMIER, SMD)

Create eye-popping text, animations, graphics and videos for your sign in just a few (simple) steps. The software is built to be easy and fun to use, so you can get back to your business ASAP.



· Nova Star Cloud (for PREMIER, SMD)



- **Total Control:** Program and display new content from anywhere. Set up in-depth scheduling based on times, days, and even regions across your whole fleet of LEDs.



- **24/7 Monitoring:** System diagnostics, computer status and sign functionality are all monitored around the clock—and available at your fingertips.



- **Rich Multimedia Support:** Video, audio, flash, Office documents, weather forecasts, countdowns, streaming media, websites...you get it. The possibilities are almost limitless.



- **Quadruple-Layered Security:** Nova Cloud locks down your data tighter than Fort Knox using file fingerprints, HTTPS/FTL/SSL encryption, terminal registration and lockdown, and DVI encryption.



- **It's Just Easy:** Nova Cloud makes it insanely simple for you to get started right away without getting bogged down in cumbersome computer programs. Stop wasting time and start advertising!



THIS DRAWING REPRESENTS DESIGN INTENT ONLY. FABRICATOR WILL BE RESPONSIBLE TO VERIFY ALL CONDITIONS IN FIELD PRIOR TO SHOP DRAWINGS. REFER TO SIGN LOCATION PLAN AND MESSAGE SCHEDULE FOR SIGN TYPES AND LOCATIONS.

Client/Project Western Michigan University Signage Bid Document		Project No. 14WMU249001
Date 12.12.16	Revisions	Scale As noted

UNDER THE HOOD

Ready to dive in and see what makes a MEGA LED display?

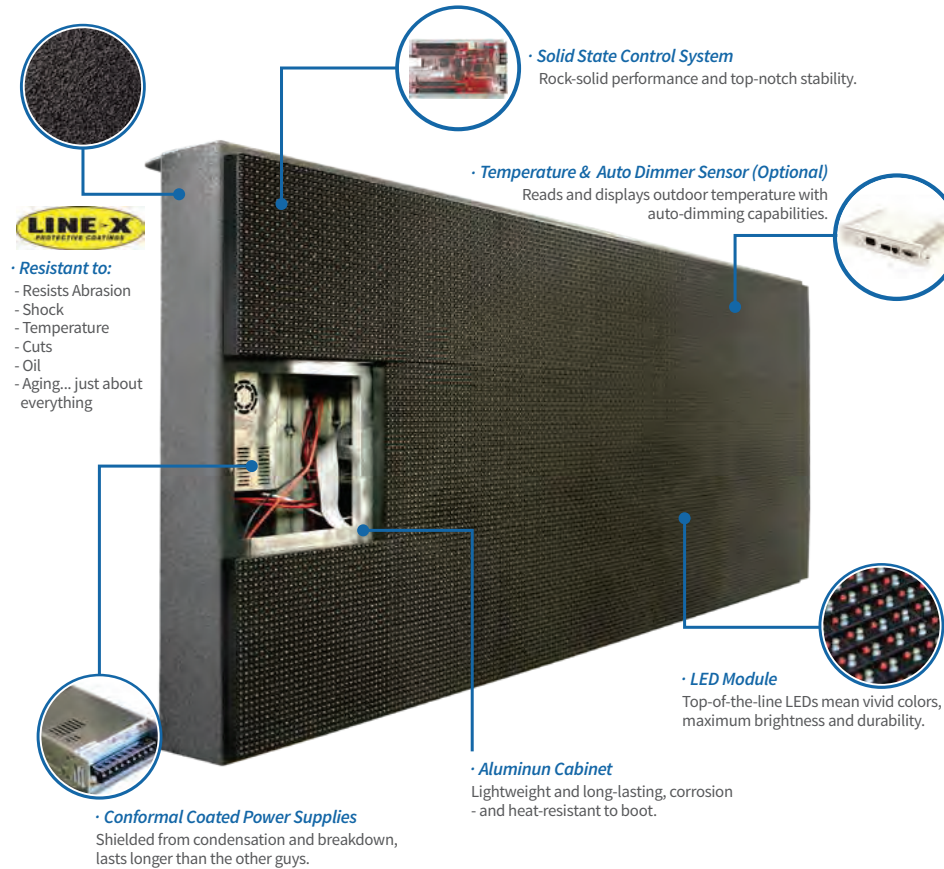

UNDER THE HOOD

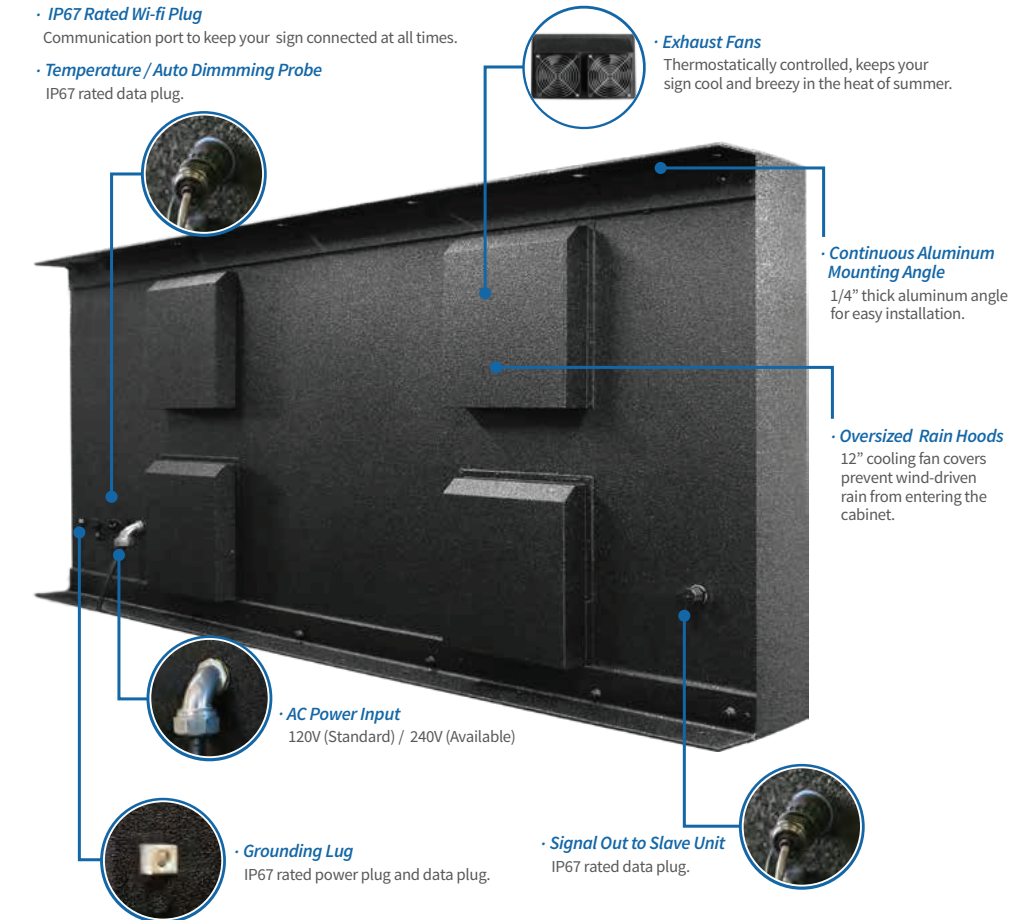

- Product Safety Testing & Certification -
 Met Lab Certified - Compliant with UL Specifications
 (UL 48, UL 8750, UL 1433, CSA - C22.2 NO.207)



THIS DRAWING REPRESENTS DESIGN INTENT ONLY. FABRICATOR WILL BE RESPONSIBLE TO VERIFY ALL CONDITIONS IN FIELD PRIOR TO SHOP DRAWINGS. REFER TO SIGN LOCATION PLAN AND MESSAGE SCHEDULE FOR SIGN TYPES AND LOCATIONS.



Client/Project Western Michigan University Signage Bid Document		Project No. 14WMU249001
Date 12.12.16	Revisions	Scale As noted

MEGA OPTIONAL FEATURES

Manage in your LED display

Communication Options : With many choices for communication we have the right option to suit your needs.

· Wi-Fi Up 1000ft

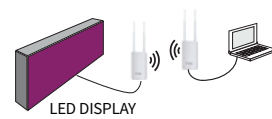

· 3G Cellular Network



· Cat-5 Ethernet Network



· Fiber Optics



Auto Dimming Feature

: With auto dimming capabilities your sign will dim automatically at night reducing power draw to save you money.



Temperature Sensor

: High quality temperature sensor for displaying accurate readings on your display.

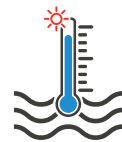

Remote Diagnostic Capabilities

: Remote diagnostic capabilities let you know everything about your displays at anytime and anywhere by continuously monitoring your signs health through the web and IOS or Android smartphone applications.

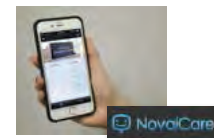

Nova Cloud-Based Software

: Powerful Nova Cloud software provides centralized content publishing, remote monitoring, remote settings, playlist logging, multi-media support and multi-layered security for peace of mind.



INCREASE YOUR BUSINESS STRENGTH

What are the secrets to growing your business? Developing the right strategy in the right market at the right time.

What the Small Business Administration Says about Electronic Message Centers (LED Signs)

Electronic Message Centers are an investment in your business and provide the **best and most cost-effective** forms of paid advertising.

*“With an electronic message display, the owners typically see an increase in business of **15% to 150%**. Using the smaller number, consider the following example.”*

A small business generating \$1,000 a day in revenue adds an electronic message center. The business soon increases by 15%, adding another \$150 per day in total revenue. That translates into an additional \$1,050 a week in revenue, or \$54,600.00 per year.



TRUSTED BY BRANDS EVERYWHERE

From NASA to Toyota, MEGA's LED signs are shining bright all across the country. We're extremely proud of our diverse group of clientele—here are just a few of the wonderful companies we've had the privilege to work with.



THIS DRAWING REPRESENTS DESIGN INTENT ONLY. FABRICATOR WILL BE RESPONSIBLE TO VERIFY ALL CONDITIONS IN FIELD PRIOR TO SHOP DRAWINGS. REFER TO SIGN LOCATION PLAN AND MESSAGE SCHEDULE FOR SIGN TYPES AND LOCATIONS.

Client/Project Western Michigan University Signage Bid Document		Project No. 14WMU249001
Date 12.12.16	Revisions	Scale As noted

Note:

ST30 & St 33 Use the Daktronics Galaxy model.

All other signs with a digital LED screen use the Mega Sign Premier model.

For additional information, contact:

Mega Sign, Inc.
Dan Soriano
daniel@megasigninc.com
213.222.4194

Daktronics
Ryan Stratton
ryan.stratton@daktronics.com
586.850.2113

THIS DRAWING REPRESENTS DESIGN INTENT ONLY. FABRICATOR WILL BE RESPONSIBLE TO VERIFY ALL CONDITIONS IN FIELD PRIOR TO SHOP DRAWINGS. REFER TO SIGN LOCATION PLAN AND MESSAGE SCHEDULE FOR SIGN TYPES AND LOCATIONS.

Client/Project Western Michigan University Signage Bid Document		Project No. 14WMU249001
Date 12.12.16	Revisions	Scale As noted

GALAXY® GS6 15.85 MM PRODUCT SPECIFICATIONS

The GS6 is the best full-feature, high-quality Galaxy series yet. This product provides users a display that runs outstanding graphics and animations using the best contrast in the industry. The 15.85 mm pixel pitch is the highest resolution 16 mm LED display in the industry.

15.85 MM TECHNICAL SPECIFICATIONS

- Character Height:**
4.4" (7 pixel font)
- Line Spacing:**
15.85 mm (0.62")
- Pixel Configuration:**
Monochrome: 1 red or 1 amber
RGB: 1 red, 1 green, 1 blue
- Maximum Brightness:**
Monochrome red: 4,500 nits
Monochrome amber: 6,000 nits
RGB: 12,000 nits
- Monochrome Color Capability:**
4,096 shades of red or amber
- Full Color Capability:**
RGB: 281 trillion colors
- Optimal Viewing Angle:**
140 degrees horizontal x 70 degrees vertical
- Readability Angle:**
160 degrees horizontal x 90 degrees vertical
- Min Viewing Distance:**
37'

PRODUCT FEATURES

- All sealed components
- Quick connects
- Mounting clips
- High-contrast louvers
- Redundant module signal
- Large sections for fast installation
- Front ventilation on displays less than seven feet tall
- No spreader beam required for displays greater than seven feet tall
- Same module size and cabinet size for all pixel pitches
- Single-step module removal
- Shallow cabinet depth
- Narrow cabinet borders

MODEL NUMBER GUIDE

GS6	-	100	x	250	-	15.85	-	RGB	-	SF
Series		Lines High		Columns Wide		Line Spacing		LED Color Red, Amber, or RGB		Single Face or Two View

201 Daktronics Drive PO Box 5128 Brookings, SD 57006-5128
tel 888-325-7446 605-692-0200 ext. 57220 fax 605-692-0381
www.daktronics.com email commercial@daktronics.com
Copyright © 2015 Daktronics DD3148704 Rev01 070116 Page 1 of 8



GS6 SERIES SPECIFICATIONS

- Estimated LED Lifetime:**
100,000+ hours
- Contrast Enhancement:**
Non-reflective black louvers and module face grooves disperse light
- Message Capability:**
Text, graphics, logos, basic animation, video clips, multiple font styles, and sizes
- Control Software:**
Venus® Control Suite
- Power:**
120, 120/240 VAC Single Phase
- Display Dimming:**
64 levels (Automatic, scheduled or manual control)
- Communication Options:**
Ethernet Fiber Optic, Ethernet Bridge Radio, Remote Cellular, Ethernet CAT5
- Operating Temperature:**
-40°F to 120°F with 99% RH non-condensing
- Compliance Information:**
UL and cUL Listed, UL-Energy Verified, FCC compliance
- Warranty Coverage:**
5 years
- Galaxy Product Support:**
Parts support for 10 years

DISPLAY CONFIGURATIONS



Galaxy GS6 LED Screen

GALAXY® GS6 15.85 MM PRODUCT SPECIFICATIONS



5.13

APPENDIX

Lines x Columns	Sections/Ventilated	Cabinet Dimensions Feet-Inches H x W x D	Cabinet Dimensions Meters H x W x D	Cabinet Square Feet (Square Meters)	Active Area Square Feet (Square Meters)	Cabinet Weight Pounds (kilograms)	Lines/Characters per line	Character Height	Maximum Watts		
									Amber	Red	RGB
20x100	Sing/Ft	1'7" x 5'6" x 5"	0.47 x 1.67 x 0.13	8.4 (0.8)	5.5 (0.6)	65 (30)	2/20	4"-12"	255	255	340
20x125	Sing/Ft	1'7" x 6'9" x 5"	0.47 x 2.06 x 0.13	10.4 (1.0)	6.8 (0.8)	75 (35)	2/25	4"-12"	305	305	415
20x150	Sing/Ft	1'7" x 8'1" x 5"	0.47 x 2.46 x 0.13	12.4 (1.2)	8.2 (1.0)	90 (41)	2/30	4"-12"	360	360	485
20x175	Sing/Ft	1'7" x 9'5" x 5"	0.47 x 2.85 x 0.13	14.4 (1.3)	9.5 (1.1)	105 (48)	2/35	4"-12"	410	410	560
20x200	Sing/Ft	1'7" x 10'8" x 5"	0.47 x 3.25 x 0.13	16.4 (1.5)	10.9 (1.3)	120 (55)	2/40	4"-12"	460	460	635
20x225	Sing/Ft	1'7" x 12'0" x 5"	0.47 x 3.65 x 0.13	18.4 (1.7)	12.2 (1.4)	135 (62)	2/45	4"-12"	515	515	705
20x250	Sing/Ft	1'7" x 13'3" x 5"	0.47 x 4.04 x 0.13	20.4 (1.9)	13.6 (1.6)	150 (69)	2/50	4"-12"	565	565	780
20x275	Sing/Ft	1'7" x 14'7" x 5"	0.47 x 4.44 x 0.13	22.4 (2.1)	14.9 (1.8)	165 (75)	2/55	4"-12"	615	615	850
20x300	Sing/Ft	1'7" x 15'11" x 5"	0.47 x 4.84 x 0.13	24.4 (2.3)	16.3 (1.9)	180 (82)	2/60	4"-12"	665	665	925
20x325	Sing/Ft	1'7" x 17'2" x 5"	0.47 x 5.23 x 0.13	26.4 (2.5)	17.6 (2.1)	195 (89)	2/65	4"-12"	720	720	995
20x350	Sing/Ft	1'7" x 18'6" x 5"	0.47 x 5.63 x 0.13	28.4 (2.6)	19.0 (2.2)	205 (93)	2/70	4"-12"	770	770	1070
20x375	Sing/Ft	1'7" x 19'9" x 5"	0.47 x 6.02 x 0.13	30.4 (2.8)	20.3 (2.4)	220 (100)	2/75	4"-12"	820	820	1145
20x400	Sing/Ft	1'7" x 21'1" x 5"	0.47 x 6.42 x 0.13	32.4 (3.0)	21.7 (2.6)	235 (107)	2/80	4"-12"	875	875	1215
20x425	Sing/Ft	1'7" x 22'5" x 5"	0.47 x 6.82 x 0.13	34.4 (3.2)	23.0 (2.7)	250 (114)	2/85	4"-12"	925	925	1290
20x450	Sing/Ft	1'7" x 23'8" x 5"	0.47 x 7.21 x 0.13	36.4 (3.4)	24.4 (2.9)	265 (121)	2/90	4"-12"	975	975	1360
20x475	Sing/Ft	1'7" x 25'0" x 5"	0.47 x 7.61 x 0.13	38.4 (3.6)	25.7 (3.0)	280 (128)	2/95	4"-12"	1025	1025	1435
20x500	Sing/Ft	1'7" x 26'3" x 5"	0.47 x 8.01 x 0.13	40.4 (3.8)	27.1 (3.2)	295 (134)	2/100	4"-12"	1080	1080	1505
40x75	Sing/Ft	2'7" x 4'2" x 5"	0.79 x 1.27 x 0.13	10.7 (1.0)	8.2 (0.8)	80 (37)	5/15	4"-24"	270	270	395
40x100	Sing/Ft	2'7" x 5'6" x 5"	0.79 x 1.67 x 0.13	14.1 (1.3)	10.9 (1.1)	105 (48)	5/20	4"-24"	340	340	515
40x125	Sing/Ft	2'7" x 6'9" x 5"	0.79 x 2.06 x 0.13	17.4 (1.6)	13.6 (1.4)	130 (59)	5/25	4"-24"	415	415	630
40x150	Sing/Ft	2'7" x 8'1" x 5"	0.79 x 2.46 x 0.13	20.8 (1.9)	16.3 (1.7)	150 (69)	5/30	4"-24"	485	485	745
40x175	Sing/Ft	2'7" x 9'5" x 5"	0.79 x 2.85 x 0.13	24.1 (2.3)	19.0 (2.0)	175 (80)	5/35	4"-24"	560	560	860
40x200	Sing/Ft	2'7" x 10'8" x 5"	0.79 x 3.25 x 0.13	27.5 (2.6)	21.7 (2.2)	200 (91)	5/40	4"-24"	635	635	975
40x225	Sing/Ft	2'7" x 12'0" x 5"	0.79 x 3.65 x 0.13	30.8 (2.9)	24.4 (2.5)	225 (103)	5/45	4"-24"	705	705	1090
40x250	Sing/Ft	2'7" x 13'3" x 5"	0.79 x 4.04 x 0.13	34.2 (3.2)	27.1 (2.8)	250 (114)	5/50	4"-24"	780	780	1205
40x275	Sing/Ft	2'7" x 14'7" x 5"	0.79 x 4.44 x 0.13	37.5 (3.5)	29.8 (3.1)	275 (125)	5/55	4"-24"	850	850	1325
40x300	Sing/Ft	2'7" x 15'11" x 5"	0.79 x 4.84 x 0.13	40.9 (3.8)	32.5 (3.4)	295 (134)	5/60	4"-24"	925	925	1440
40x325	Sing/Ft	2'7" x 17'2" x 5"	0.79 x 5.23 x 0.13	44.2 (4.1)	35.2 (3.6)	320 (146)	5/65	4"-24"	995	995	1555
40x350	Sing/Ft	2'7" x 18'6" x 5"	0.79 x 5.63 x 0.13	47.6 (4.4)	37.9 (3.9)	345 (157)	5/70	4"-24"	1070	1070	1670
40x375	Sing/Ft	2'7" x 19'9" x 5"	0.79 x 6.02 x 0.13	51.0 (4.8)	40.6 (4.2)	370 (168)	5/75	4"-24"	1145	1145	1785
40x400	Sing/Ft	2'7" x 21'1" x 5"	0.79 x 6.42 x 0.13	54.3 (5.1)	43.3 (4.5)	395 (180)	5/80	4"-24"	1215	1215	1900
40x425	Sing/Ft	2'7" x 22'5" x 5"	0.79 x 6.82 x 0.13	57.7 (5.4)	46.0 (4.8)	420 (191)	5/85	4"-24"	1290	1290	2015
40x450	Sing/Ft	2'7" x 23'8" x 5"	0.79 x 7.21 x 0.13	61.0 (5.7)	48.7 (5.0)	440 (200)	5/90	4"-24"	1360	1360	2135
40x475	Sing/Ft	2'7" x 25'0" x 5"	0.79 x 7.61 x 0.13	64.4 (6.0)	51.4 (5.3)	465 (211)	5/95	4"-24"	1435	1435	2250
40x500	Sing/Ft	2'7" x 26'3" x 5"	0.79 x 8.01 x 0.13	67.7 (6.3)	54.1 (5.6)	490 (223)	5/100	4"-24"	1505	1505	2365
60x75	Sing/Ft	3'8" x 4'2" x 5"	1.11 x 1.27 x 0.13	15.0 (1.4)	12.2 (1.2)	110 (50)	7/15	4"-37"	335	335	525
60x100	Sing/Ft	3'8" x 5'6" x 5"	1.11 x 1.67 x 0.13	19.7 (1.9)	16.3 (1.6)	145 (66)	7/20	4"-37"	425	425	685
60x125	Sing/Ft	3'8" x 6'9" x 5"	1.11 x 2.06 x 0.13	24.4 (2.3)	20.3 (2.0)	180 (82)	7/25	4"-37"	520	520	845
60x150	Sing/Ft	3'8" x 8'1" x 5"	1.11 x 2.46 x 0.13	29.1 (2.7)	24.4 (2.4)	210 (96)	7/30	4"-37"	615	615	1000
60x175	Sing/Ft	3'8" x 9'5" x 5"	1.11 x 2.85 x 0.13	33.8 (3.2)	28.4 (2.8)	245 (112)	7/35	4"-37"	710	710	1160
60x200	Sing/Ft	3'8" x 10'8" x 5"	1.11 x 3.25 x 0.13	38.6 (3.6)	32.5 (3.2)	280 (128)	7/40	4"-37"	805	805	1320
60x225	Sing/Ft	3'8" x 12'0" x 5"	1.11 x 3.65 x 0.13	43.3 (4.1)	36.6 (3.6)	315 (143)	7/45	4"-37"	900	900	1475
60x250	Sing/Ft	3'8" x 13'3" x 5"	1.11 x 4.04 x 0.13	48.0 (4.5)	40.6 (4.0)	350 (159)	7/50	4"-37"	995	995	1635
60x275	Sing/Ft	3'8" x 14'7" x 5"	1.11 x 4.44 x 0.13	52.7 (4.9)	44.7 (4.4)	380 (173)	7/55	4"-37"	1085	1085	1795
60x300	Sing/Ft	3'8" x 15'11" x 5"	1.11 x 4.84 x 0.13	57.4 (5.4)	48.7 (4.8)	415 (189)	7/60	4"-37"	1180	1180	1955
60x325	Sing/Ft	3'8" x 17'2" x 5"	1.11 x 5.23 x 0.13	62.1 (5.8)	52.8 (5.2)	450 (205)	7/65	4"-37"	1275	1275	2110
60x350	Sing/Ft	3'8" x 18'6" x 5"	1.11 x 5.63 x 0.13	66.8 (6.2)	56.8 (5.6)	485 (220)	7/70	4"-37"	1370	1370	2270
60x375	Sing/Ft	3'8" x 19'9" x 5"	1.11 x 6.02 x 0.13	71.5 (6.7)	60.9 (6.0)	515 (234)	7/75	4"-37"	1465	1465	2430
60x400	Sing/Ft	3'8" x 21'1" x 5"	1.11 x 6.42 x 0.13	76.2 (7.1)	64.9 (6.4)	550 (250)	7/80	4"-37"	1560	1560	2585
60x425	Sing/Ft	3'8" x 22'5" x 5"	1.11 x 6.82 x 0.13	80.9 (7.6)	69.0 (6.8)	585 (266)	7/85	4"-37"	1655	1655	2745
60x450	Sing/Ft	3'8" x 23'8" x 5"	1.11 x 7.21 x 0.13	85.6 (8.0)	73.1 (7.2)	620 (282)	7/90	4"-37"	1745	1745	2905
60x475	Sing/Ft	3'8" x 25'0" x 5"	1.11 x 7.61 x 0.13	90.3 (8.4)	77.1 (7.6)	655 (298)	7/95	4"-37"	1840	1840	3065
60x500	Sing/Ft	3'8" x 26'3" x 5"	1.11 x 8.01 x 0.13	95.0 (8.9)	81.2 (8.0)	685 (311)	7/100	4"-37"	1935	1935	3220
80x75	Sing/Ft	4'8" x 4'2" x 5"	1.43 x 1.27 x 0.13	19.3 (1.8)	16.3 (1.6)	140 (64)	10/15	4"-49"	485	485	745
80x100	Sing/Ft	4'8" x 5'6" x 5"	1.43 x 1.67 x 0.13	25.4 (2.4)	21.7 (2.1)	185 (84)	10/20	4"-49"	635	635	975
80x125	Sing/Ft	4'8" x 6'9" x 5"	1.43 x 2.06 x 0.13	31.5 (2.9)	27.1 (2.6)	230 (105)	10/25	4"-49"	780	780	1205
80x150	Sing/Ft	4'8" x 8'1" x 5"	1.43 x 2.46 x 0.13	37.5 (3.5)	32.5 (3.1)	275 (125)	10/30	4"-49"	925	925	1440
80x175	Sing/Ft	4'8" x 9'5" x 5"	1.43 x 2.85 x 0.13	43.6 (4.1)	37.9 (3.6)	315 (143)	10/35	4"-49"	1070	1070	1670
80x200	Sing/Ft	4'8" x 10'8" x 5"	1.43 x 3.25 x 0.13	49.6 (4.6)	43.3 (4.2)	360 (164)	10/40	4"-49"	1215	1215	1900
80x225	Sing/Ft	4'8" x 12'0" x 5"	1.43 x 3.65 x 0.13	55.7 (5.2)	48.7 (4.7)	405 (184)	10/45	4"-49"	1360	1360	2135
80x250	Sing/Ft	4'8" x 13'3" x 5"	1.43 x 4.04 x 0.13	61.7 (5.8)	54.1 (5.2)	445 (202)	10/50	4"-49"	1505	1505	2365
80x275	Sing/Ft	4'8" x 14'7" x 5"	1.43 x 4.44 x 0.13	67.8 (6.3)	59.5 (5.7)	490 (223)	10/55	4"-49"	1655	1655	2595
80x300	Sing/Ft	4'8" x 15'11" x 5"	1.43 x 4.84 x 0.13	73.9 (6.9)	64.9 (6.2)	535 (243)	10/60	4"-49"	1800	1800	2825
80x325	Sing/Ft	4'8" x 17'2" x 5"	1.43 x 5.23 x 0.13	79.9 (7.5)	70.4 (6.8)	580 (264)	10/65	4"-49"	1945	1945	3060
80x350	Sing/Ft	4'8" x 18'6" x 5"	1.43 x 5.63 x 0.13	86.0 (8.1)	75.8 (7.3)	620 (282)	10/70	4"-49"	2090	2090	3290
80x375	Sing/Ft	4'8" x 19'9" x 5"	1.43 x 6.02 x 0.13	92.0 (8.6)	81.2 (7.8)	665 (302)	10/75	4"-49"	2235	2235	3520
80x400	Sing/Ft	4'8" x 21'1" x 5"	1.43 x 6.42 x 0.13	98.1 (9.2)	86.6 (8.3)	710 (323)	10/80	4"-49"	2380	2380	3755

THIS DRAWING REPRESENTS DESIGN INTENT ONLY. FABRICATOR WILL BE RESPONSIBLE TO VERIFY ALL CONDITIONS IN FIELD PRIOR TO SHOP DRAWINGS. REFER TO SIGN LOCATION PLAN AND MESSAGE SCHEDULE FOR SIGN TYPES AND LOCATIONS.

Client/Project Western Michigan University Signage Bid Document		Project No. 14WMU249001
Date 12.12.16	Revisions	Scale As noted

PIXELS HIGH (AAA)	PIXELS WIDE (BBB)	PIXEL SPACING (CC)
40	100	15.85mm
32	80	19.81mm
24	60	26.42mm

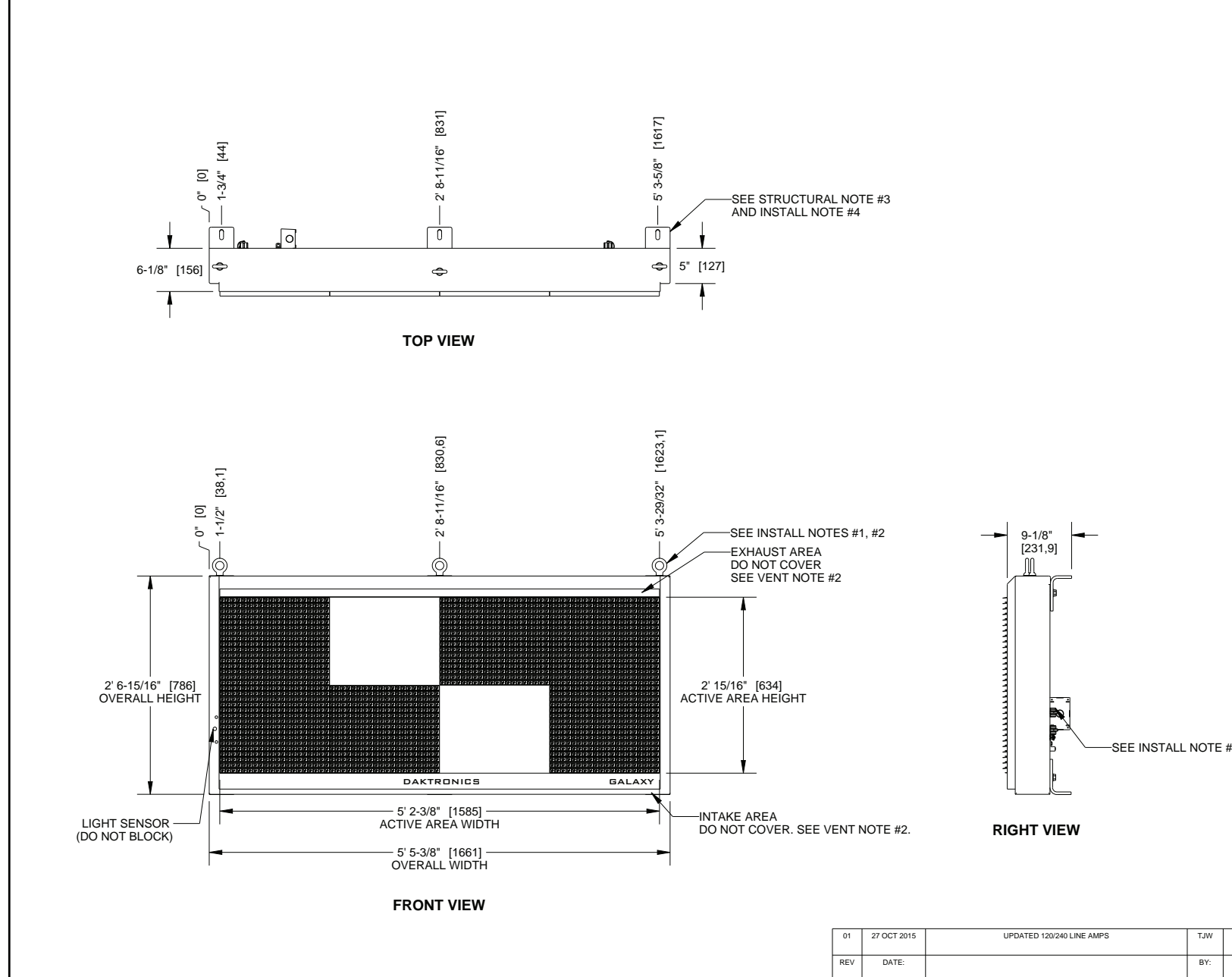

#	DETAIL	DESCRIPTION
1	DISPLAY	GS6 - AAAxBBB-CC (SEE CHART ON TOP LEFT)
2	LED COLOR	RED, AMBER, OR RGB
3	ACTIVE AREA	2' 15/16" [634] X 5' 2-3/8" [1585]
4	OVERALL SIZE	2' 6-15/16" [786] X 5' 5-3/8" [1661]
5	CABINET	ALUMINUM & STEEL
6	VENTILATION	FRONT
7	ACCESS	SERVICE FROM FRONT OF DISPLAY
8	WEIGHT	102 LBS [47 KG] (APPROX)
9	SHIPPING	SHIPPED AS A SINGLE UNIT
10	DIMENSIONS	FEET AND INCHES [MILLIMETERS]
11	PAINTED	SEMI-GLOSS BLACK

STRUCTURAL RATING

1	DESIGN WIND PRESSURE "P" (CASE A)	P _{cs} =100 PSF (ASD)
2	STANDARD/CODE	IBC 2009/ASCE7-05, IBC 2012/ASCE7-10
3	ALL CLIP ANGLES MUST BE USED TO MOUNT DISPLAY	

POWER RATING PER SINGLE FACE: FOR SIZING ELEC.SERVICE MAX REQ'D SHOWN

TECHNOLOGY	COLOR	MAX WATTS	120/240VAC 1PH 60Hz (3 WIRES + GND) DOMESTIC		240VAC 1PH 50Hz (2 WIRES + GND) INTERNATIONAL SPECIAL ORDER
			LINE 1 AMPS	LINE 2 AMPS	LINE 1 (AMPS)
GS6	RED	340	2.84	N/A	1.42
	AMBER	340	2.84	N/A	1.42
	RGB	511	4.26	N/A	2.13

VENTILATION REQUIREMENTS

1	DISPLAY RELIES ON VENTILATION TO FUNCTION PROPERLY. INTAKES, LOCATED AT THE FRONT OF THE DISPLAY, MUST BE ABLE TO DRAW IN AIR AT A TEMPERATURE NO GREATER THAN 120°F.
2	IN ORDER TO ENSURE AMBIENT TEMPERATURE AIRFLOW IS MAINTAINED, NO PORTION OF THE VENTILATION OPENINGS ALONG THE FRONT OF THE DISPLAY MAY BE COVERED OR OBSTRUCTED IN ANY WAY.

INSTALL NOTES

1	IN ORDER TO PRESERVE THE STRUCTURAL INTEGRITY OF THE DISPLAY CABINET, THE 90° ANGLE BETWEEN THE CABINET AND THE LIFTEYE MUST BE MAINTAINED - USING A SPREADER BEAM IS SUGGESTED. ALL EYEBOLTS MUST BE USED WHEN LIFTING.
2	1/2" LIFTEYES TO ASSIST WITH DISPLAY INSTALLATION. LIFTEYES MAY NOT BE USED FOR PERMANENT INSTALLATION. LIFTEYES MAY BE REMOVED.
3	MECHANICAL AND SIGNAL CONNECTIONS OCCUR EXTERNAL TO DISPLAY.
4	CLIP ANGLE FOR MOUNTING. CLIP ANGLES CAN BE ADJUSTED VERTICALLY 1 - 3/16" AS NEEDED DURING INSTALLATION. CLIP ANGLE CAN BE WELDED OR BOLTED TO STRINGER.
5	DAKTRONICS IS NOT RESPONSIBLE FOR THE MOUNTING HARDWARE OR THE INTEGRITY OF THE MOUNTING STRUCTURE.
6	DAKTRONICS IS NOT RESPONSIBLE FOR THE MAIN ELECTRICAL DISCONNECT. SEE POWER RATINGS ABOVE.
7	SEE DWG-03097583 FOR SIGNAL & MTG DETAILS

SUBMITTAL APPROVAL

APPROVED
 APPROVED AS NOTED
 APPROVED AS NOTED & RESUBMIT

COMPANY: _____
 SIGNED: _____
 TITLE: _____ DATE: _____

 DAKTRONICS, INC. BROOKINGS, SD 57006 <small>DO NOT SCALE DRAWING</small>	<small>THE CONCEPTS EXPRESSED AND DETAILS SHOWN ON THIS DRAWING ARE CONFIDENTIAL AND PROPRIETARY. DO NOT REPRODUCE BY ANY MEANS WITHOUT THE EXPRESS WRITTEN CONSENT OF DAKTRONICS, INC. COPYRIGHT 2015 DAKTRONICS, INC.</small>	
	PROJ: GALAXY GS6 SERIES TITLE: SHOP DWG, GS6-R, 2' 7"x5' 6" (2x4 MODS) DESIGN: TWHITEH DRAWN: DOSTRAA DATE: 26-OCT-15 SCALE: 1/15 SHEET: 1 OF 1 REV: 01 JOB NO: P 1817 FUNC-TYPE-SIZE: E - 07 - B	

01	27 OCT 2015	UPDATED 120/240 LINE AMPS	TJW
REV	DATE:		BY:

THIS DRAWING REPRESENTS DESIGN INTENT ONLY. FABRICATOR WILL BE RESPONSIBLE TO VERIFY ALL CONDITIONS IN FIELD PRIOR TO SHOP DRAWINGS. REFER TO SIGN LOCATION PLAN AND MESSAGE SCHEDULE FOR SIGN TYPES AND LOCATIONS.

Client/Project	Project No.
Western Michigan University Signage Bid Document	14WMU249001
Date	Revisions
12.12.16	As noted

CONTROL SOFTWARE



INTRODUCING THE NEW VENUS CONTROL SUITE

Operators at any level can access this software any time, anywhere, on any device.

It's easy to focus on just the hardware when you sell an LED sign. But sharing the software's selling points further convinces your customers to buy. The control solution we offer combines functionality with a great user experience that is innovative and yet easy to use.

CLOUD-BASED SOFTWARE ACCESS FROM ANY DEVICE

Venus® Control Suite is browser based, so users can access the software from any device with an Internet connection—smartphones, tablets, laptops, and desktops.

FLEXIBLE EXPERIENCE FITS ANY OPERATOR

Venus Control Suite adjusts to meet the needs of any level of user. From basic to advanced, this system works for everyone.

SECURE SOLUTION, WE TAKE CARE OF IT

Daktronics hosts the Venus Control Suite on our secure servers, so we take care of computer software and operating system compatibility. We also ensure that your customer always has access to the latest version.

FEATURES & BENEFITS:

- › Easily import graphics and organize files:
 - › Drag-and-drop content directly to media library.
 - › Use tagging to quickly manage media.
- › Choose simple to sophisticated scheduling and multiple playlists.
- › Secure hosted servers and communication eases IT needs.
- › Use the dashboard to see the status and content on your display.
- › Use from your smartphone—this software is mobile optimized.
- › Get the latest feature updates automatically.
- › Multiple authorized user access

CONTROL SOFTWARE

To help support your sale, we've put together a Venus® Control Suite web area and software videos. Use daktronics.com/venus when you call on your next customer.

EVEN BEFORE INSTALLATION, CUSTOMERS BEGIN CONTENT CREATION

As soon as we create your customers' account, they can access the software and start creating content. Using the free, professionally created content that comes with the display will speed up and enhance their ad campaigns.

VENUS® LEARNING CENTER

Offer your customers self-guided training to successfully set up and operate Venus Control Suite software at daktronics.com/venuslearning

FREE VIDEO TUTORIALS

Daktronics provides your customers with a set of free tutorials. They're a great way to learn the software or to use as a refresher course. Each video tutorial demonstrates how to perform a specific task in the software. Learn how to configure displays, create memorable presentations, schedule playlists, and more. Find the complete set of tutorials at daktronics.com/venuslearning

YOUR CUSTOMERS WANT MORE?

We tailor Venus Control Suite for your customers' needs. To do this we have different packages available to choose from. All of the features explained are part of the Prime software package, which comes with each display purchase. If your customers are interested in more, they can upgrade to the Pro package, which adds features such as:

External Data Feeds

Pull in real time information, such as weather forecasts, news, headlines, and sports scores from any Internet provided data source and display it on your LED message center.

Reporting (proof of play)

Access reports showing what played on your display, how many times, and when. Compare the report to your sales numbers and promote product lift. For more details on packages, talk to your local sales representative.

IMPORTABLE FILE TYPES

Video file types	.avi, .mpg, .mp4, .mov
Image file types	.png, .bmp, .gif, .jpg, .tif, .tiff, .psd
Data feed types	Time, Temp, RSS*, Atom*, .XML*

*Only on data capable displays.

SUPPORTED MOBILE BROWSERS

- iOS Safari®
- Android® Chrome®

SUPPORTED DESKTOP BROWSERS

- Microsoft® Internet Explorer® v11 and newer
- Microsoft® Edge®
- Google® Chrome®
- Mozilla Firefox®

24 RETURN TO TABLE OF CONTENTS
RETURN TO TABLE OF CONTENTS 25

THIS DRAWING REPRESENTS DESIGN INTENT ONLY. FABRICATOR WILL BE RESPONSIBLE TO VERIFY ALL CONDITIONS IN FIELD PRIOR TO SHOP DRAWINGS. REFER TO SIGN LOCATION PLAN AND MESSAGE SCHEDULE FOR SIGN TYPES AND LOCATIONS.

Client/Project Western Michigan University Signage Bid Document		Project No. 14WMU249001
Date 12.12.16	Revisions	Scale As noted

COMMUNICATION OPTIONS



GALAXY® GS6 COMMUNICATION

Ethernet network is necessary for GS6 displays.

The Galaxy® GS6 displays need an Internet connection to reach out to the cloud based Venus control system for content and schedule updates. Daktronics offers several Ethernet based communication options that can be added to a customer's local area network for Internet access.

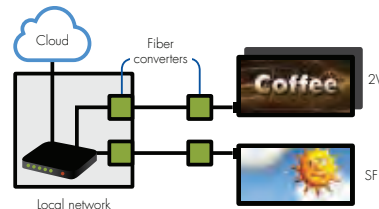

ETHERNET FIBER OPTIC

Fiber Optic is the most reliable communication option offered. Electrically isolated fiber optics prevent damage due to electromagnetic interference from lightning or electrical storms.

- Distance from the Ethernet network router to the display must be less than 6,547 ft (2,000 m).
- This option requires fiber-optic signal converters and 62.5µm multi-mode fiber-optic cables.

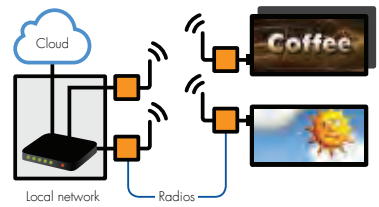

ETHERNET BRIDGE RADIO

Provides a wireless connection to Local Area Network on site.

- Use this option when fiber Ethernet cannot be pulled and the distance from the Ethernet network router to the display is less than 1,500 ft (450 m).
- This option requires outdoor installation for direct line of sight between server radio at the building and client radio at the display.
- This option is not recommended where significant RF interference exists (RF interference could be caused by cellular towers, radio/TV stations, wireless headsets, etc.).

Note: Wireless communication devices may be affected by site-specific conditions. Daktronics does not guarantee that wireless communication is suitable for every location.

COMMUNICATION OPTIONS

Fiber optic is the fastest, most reliable communication option available.

ETHERNET CAT5

- Use when fiber Ethernet cannot be pulled and the distance from the Ethernet network router to the display is less than 250 ft (76.2 m).
- This option requires direct CAT5 wire.

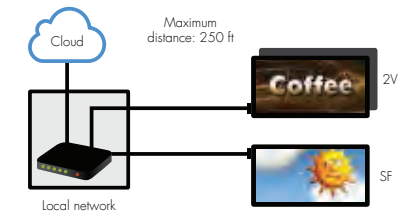

ETHERNET SWITCH

- Use when multiple displays are on a single Ethernet connection from the above options.
- Displays must be within 25 ft.
- This requires each display to have different IP addresses.

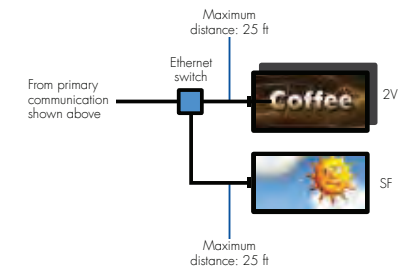

REMOTE CELLULAR

Provides an Internet connection without a Local Network.

- Avoid customer's network by having the display connect directly via cellular.
- Use when there is not a Local Area Network or Internet connection available on site.

Note: Each display must be located in a reliable cellular signal area. This connection does require a cellular service.

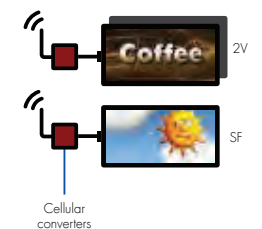

PERFORMANCE TRAITS	ETHERNET FIBER OPTIC	ETHERNET BRIDGE RADIO	ETHERNET CAT5	REMOTE CELLULAR
Max. distance from local network router to display	1.2 miles	1,500 feet	250 feet	unlimited
Reliability	best	good	good	good
Noise immunity	best	good	good	good
Data speed	best	good	best	good

THIS DRAWING REPRESENTS DESIGN INTENT ONLY. FABRICATOR WILL BE RESPONSIBLE TO VERIFY ALL CONDITIONS IN FIELD PRIOR TO SHOP DRAWINGS. REFER TO SIGN LOCATION PLAN AND MESSAGE SCHEDULE FOR SIGN TYPES AND LOCATIONS.

Client/Project Western Michigan University Signage Bid Document	Project No. 14WMU249001
Date 12.12.16	Revisions
Scale As noted	

GALAXY GS6 PRODUCT DESIGN



GALAXY GS6 FEATURES

This is the best full-feature, high-quality Galaxy series yet – Galaxy GS6. This product provides users a display that runs outstanding graphics and animations using the best contrast in the industry. As for the control software, we've developed the most convenient user experience to date.

SIGNAL REDUNDANCY
Image data is sent to individual LED modules from multiple directions. If a signal path fails, the module continues to operate from the additional signal.



FRONT VENTILATION
The installer doesn't need to deal with special ventilation requirements. It's built in with displays up to 7 feet tall.



HIGHER RESOLUTION
A true 15.85 millimeter pixel spacing allows more pixels per module resulting in higher resolution.



ALL SEALED COMPONENTS
Modules, power supplies, controller, power term panel, fan, and all connections fully sealed.



QUICK CONNECTIONS
Offer plug-and-play capability. Along with an external junction box for easy power connection.



SINGLE-STEP MODULE REMOVAL
A single turn of the wrench removes the multi-point attached module.



MOUNTING CLIPS
Slotted clip angles and multiple locations allows flexibility in mounting.



GALAXY GS6 PRODUCT DESIGN

IMPROVED, CLEAN CABINET APPEARANCE

- ▶ Narrow cabinet borders.
- ▶ Shallow 5-inch cabinet depth on displays up to 7 feet tall.



FEATURE SET

- ▶ All sealed components
- ▶ Quick connects
- ▶ Mounting clips
- ▶ High contrast louvers
- ▶ Redundant module signal
- ▶ Large sections for fast installation
- ▶ Front ventilation on displays less than seven feet tall
- ▶ No spreader beam required for displays greater than seven feet tall
- ▶ Same module size and cabinet size for all pixel pitches

SERIES TECHNICAL SPECIFICATIONS

Estimated LED Lifetime	100,000+ hours
Contrast Enhancement	Non-reflective black louvers and module face grooves disperse light
Message Capability	Text, graphics, logos, basic animation, video clips, data integration, multiple font styles, and sizes
Control Software	Venus® Control Suite
Power	120, 120/240 VAC single phase
Display Dimming	64 levels (automatic, scheduled or manual control)
Communication Options	Ethernet Fiber Optic, Ethernet Bridge Radio, Remote Cellular, Ethernet CAT5
Operating Temperature	-40°F to 120°F with 99% RH non-condensing
Compliance Information	UL and cUL Listed, UL-Energy Verified, FCC compliance
Warranty Coverage	5 Years
Product Support	Parts support for 10 years, see page 6 for details

28 RETURN TO TABLE OF CONTENTS

RETURN TO TABLE OF CONTENTS 29



THE DISTRICT
Sioux Falls, South Dakota
70 lines x 98 columns 26 mm RGB
Previous series shown

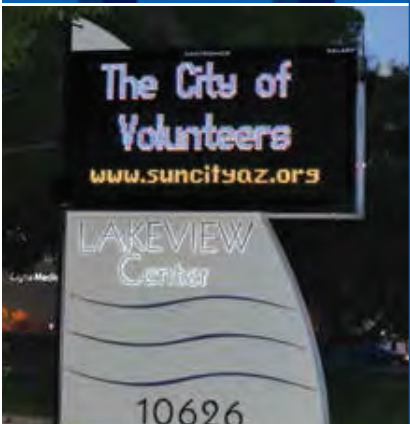

Lakeview Center
Sun City, Arizona
64 lines x 128 columns 16 mm RGB
Previous series shown

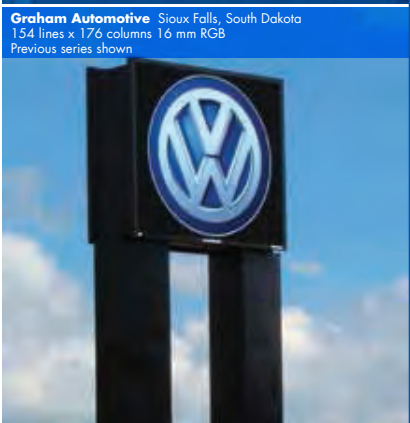

Graham Automotive
Sioux Falls, South Dakota
154 lines x 176 columns 16 mm RGB
Previous series shown

THIS DRAWING REPRESENTS DESIGN INTENT ONLY. FABRICATOR WILL BE RESPONSIBLE TO VERIFY ALL CONDITIONS IN FIELD PRIOR TO SHOP DRAWINGS. REFER TO SIGN LOCATION PLAN AND MESSAGE SCHEDULE FOR SIGN TYPES AND LOCATIONS.

Client/Project Western Michigan University Signage Bid Document		Project No. 14WMU249001
Date 12.12.16	Revisions	Scale As noted

Campus Wayfinding- New Place Names (“Nomenclature”)

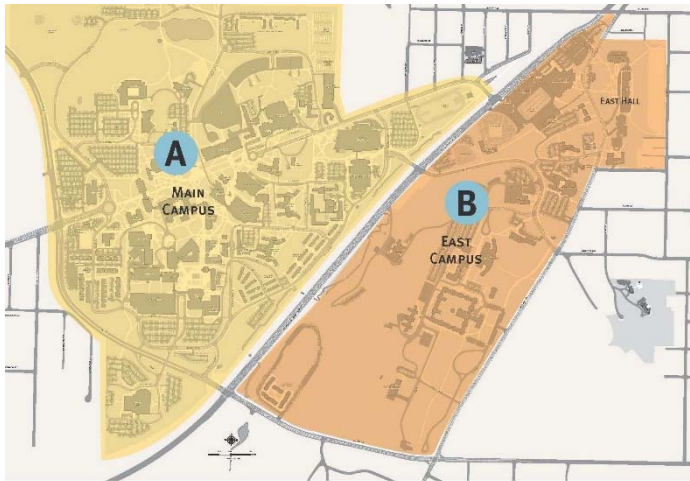

Campus Names

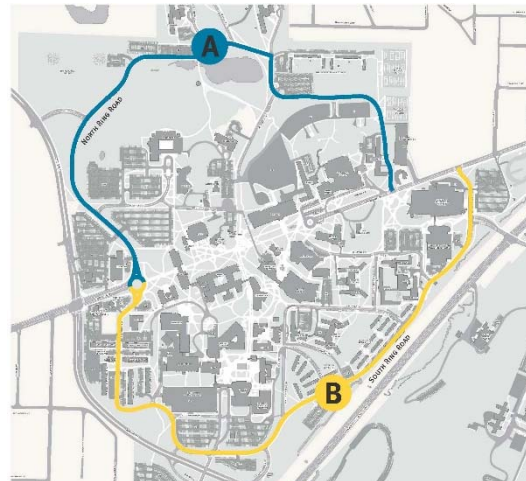

Ring Roads

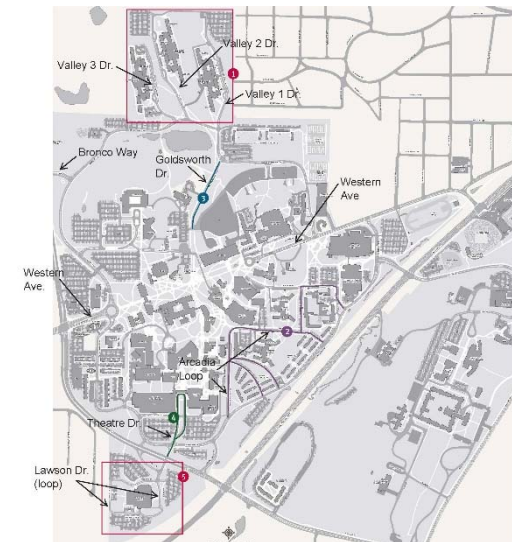

Street Names

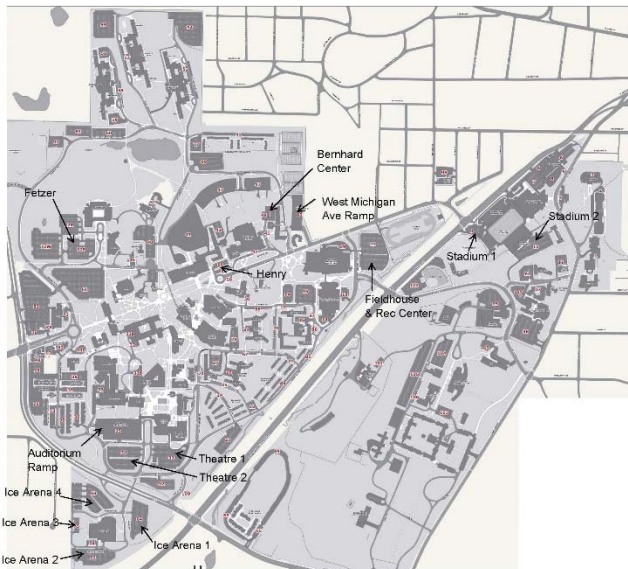

Visitor Parking

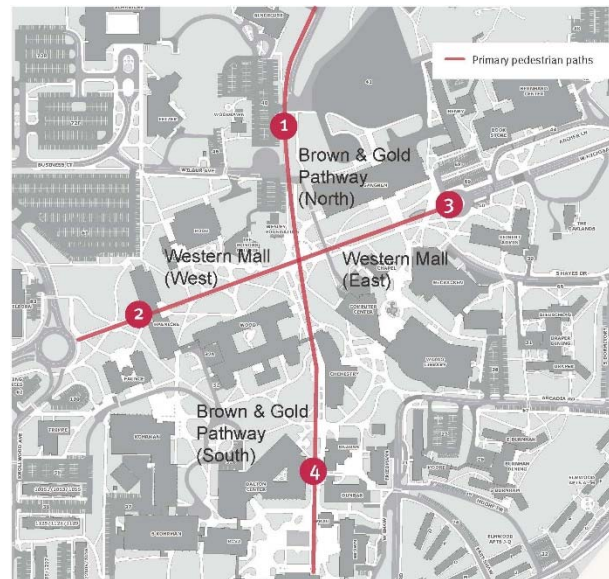

Main Pedestrian Pathways

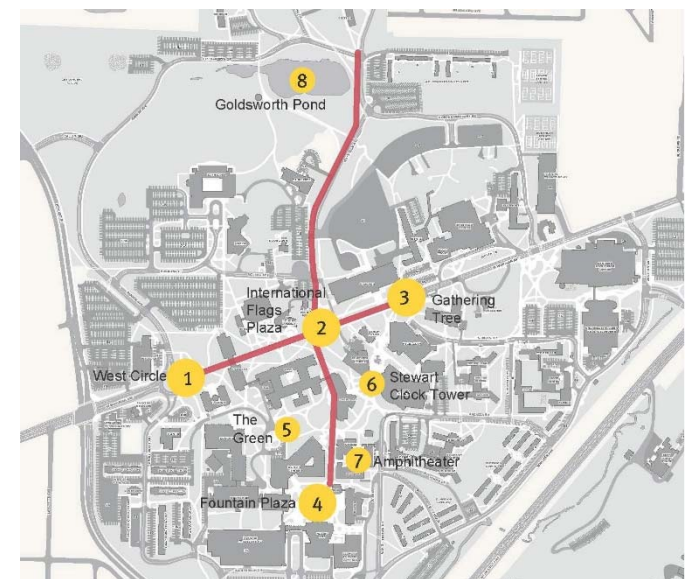

Landmarks